

NOTE:  
\* WOOD-DECK STUCTURE AND DESIGN IS THE RESPONSIBILITY OF THE OWNER.

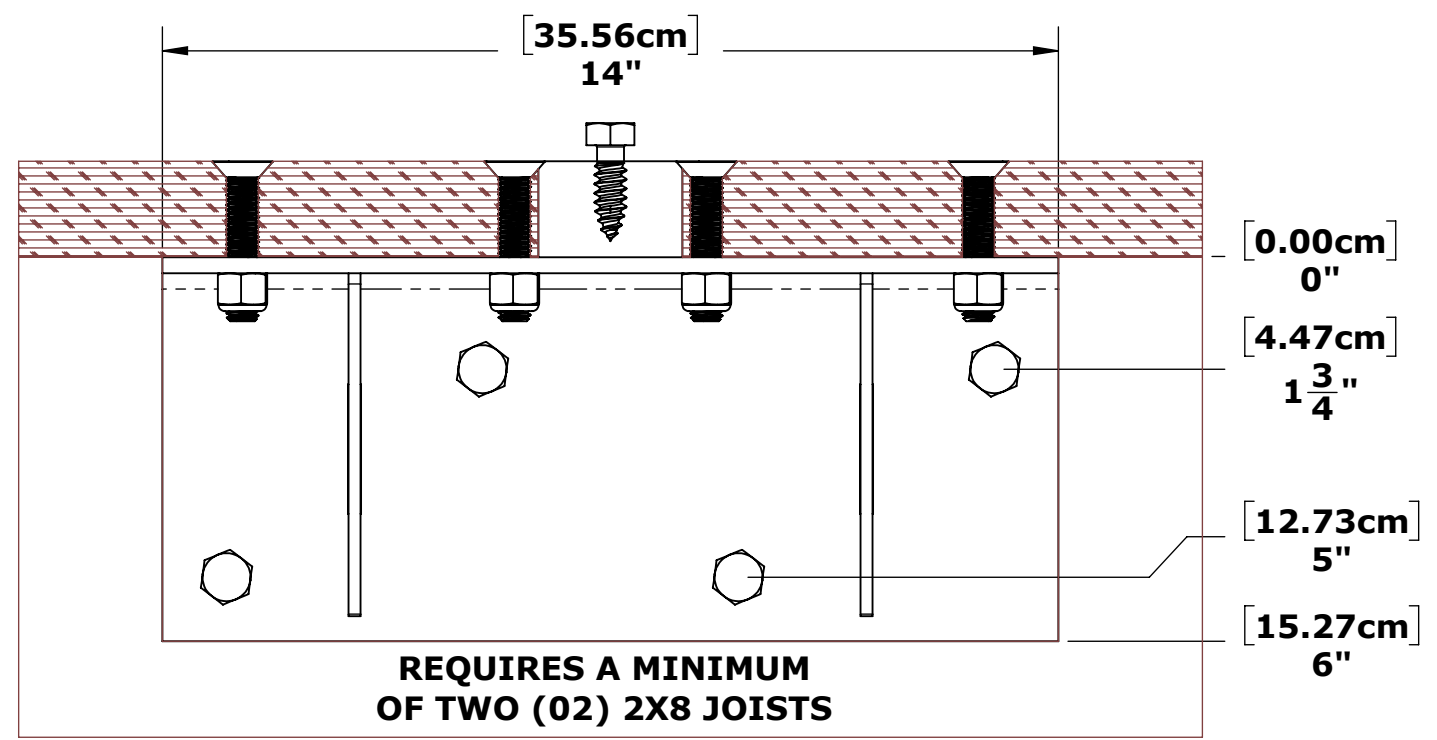
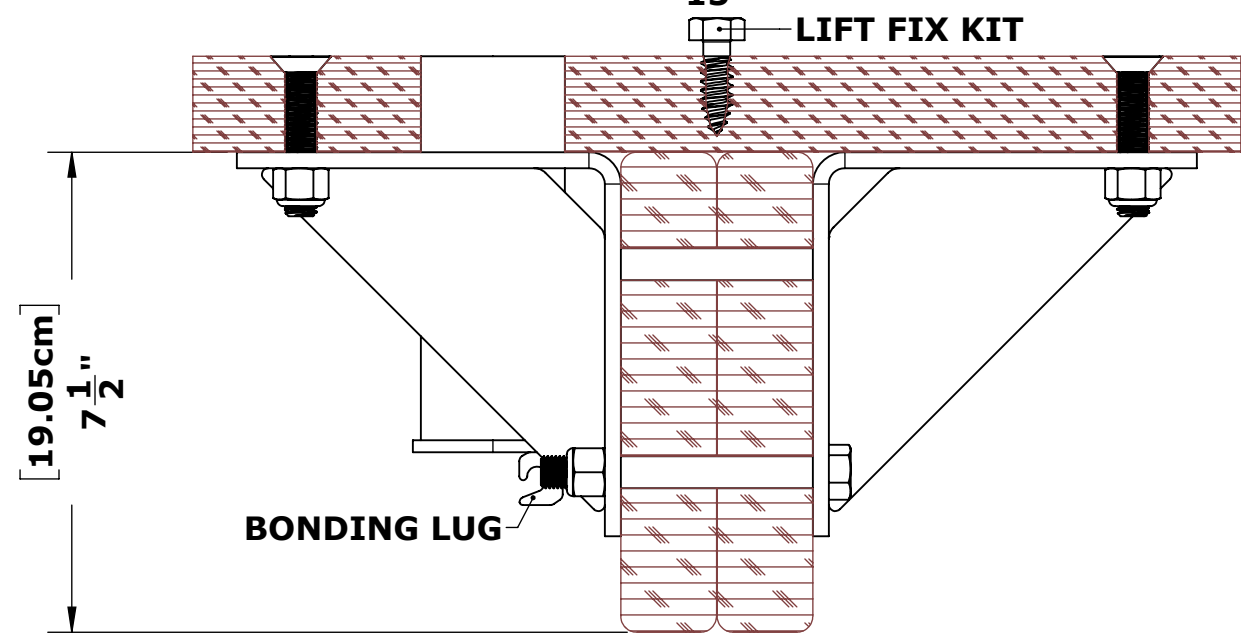
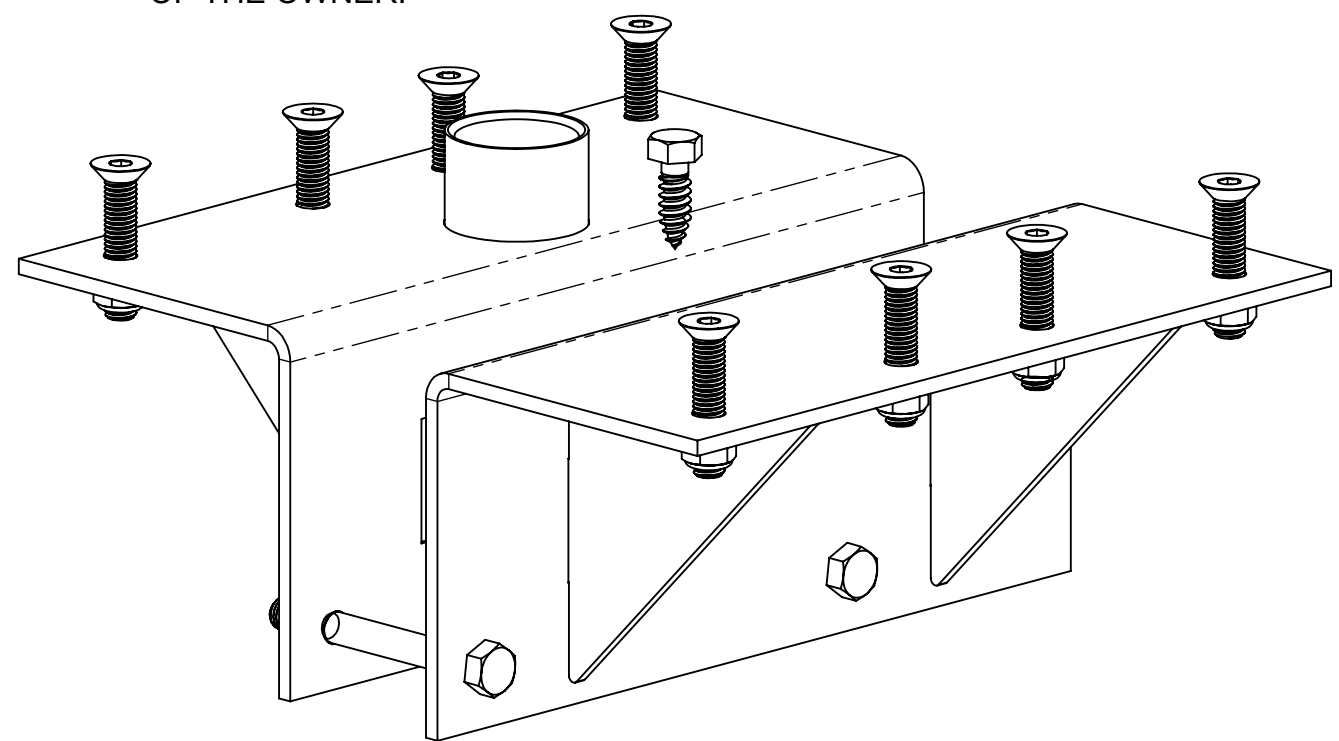
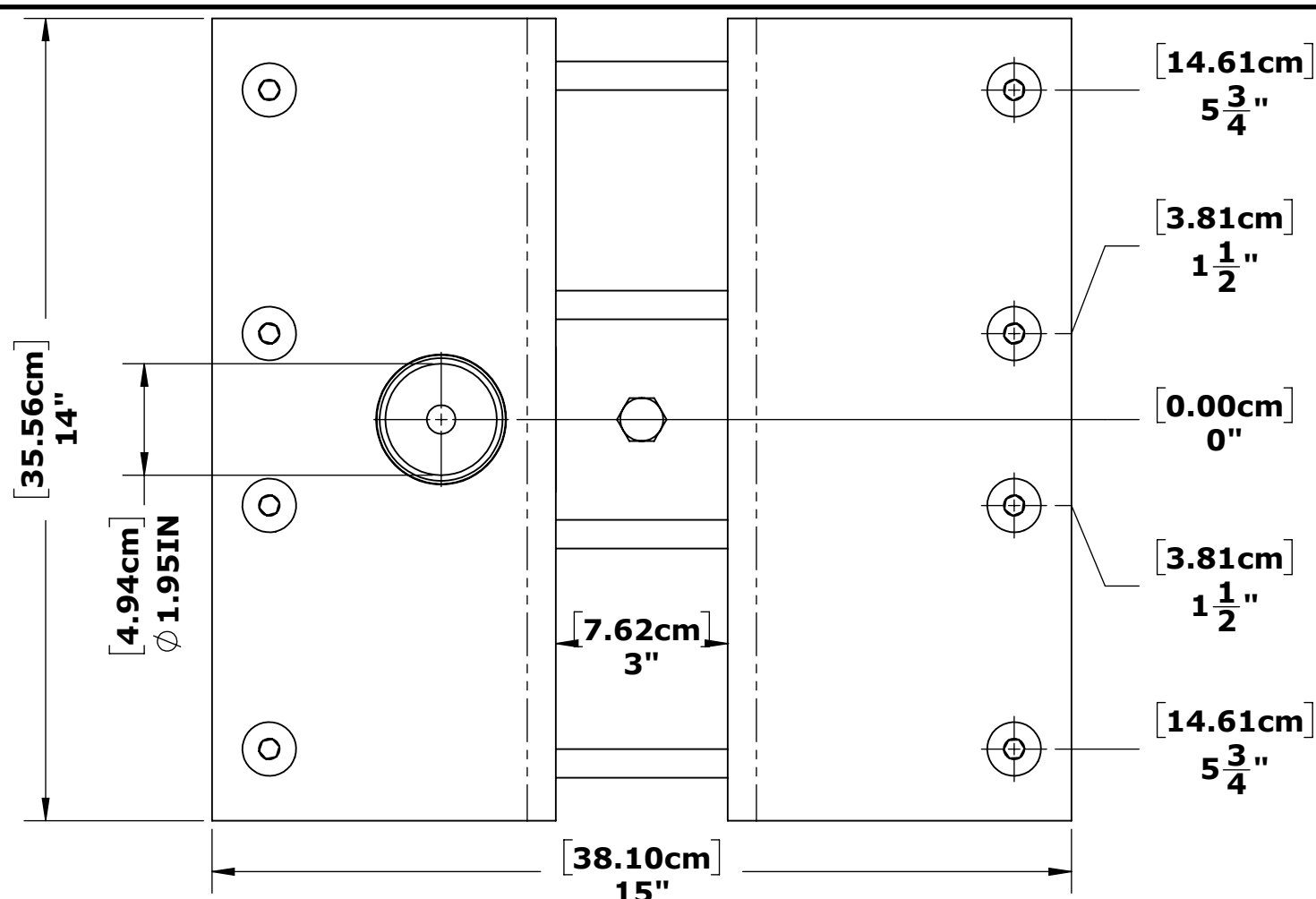

**REQUIRES A MINIMUM OF TWO (02) 2X8 JOISTS**

**ANCHOR - WOOD DECK - 1.90"X6.00"**  
**F-842SWDA**  
**PART NO. INV01504**

**TOLERANCES**  
DIMENSIONS ARE IN INCHES UNLESS OTHERWISE SHOWN  
FRACTIONAL: ..... ±1/16  
ANGULAR: ..... ±1°  
TWO PLACE DECIMAL: .... ±.01  
THREE PLACE DECIMAL: .. ±.005

**MATERIAL: 304 STAINLESS STEEL**  
**FINISH: POWDER COAT - WHITE**  
**APPROX. WEIGHT: 31.13 LBS.**



**9889 GARRYMORE LANE**  
**MISSOULA, MT 59808**  
**(406) 549-0769**  
**FAX (406) 549-2602**  
**www.AquaCreek.com**

**PROPRIETARY AND CONFIDENTIAL INFORMATION**  
THIS DRAWING AND ALL INFORMATION CONTAINED HEREIN IS THE SOLE PROPERTY OF AQUA CREEK PRODUCTS LLC. ANY REPRODUCTION IN PART OR AS A WHOLE WITHOUT WRITTEN PERMISSION FROM AQUA CREEK IS PROHIBITED.  
\*SPECIFICATIONS ARE SUBJECT TO CHANGE WITHOUT NOTICE

REVISIONS			
REV.	DESCRIPTION	DATE	APPROVED
P1	INITIAL RELEASE	6/3/2021	J.MAXWELL
P2	MODIFIED DESIGN - ECR-01504-P2	2/24/2022	J.MAXWELL