

8m/26' 3V Exact fit Platform plans

Disclaimer:

We have worked out detailed plans as a courtesy to our customers, to help them build exact fit platforms that optimally shed rain water and are easy to weather seal,

Please note that these plans are a complimentary gift, not a product we sell, It is up to each customer to ensure they satisfy local building codes and requirements, modifications and/or upgrades may be required depending on local codes, site specific details, slope, etc.

Our customers or their contractors may decide to make any type of modification to the plans they see fit.

We do not assume any liability for any issues arising from a platform build.

We also do not provide engineered anchoring solutions, only suggestions.

Please read the following document before planning your platform build for best practices.

Note on the runner design:

Our runner structure has less sides than the dome, which saves some material and cutting time, as well as deck blocks. This was a creative solution by our builder/designer, but not the only possible solution.

You may also decide to model your runner structure after the perimeter of the joist structure and use the same outer measurement and angles.

Please read through our illustrated platform guide before planning your build, as well as to get clarification on details that might be rather abstract in these plans.

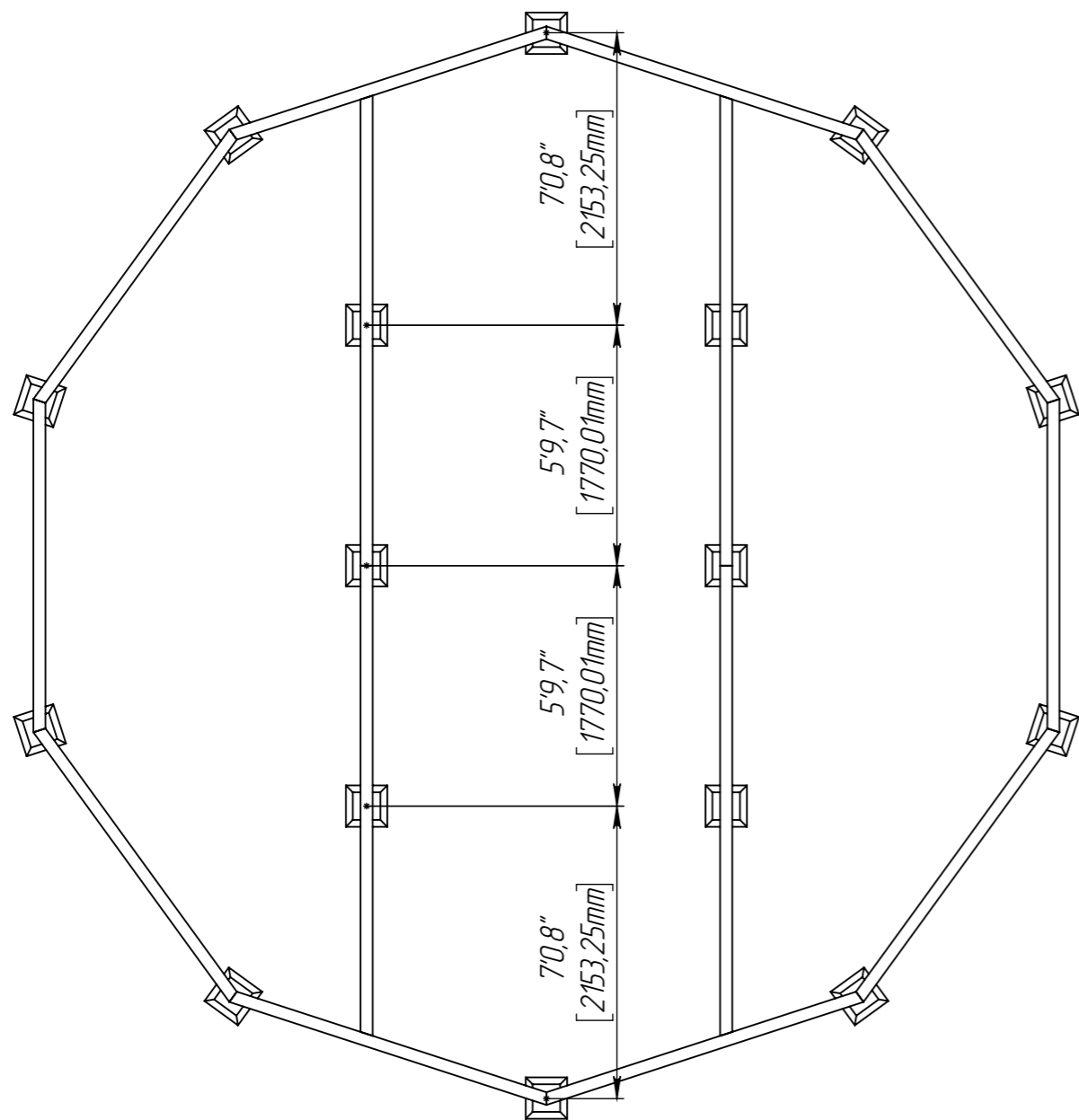
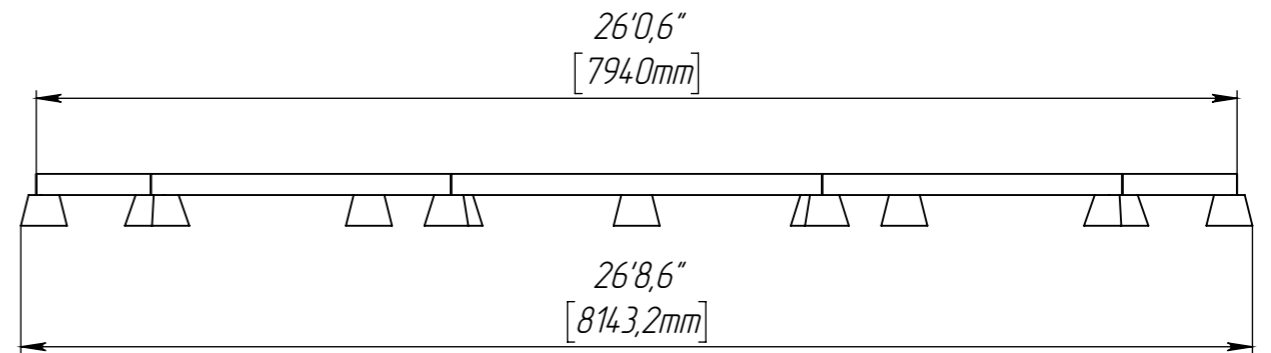
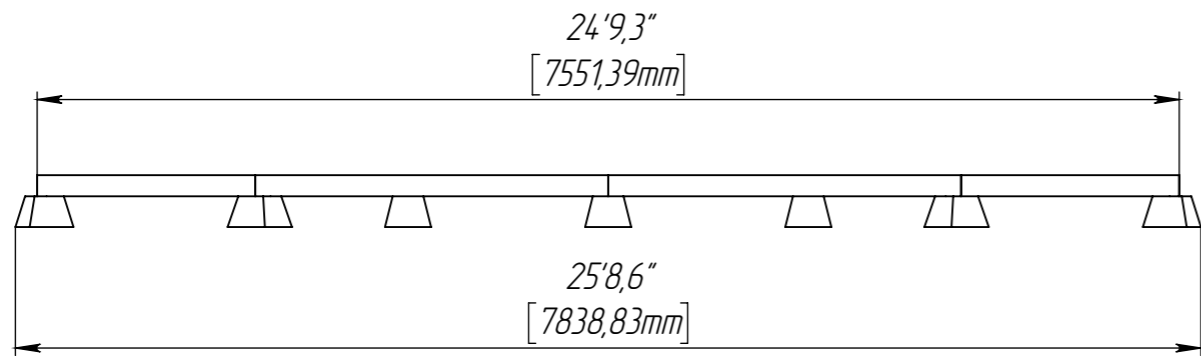

Pier Blocks layout and Runners

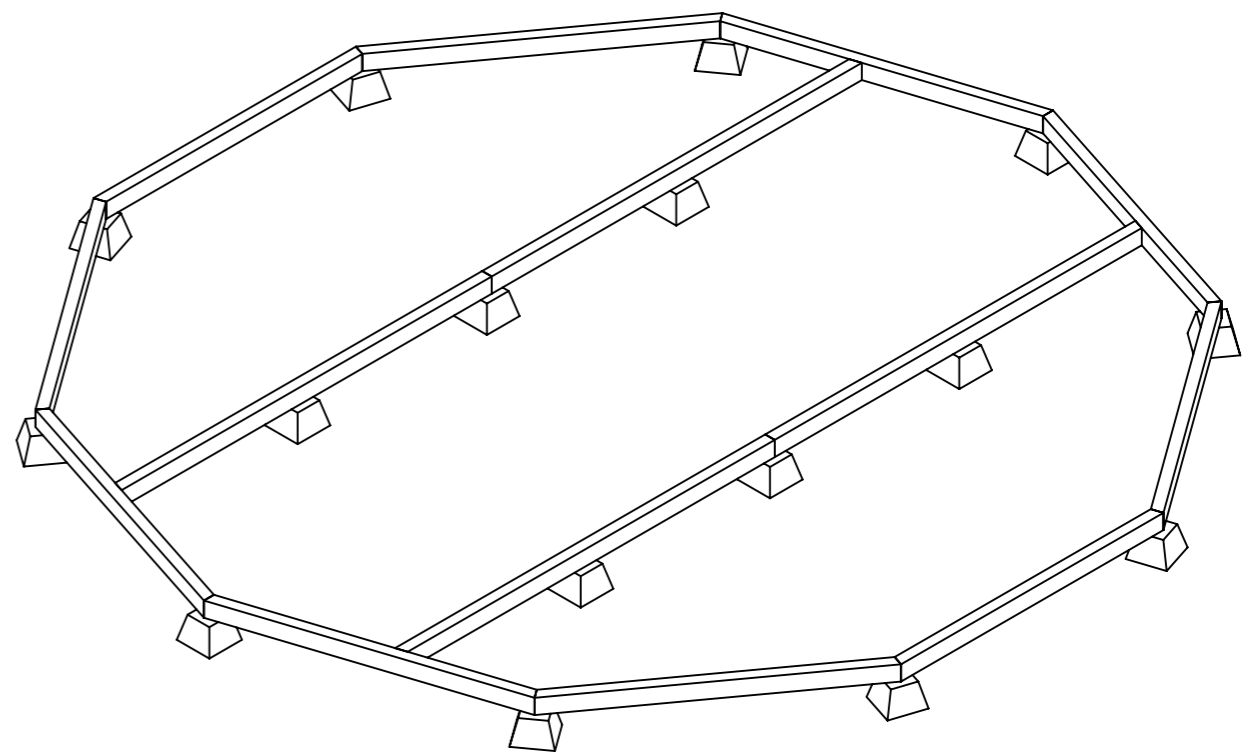

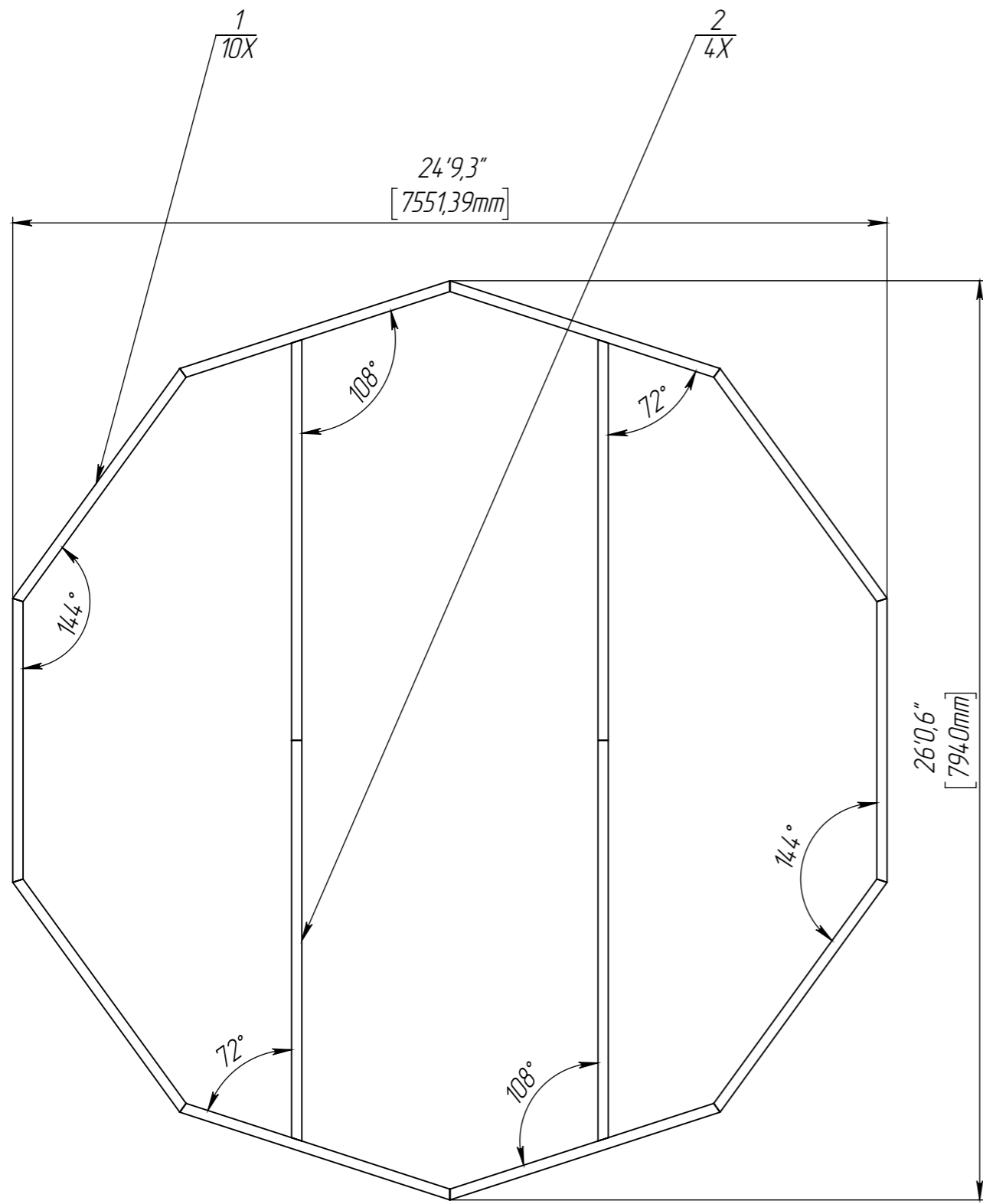

ITEM NO.	QTY.	Description	LENGTH	ANGLE1	ANGLE2	TOTAL LENGTH
1	10	Lumber 4x6	8'0.6"	18°	18°	125'11.0"
2	4	Lumber 4x6	11'4.3"	0°	18°	

Runner Diagram 4x6 Lumber

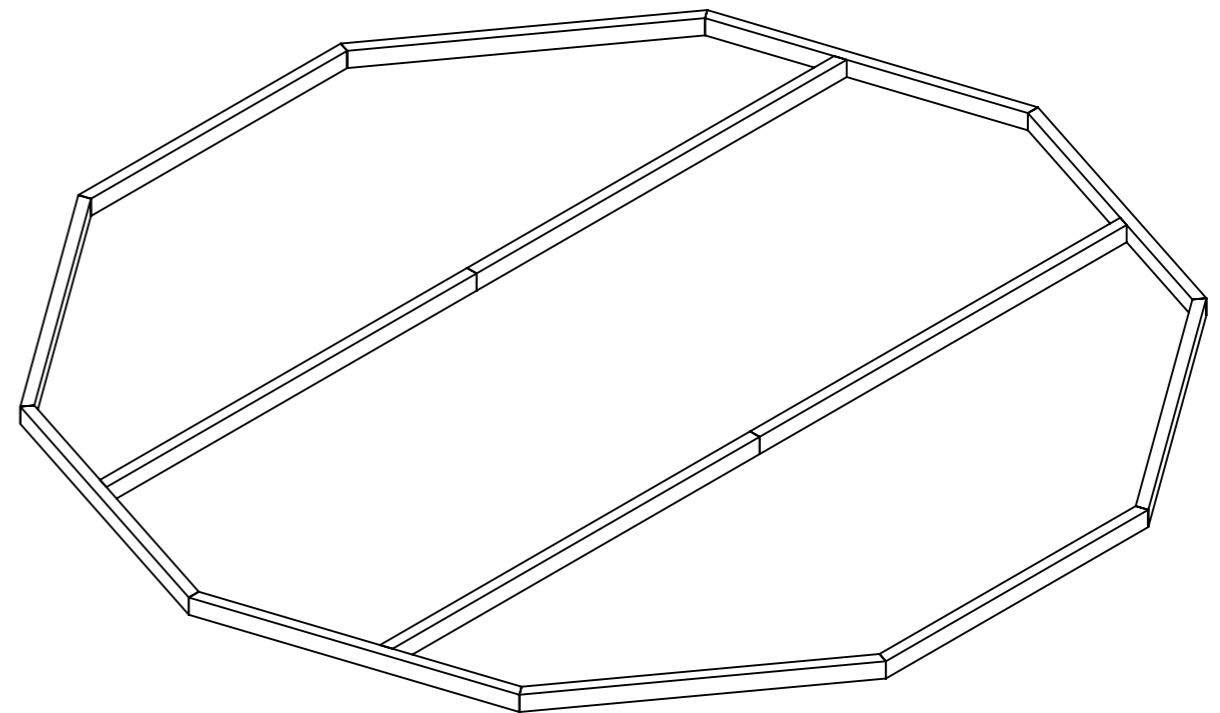

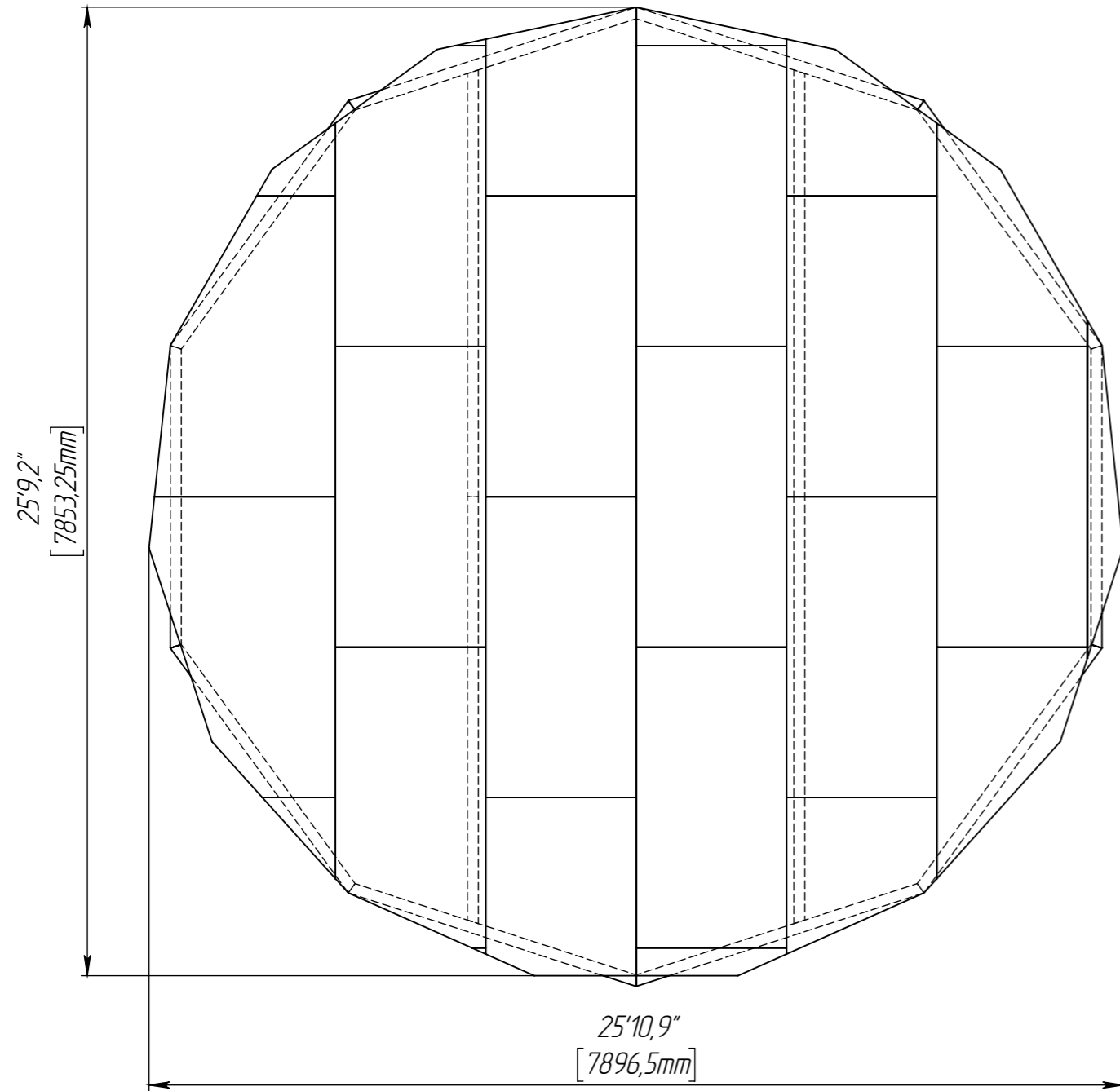
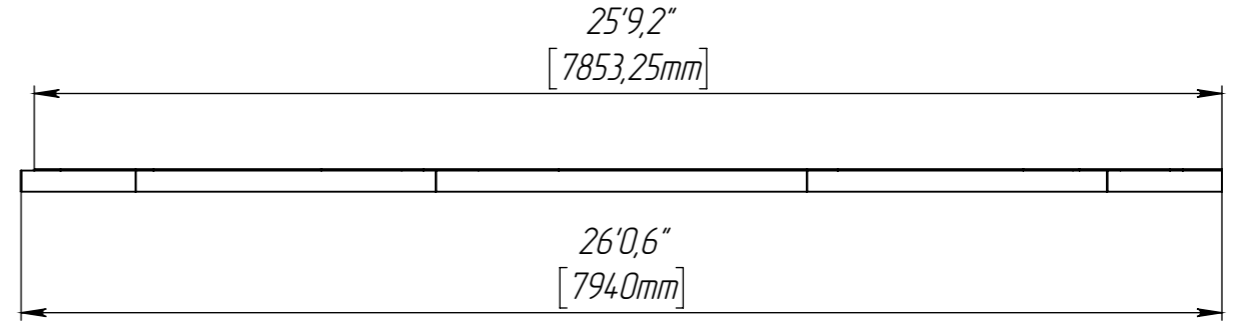
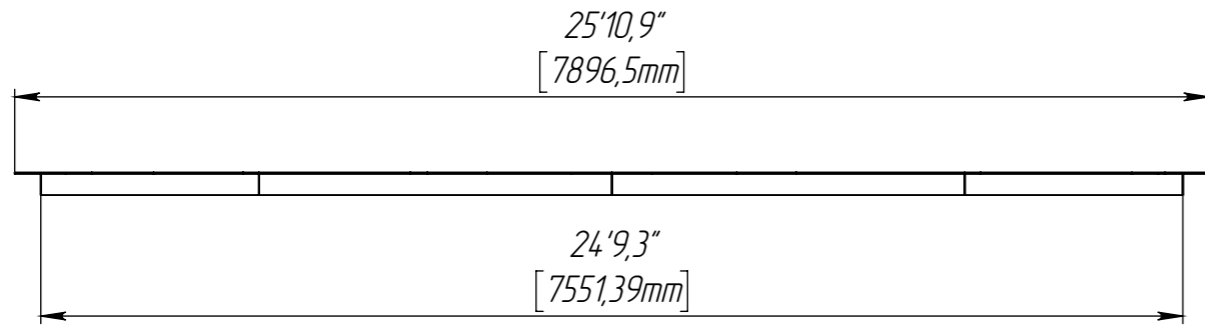

Bottom Plywood Layout over Runners

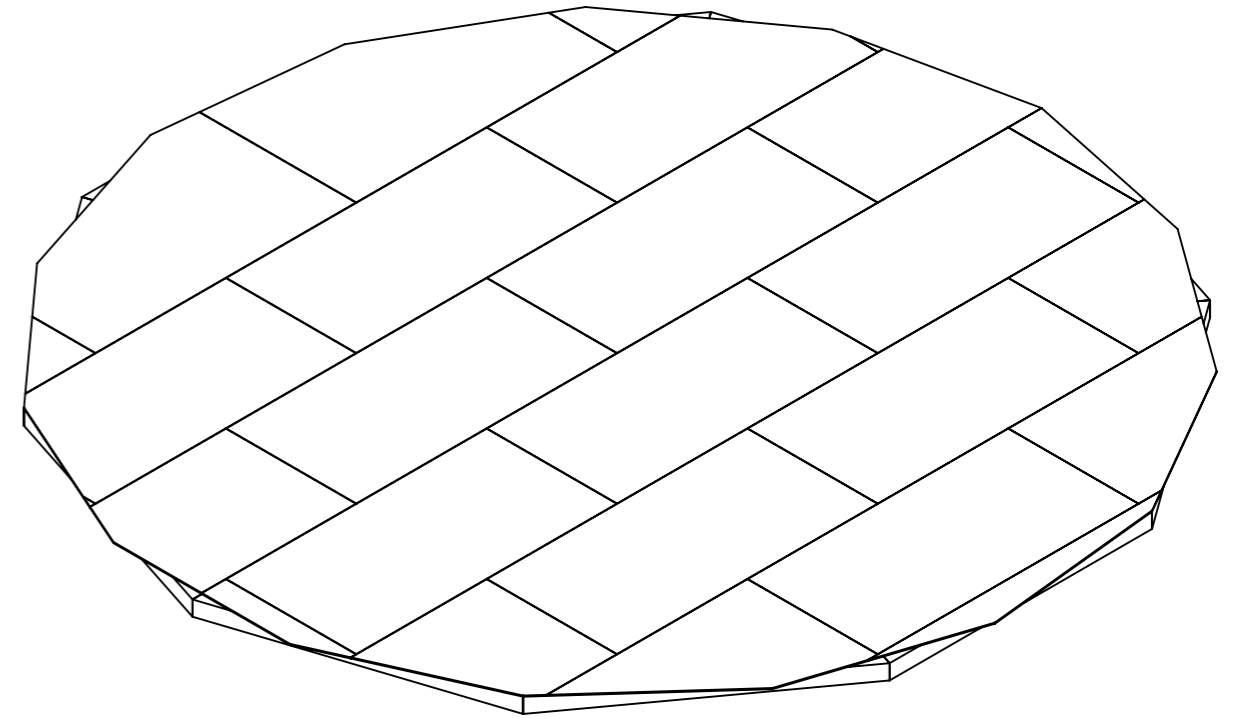

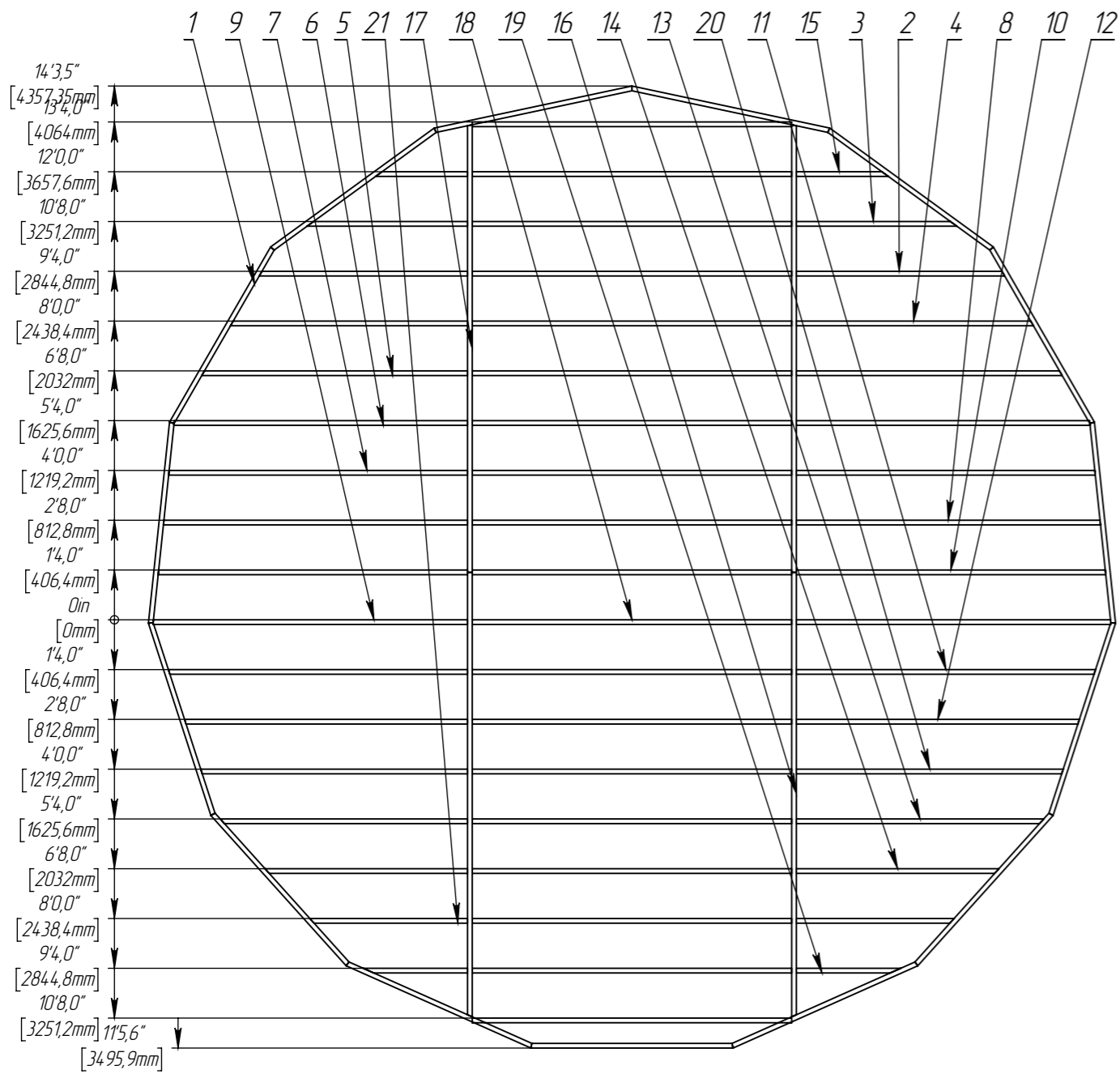

ITEM NO.	QTY.	Description	LENGTH	ANGLE1	ANGLE2	TOTAL LENGTH
1	15	Lumber 2x6	5'5.0"	12°	12°	508'4.1"
2	2	Lumber 2x6	5'7.0"	30°	0°	
3	2	Lumber 2x6	4'3.6"	54°	0°	
4	2	Lumber 2x6	6'4.2"	30°	0°	
5	2	Lumber 2x6	7'1.4"	30°	0°	
6	2	Lumber 2x6	7'10.4"	6°	0°	
7	2	Lumber 2x6	8'0.1"	6°	0°	
8	2	Lumber 2x6	8'1.8"	6°	0°	
9	2	Lumber 2x6	8'5.1"	6°	0°	
10	2	Lumber 2x6	8'3.4"	6°	0°	
11	2	Lumber 2x6	8'0.2"	18°	0°	
12	2	Lumber 2x6	7'7.0"	18°	0°	
13	2	Lumber 2x6	6'7.5"	42°	0°	
14	2	Lumber 2x6	5'5.1"	42°	0°	
15	2	Lumber 2x6	2'5.6"	54°	0°	
16	2	Lumber 2x6	11'10.8"	0°	24°	
17	2	Lumber 2x6	11'11.9"	12°	0°	
18	19	Lumber 2x6	8'6.7"	0°	0°	
19	2	Lumber 2x6	2'9.5"	66°	0°	
20	2	Lumber 2x6	7'1.8"	18°	0°	
21	2	Lumber 2x6	4'2.7"	42°	0°	

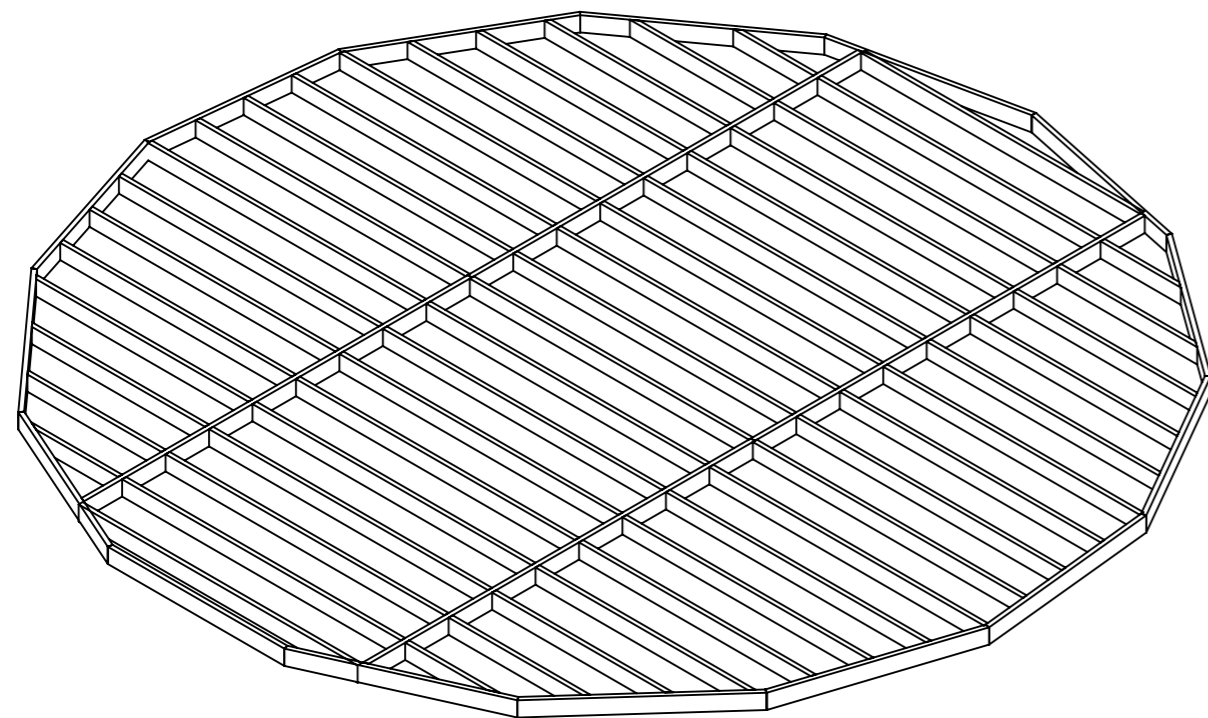

Joists with Length and Cut Angels
Joists with Length and Cut Angels

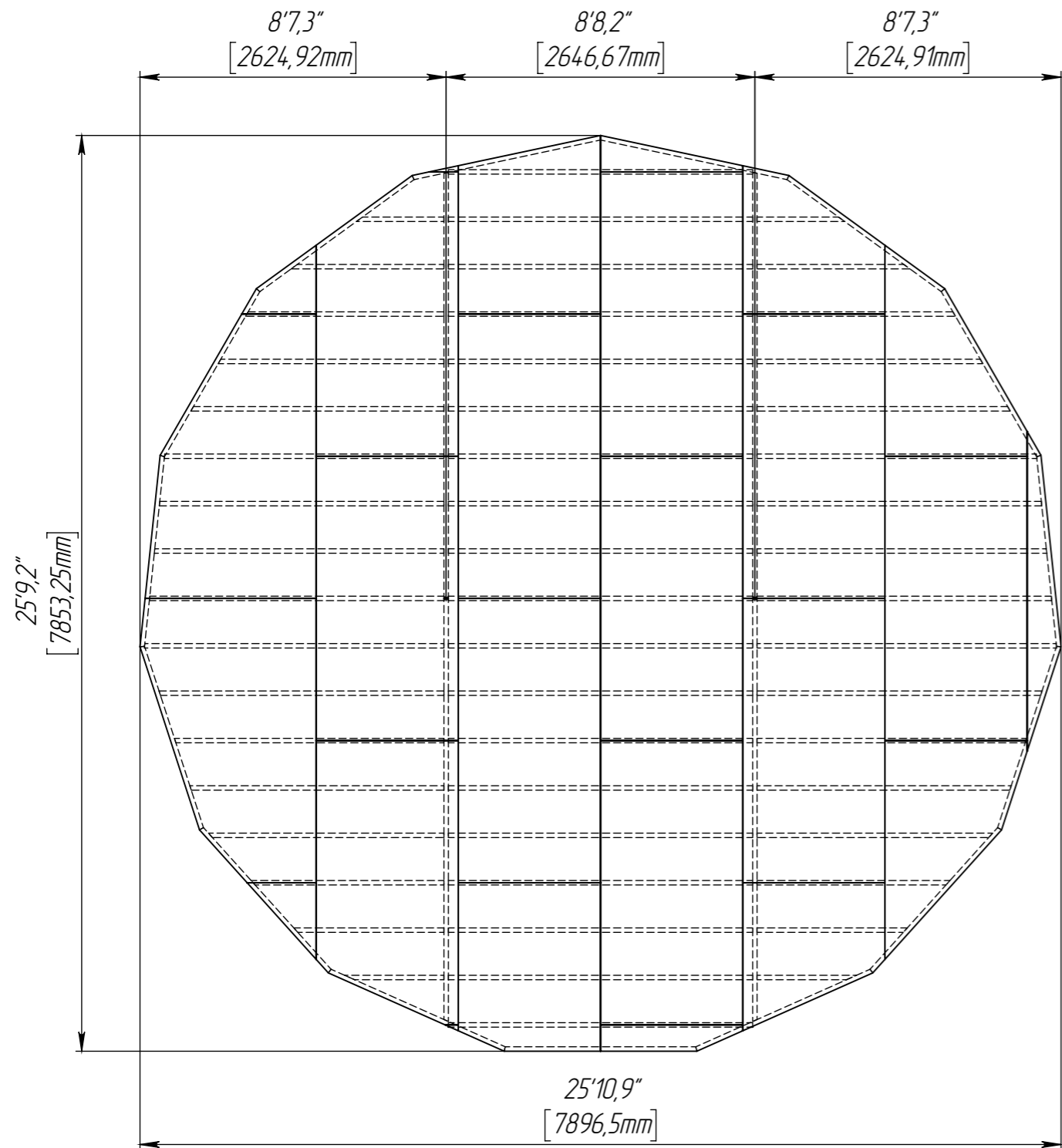
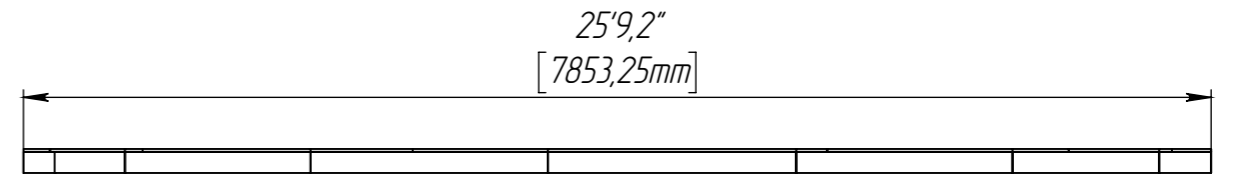
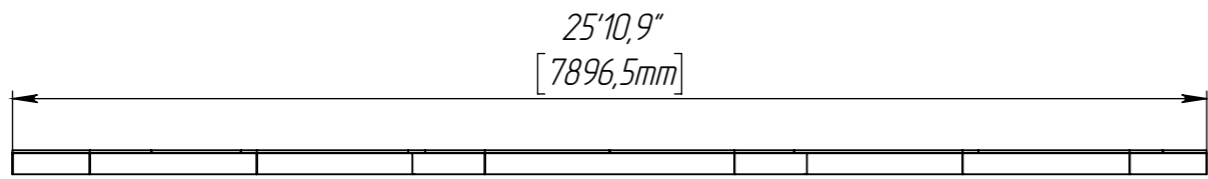

Top Plywood Layout over Joists

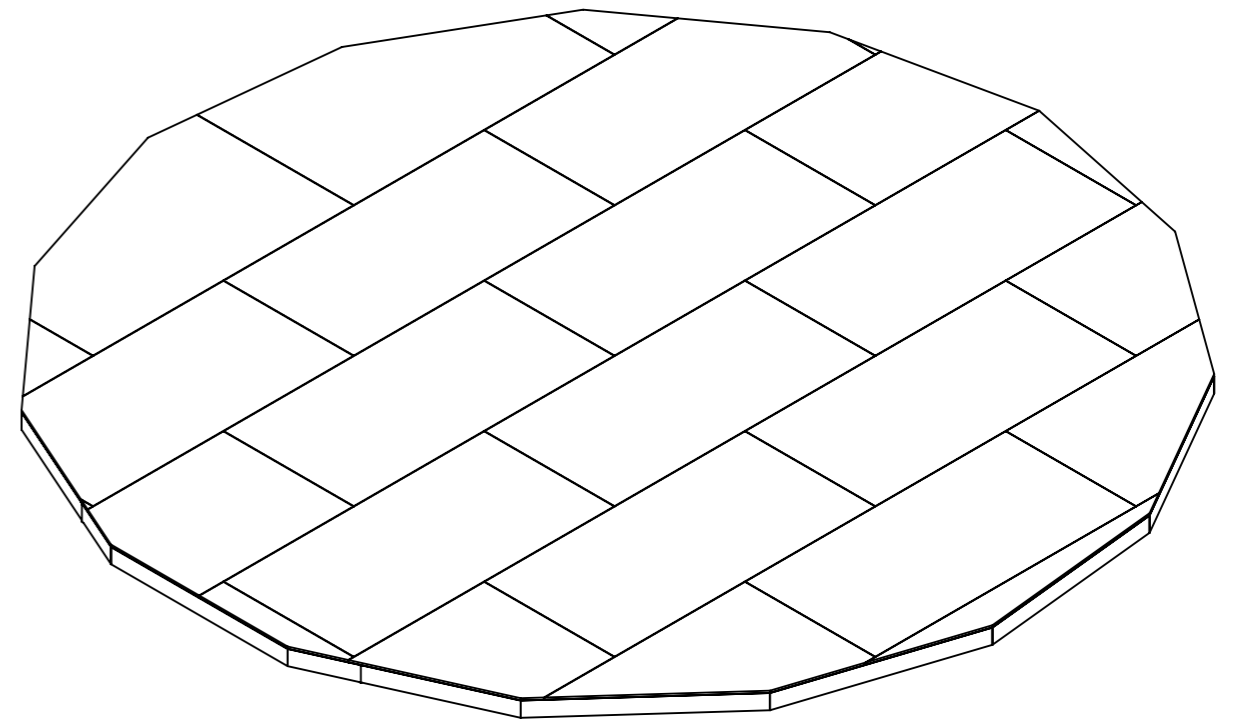

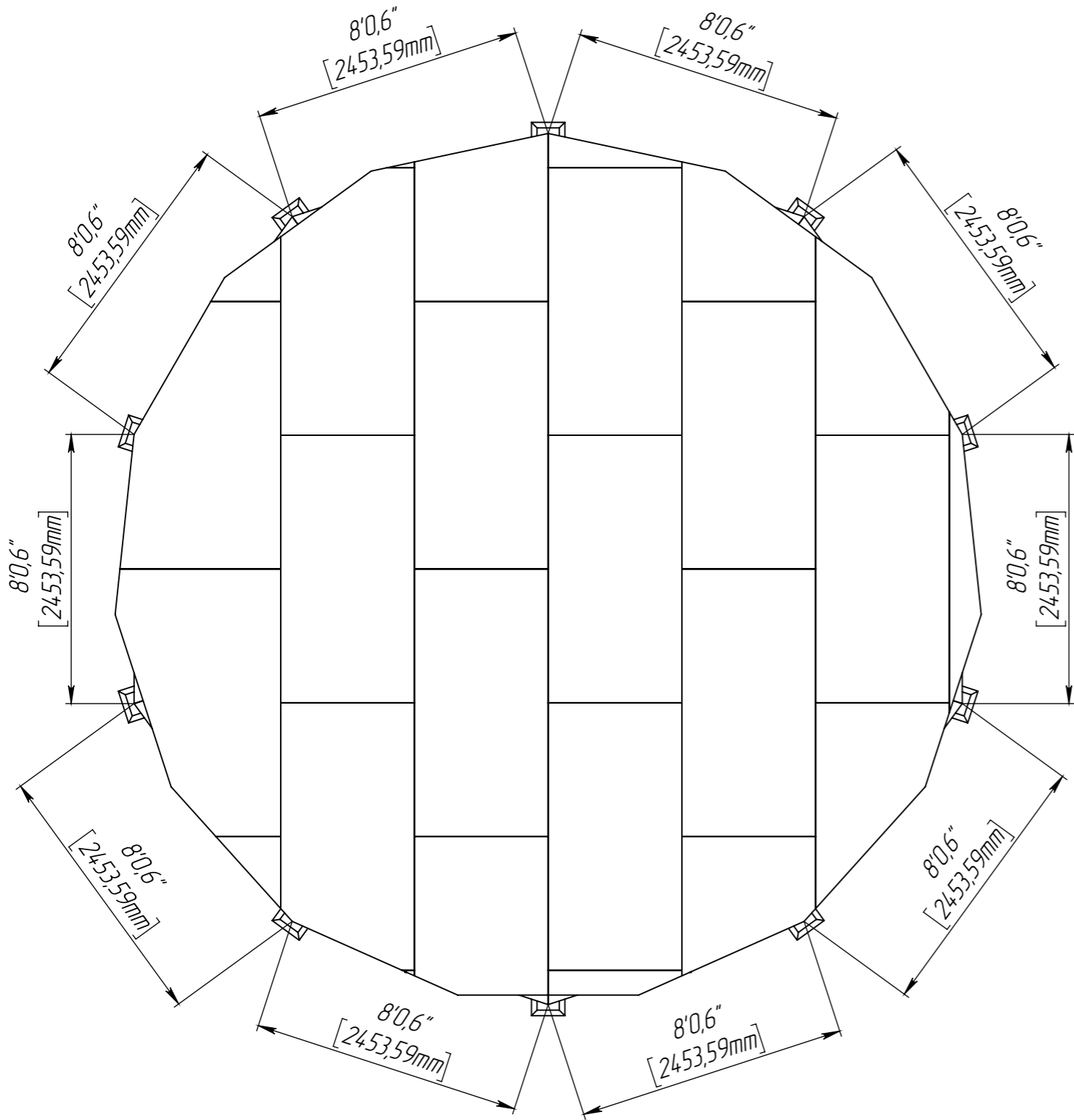
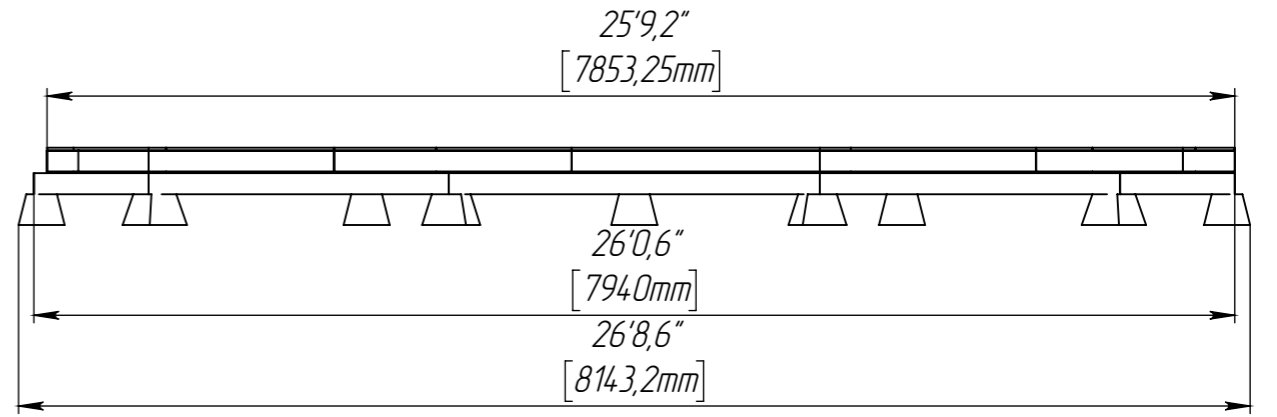
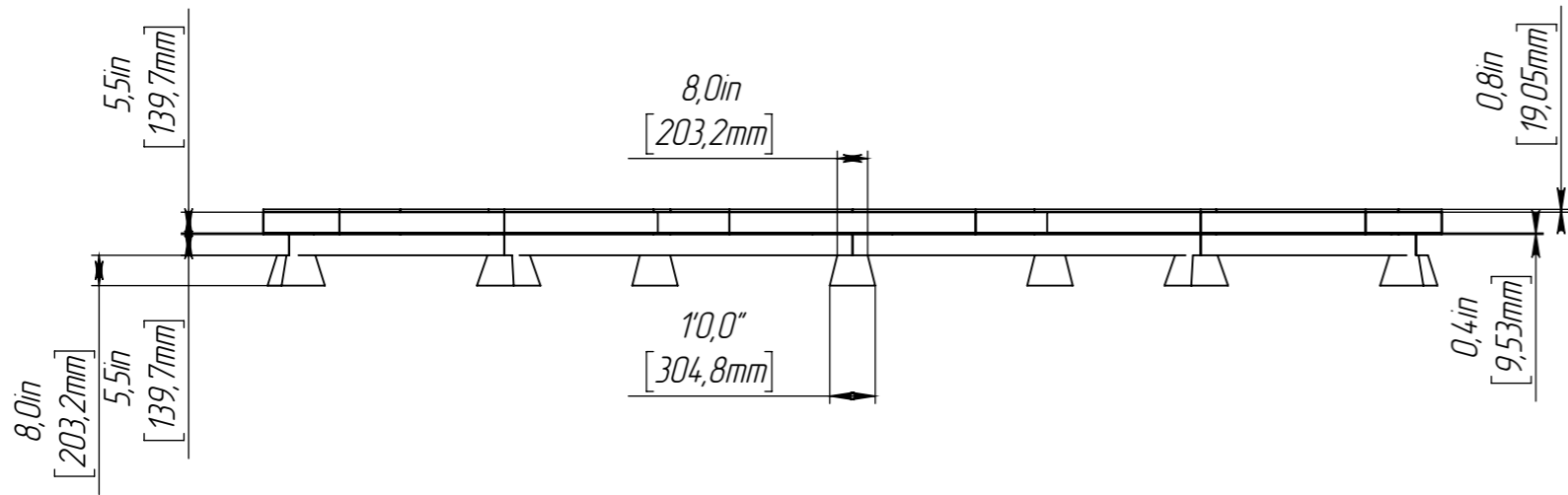

Top and Bottom Plywood Layout

