

zip **SERIES**

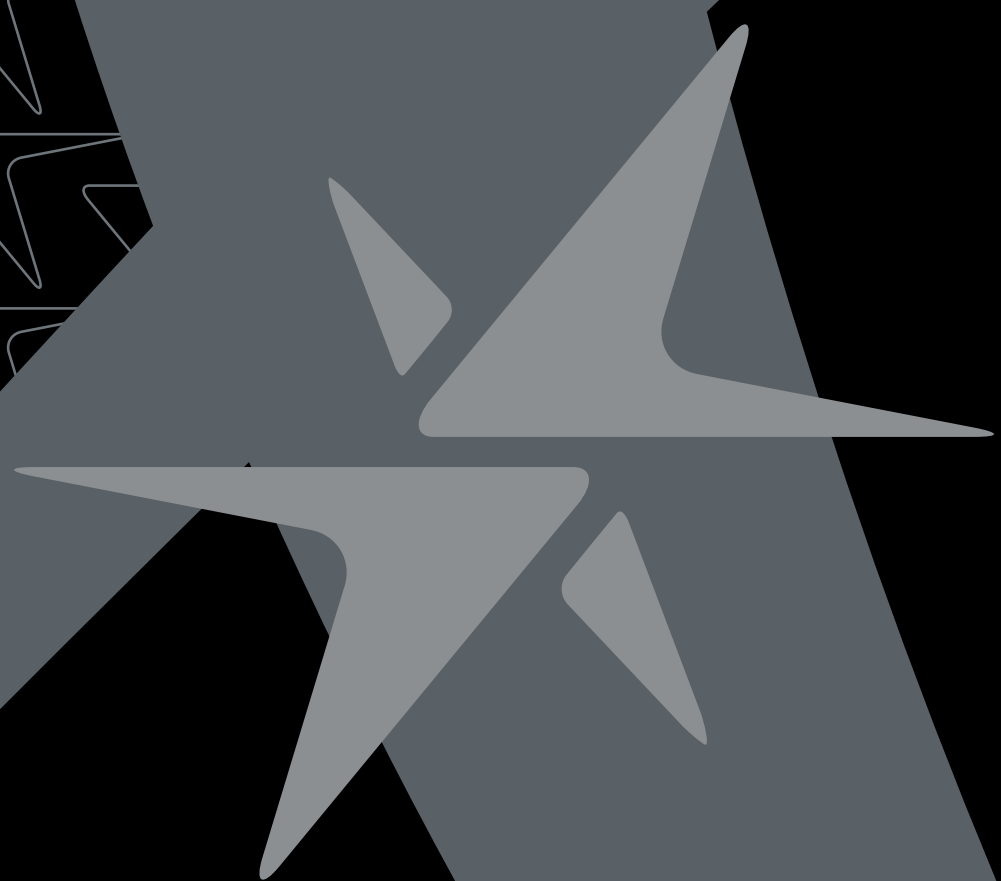

**MGI**™

**zip** *X1*

**User** Manual

VERSION 4.3

**Thank you for purchasing the Game Changing MGI Zip X1. To get the most out of your Zip X1 please follow these quick steps before use.**

- Register your Zip X1 online [section 1.0]
- Assembling the Zip X1 [section 3.0]
- Charge the battery [section 4.0]

For Customer Support, please contact MGI directly for immediate and professional advice.

**mgigolf.com**

#### **MGI AUSTRALIA**

**Service Email:** customerservice@mgigolf.com

**Live Chat:** visit mgigolf.com

**Toll Free within Australia:** 1300 644 523 (excludes mobiles)

Western Australia/ Internal phone +61 3 8872 6700

**Local Service Centres:** visit mgigolf.com to locate you local service centre.

#### **MGI USA**

**Service Email:** serviceusa@mgigolf.com

**Live Chat:** visit mgigolf.com

**Telephone:** 1800 617 2990

#### **MGI GLOBAL**

**Sales Email:** globalsales@mgigolf.com

**Service Email:** customerservice@mgigolf.com

**Live Chat:** visit mgigolf.com

**NOTE:** This user manual was correct at time of printing. The online version is the most up-to-date and must be referred to as the correct version. To download the most current user manual please visit [www.mgigolf.com](http://www.mgigolf.com). Images shown throughout this manual may not be of the particular model you have purchased.



## Contents

<b>1.0</b>	<b>Registration</b>	<b>04</b>
<b>2.0</b>	<b>What Is Included</b>	<b>04</b>
<b>3.0</b>	<b>Assembling the Zip X1</b>	<b>05</b>
<b>3.1</b>	Attaching the Rear Wheels	<b>05</b>
<b>3.2</b>	Rear Wheel Positions	<b>06</b>
<b>3.3</b>	Unfolding	<b>07</b>
<b>3.4</b>	Folding	<b>08</b>
<b>3.5</b>	Foldable Fourth Wheel	<b>09</b>
<b>3.6</b>	GPS Holder and Top Handle Compartment	<b>09</b>
<b>3.7</b>	Inverting Rear Wheels	<b>09</b>
<b>4.0</b>	<b>Battery Charging &amp; Connection</b>	<b>10</b>
<b>4.1</b>	Initial Charge	<b>10</b>
<b>4.2</b>	Connecting the Battery onto the Zip X1	<b>10</b>
<b>4.3</b>	Charging the Battery after Use	<b>11</b>
<b>5.0</b>	<b>Fitting the Golf Bag</b>	<b>11</b>
<b>6.0</b>	<b>Operating the Digital Top Box</b>	<b>12</b>
<b>6.1</b>	Top Box Display	<b>12</b>
<b>6.2</b>	Start / Stop the Zip X1	<b>12</b>
<b>6.3</b>	Turn the Zip X1 Off	<b>13</b>
<b>7.0</b>	<b>Front Wheel Alignment</b>	<b>13</b>
<b>8.0</b>	<b>Warranty</b>	<b>15</b>
<b>8.1</b>	Warranty Policy	<b>15</b>
<b>8.2</b>	Warranty Exclusions	<b>16</b>
<b>8.3</b>	Parts Installed During Warranty	<b>17</b>
<b>9.0</b>	<b>Preventative Maintenance Program</b>	<b>17</b>
<b>9.1</b>	Cleaning Your Zip X1	<b>17</b>
<b>9.2</b>	Rear Wheel Axles Maintenance	<b>17</b>
<b>9.3</b>	Upper and Lower Bag Strap	<b>18</b>
<b>9.4</b>	MGI Service Schedule	<b>18</b>
<b>9.5</b>	Service Record	<b>19</b>
<b>10.0</b>	Service and Repair Centres	<b>20</b>
<b>11.0</b>	Purchasing Parts and Accessories	<b>20</b>
<b>12.0</b>	Contacting MGI	<b>20</b>
<b>13.0</b>	Contacting Local Agent	<b>21</b>
<b>14.0</b>	Frequently Asked Questions	<b>21</b>

## I.O Registration

It is most important you register your MGI Zip X1 online immediately as registration:

- Records your Zip X1 for warranty purposes
- Speeds up any servicing required on your Zip X1
- Assist us to contact you with any updates to your Zip X1

To register your Zip X1, visit **mgigolf.com**

You will need to record your MGI serial number. This is found on the Zip X1 battery base or in the top box compartment.

Please keep this user manual on file for your own reference and a copy of your serial number;

### My MGI Zip X1 Serial Number is

[example AZX1V1173401234]

--	--	--	--	--	--	--	--	--	--	--	--	--	--	--

### Purchased Date

--	--	--	--	--	--	--	--

You may be required to show proof of purchase so we recommend you keep your receipt with this manual.

## 2.0 What`s Included

- MGI Zip X1
- 24v Lithium Battery
- Battery Charger
- GPS Holder
- MGI Pouch with:
  - User Manual
  - Accessory Guide



## 3.0 Assembling Your Zip X1

### 3.1 Attaching the Rear Wheels



**Step 1.** Each wheel is labelled with L or R for left or right. This is very important as the wheels must be placed on the correct side of the Zip X1. Left or right sides are determined when standing behind the Zip X1 as pictured above.



**Step 2.** On the wheel, press the grey release button on the wheel hub. Place the wheel onto the axle. You will notice you need to match up the inner female groove on the axle and the male of the wheel. When placed in position simply release the button. You will notice you hear a "click" when the wheel is properly secured. To check that the wheel is properly in position pull on the wheel. If it is properly in position it will not slide off. Repeat for the other wheel.



### 3.2 Rear Wheels Positions

The MGI Zip X1 is designed to allow the rear wheels to be in two positions. The position is determined by where the wheel is locked on the axle in either of the two grooves [see picture]. The drive position is used during the normal operation of the Zip X1. The free wheel position is used to freely push the Zip X1 should you experience battery or Zip X1 issues on the course.

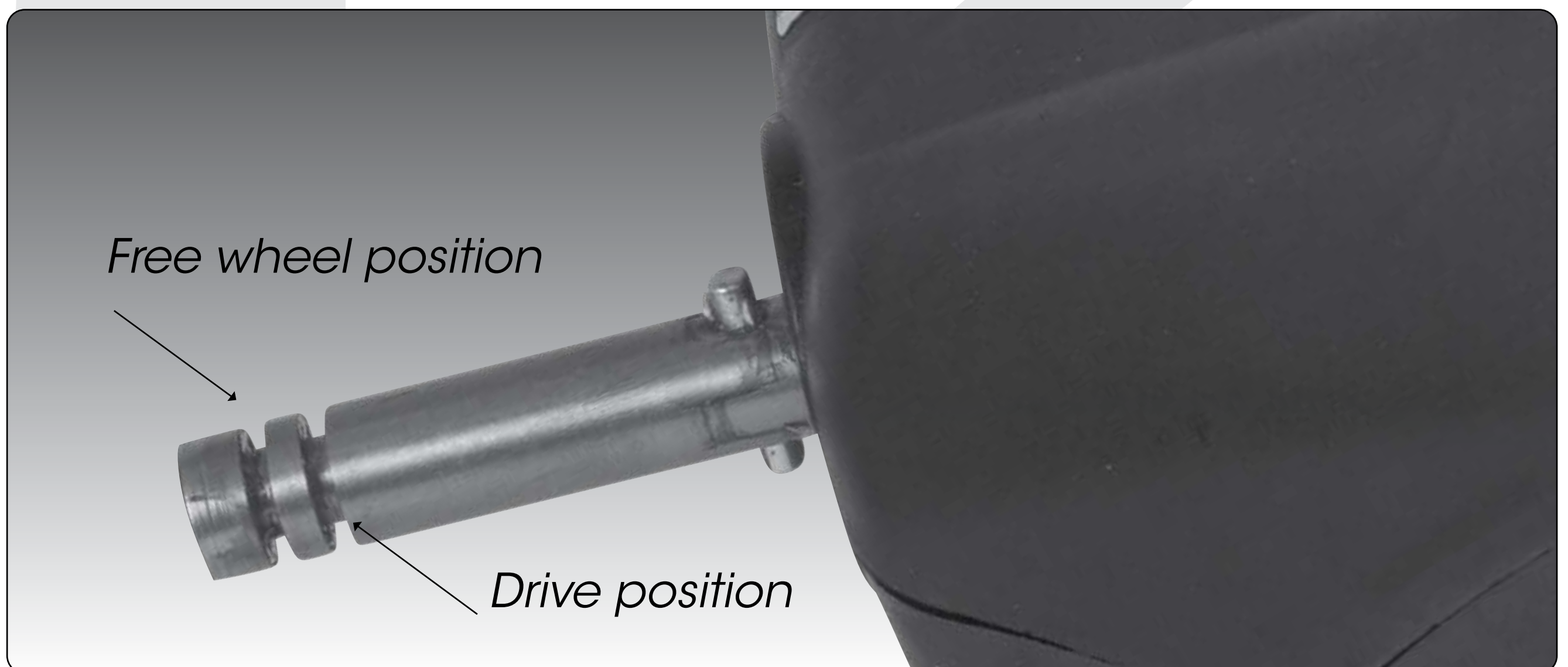

**i. Drive position** – Lock the wheel onto the groove closest to the battery base. To do this, press the grey release button on the wheel hub, push the wheel on to the axle as far as possible. To test for drive position try rolling the wheel backwards. If you feel resistance then the wheel is now in drive position and ready to use. Repeat for both wheels.

**ii. Free wheel** – Lock the wheel into the groove closest to the end of the axle. To do this, press the grey release button on the wheel hub, push the wheel on to the axle and release the release button onto the groove. To test for free wheel position try rolling the wheel backwards. The wheel should spin freely with no resistance. Repeat for both wheels.



### 3.3 Unfolding

Please see below the steps to unfold a Zip X1 Handle.



**Step 1:** Ensure both rear wheels are attached.

**Step 2:** Release Fold Lever.



**Step 3:** Move Top Bag Support away from front wheel assembly until you hear it click.

**Step 4:** The handle is now free to pull upwards. The handle will naturally unfold as you continue to pull until the handle is completely open.



**Step 5:** Ensure that the latch at the bottom of the handle clicks into place.

**Step 6:** Close the fold lever to lock the handle into place in one of three positions.

**Step 7:** Push the top bag support down to move it into position.

### 3.4 Folding



**Step 1:** Disconnect the battery by lifting the battery handle. It can be left on or removed from the Zip X1.



**Step 2:** Open the fold lever to release the handle.



**Step 3:** Pull up the latch at the bottom of the handle.



**Step 4:** Lower the handle down flat.

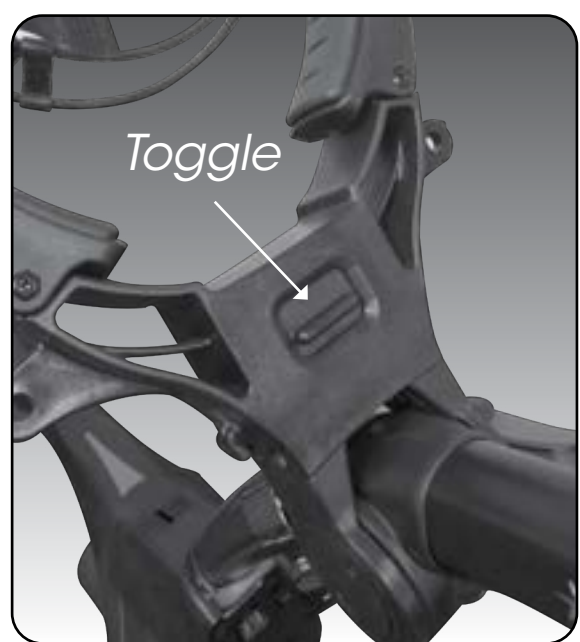

**Step 5:** Push the toggle down on the top bag support and then move the Top Bag Support down so that it locks over the front wheel assembly.



**Step 6:** Close the fold lever to lock the handle into place.



### 3.5 Fourth Foldable Rear Wheel

The MGI Zip X1 comes standard with a fourth foldable rear wheel. This wheel **MUST** be unfolded into position at all times when the Zip X1 is in use. This will reduce damaging the Zip X1, and provide the ultimate in stability across all terrains. This fourth wheel should be cleaned regularly with a cloth to ensure it can be folded as required for storage.



### 3.6 GPS Holder and Top Handle Compartment

In the top handle compartment there is a position for a GPS/mobile device holder. Open the compartment and connect the holder into position. To open the holder always press the button at the top of the holder. Place the GPS into the cradle, then close the holder by squeezing the two sides closer together.



### 3.7 Inverting Rear wheels

The rear wheels can be inverted on the axle to reduce the size of the Zip X1 when folded. To invert the rear wheels, press the grey release button on the wheels hub and remove from the axle. Invert the rear wheels so that the wheels hub protrudes away from the axles. Press the grey release button on the wheels hub and release once the wheel is fitted onto the axle.



## 4.0 Battery Charging & Connection

The Zip X1 is designed to take either Zip battery:

- MGI 24v 250Wh Lithium battery [Standard]
- MGI 24v 299Wh Lithium battery [Optional]

### 4.1 Initial Charge

- Before using your MGI Zip X1 for the first time you must fully charge the battery overnight.
- Plug the charger AC lead into a power point - the Green LED illuminates to indicate the charger is power on.
- Plug the charger output connection into the connector on the front of the battery - the Red LED illuminates to indicate charging.
- When the charging LED indicator has turned green, the battery is fully charged and ready to be used.



Please refer to the battery charger user manual for further information.

### 4.2 Connecting the Battery onto the Zip X1

Position the battery on the Zip X1 and push the battery down to secure it.



Push the handle down to connect the battery to the Zip X1.

Your Zip X1 has been equipped with fail safe battery connection, so the Zip X1 will not move when you connect the battery. Your Zip X1 will only start once the speed control is switched on.



### 4.3 Charging the Battery after Use

- Disconnect the battery by lifting the handle.
- The battery can be left on or removed from the Zip X1 for charging.
- Plug the charger AC lead into a power point - the Green LED illuminates to indicate the charger is power on.
- Plug the charger output connection into the connector on the front of the battery - the Red LED illuminates to indicate charging.
- When the charging LED indicator has turned green, the battery is fully charged and ready to be used.

### 5.0 Fitting the Golf Bag

Ensure that the top bag support straps are disconnected. Position the golf bag on the Zip X1.

Secure the top bag support strap

- Select a good position for the elasticised straps to be put around the golf bag
- Stretch the longer end of the strap and loop the rounded plastic bar underneath the hook on the shorter end
- The top bag support straps should now be connected.



Please ensure the top bag support straps are hooked in place securely before releasing. Failure to do so could result in injury to the user.

#### Adjusting the length of the top bag support strap

The rounded plastic bar on the longer strap can be adjusted to ensure the bag is secured properly in place.

Secure the lower bag strap

Pull the lower bag strap over the base of the golf bag

## 6.0 Operating the Digital Top Box

### 6.1 Top Box Display



#### Light 1: Zip X1 active

A green light will appear on the left hand side when the Zip X1 is active and moving.

#### Light 2: Battery indication

The light on the right hand side displays the battery status. There are three colours of battery status: Green [charged], Amber [low] and Red [very low].

**Number Display:** This shows the speed setting 1 to 9. The higher the number the higher the speed.

### 6.2 Start / Stop the Zip X1



#### Zip X1 Speed Control

Please note the following points regarding the Zip X1 Speed Control.

1. To select the desired speed, rotate the speed control button.  
Turning the speed control button clockwise will increase the speed, whilst anti-clockwise will decrease speed.
2. The speed setting chosen is displayed in the centre of the coloured screen.  
*Please note you will feel notches as you rotate the speed control. The notches do not indicate a change in speed. The speed will only increase or decrease as the number changes in the display.*
3. To start the Zip X1 at this desired speed, tap the top of the speed control button.
4. Another tap will stop the Zip X1.
5. The desired speed can be altered up or down while the Zip X1 is moving.



## 6.3 Turn the Zip X1 Off

### Zip X1 Battery

Please note the following points regarding the Zip X1 Battery.

#### Connecting the Battery onto the Zip X1

1. Position the battery on the Zip X1 and push the battery down to secure it. Push the battery handle down to connect the battery to the Zip X1.
2. To turn the Zip X1 Top Box Display off:  
Hold down the Start/Stop Speed Control Button for four seconds and the display will turn off thereby disabling the Top Box.

***Please note that the battery will still be connected to the Zip X1 and will continue to drain whilst connected.***

Please note that the Zip X1 display will also turn off if the Speed Control is not operated for 30 minutes.

***Once again, please note that the battery will still be connected to the Zip X1 and will continue to drain whilst connected.***

To reactivate the Top Box Display, whilst the battery is connected, hold down the Start/Stop Speed Control Button for four seconds and the display will turn on thereby enabling the Top Box.

To fully shut down the Zip X1 and prevent the battery from discharging, disconnect the battery by lifting its handle. The battery can be left on or removed from the Zip X1.

## 7.0 Front Wheel Alignment

During the life of your Zip X1, it may require a realignment to ensure it tracks straight on flat surfaces. Follow these instructions to correct the front wheel alignment of the Zip X1.

**Step 1:** Release and turn the lever to loosen the front wheel.



**Step 2:** There are two silver thumb screws located on either side of the front wheel. Adjusting these screws will help straighten the alignment by correcting the Zip X1 to track more to the left or the right.



→ *Thumb Screw*

Roll the left or right hand side silver thumb screw UP to straighten the Zip X1 more to the LEFT.

Roll the left or right hand side silver thumb screw DOWN to straighten the Zip X1 more to the RIGHT.

You can roll the screws simultaneously or individual to achieve the desired alignment.

**Step 3:** Once alignment is set, turn the lever and tighten. Then close the lever.



→ *Tighten*

**TIP:** When adjusting the front wheel and testing the alignment, ensure the Zip X1 is run on a flat, smooth surface like a carpark.



## 8.0 Warranty

### 8.1 Warranty Policy

The MGI Zip X1 is covered by a limited 3 year manufacturer's warranty from the date of purchase. Duration of this warranty is:

- 3 years on parts\*
- 3 years on Lithium batteries and chargers

\*MGI or an authorised service centre will repair or replace any parts found to be defective in materials or workmanship under normal use provided that:

1. The MGI Zip X1 has been properly used, maintained and regularly serviced [see section 10.5]
2. The replacement or repair is performed by an authorised MGI service centre or the owner with MGI approval.
3. The Zip X1 has been registered online.

Our goods come with guarantees that cannot be excluded under Consumer Law. You are entitled to a replacement or refund for a major failure and for compensation for any other reasonably foreseeable loss or damage. You are also entitled to have the goods repaired or replaced if goods fail to be of acceptable quality and the failure does not amount to a major failure. This warranty is in addition to other rights and remedies available to the consumer under law. The consumer is responsible for expenses associated with a warranty claim. To make a warranty claim, cease using the goods immediately and contact MGI directly using the contact details on the back of this User Manual. Proof of purchase is mandatory.

## 8.2 Warranty Exclusions

The following events will void warranty:

- Any alteration performed by non-authorized people or companies.
- Fitting of parts or accessories not recommended by MGI.
- Any damage caused by continued operation of the product after it is known to be defective.
- Damage to the seat and/or seat support bracket on the unit.
- Damage caused by partial or complete ingress of water into motor/gearbox and other major components.
- Damage caused by the unit being driven into bunkers, other course hazards or clubhouse and carpark hazards.
- Damage caused by golf balls or golf clubs.
- Application of external force to any part of the unit or battery.
- Fusion of motor or electronics through overload or continual stationary operation.
- All implied warranties [save those preserved by statute] are excluded.
- Liability for consequential damages under any and all warranties are excluded to the extent exclusion is permitted by law.

In the event of submersion in water (partial or full) of a motorised buggy; MGI advises the complete write-off of your buggy.

The cost of replacing the water-damaged components (including labour) exceeds the price of a replacement buggy.

If you elect to purchase replacement components, i.e. motors, gearbox, motor controller and electronics, we advise the replacement of ALL components simultaneously. Replacing individual components on a water-damaged buggy poses a higher risk of future failure of other components and therefore these parts will not be covered under warranty.

Please note that MGI does not warrant water-damaged batteries and, due to fire risk, under no circumstances should they continue to be used.

The following events are not covered under warranty:

Normal wear and tear;

- (e.g. tyres, rubber handlebar, elastic straps, paintwork, battery performance, axles threads, charging ports on batteries and remotes, screen glass etc.)
- Minor appearance defects which bear no effect on the operation of the unit and are considered by the manufacturer to be within the accepted standards.



### **8.3 Parts Installed During Warranty**

Warranty coverage for components installed during a motorised Zip X1's warranty period shall consist of the duration of the Zip X1's warranty period, provided the warranty installation is performed by MGI, an authorised service centre or the Zip X1 owner on approval.

Replacement of parts under warranty will not extend the warranty of the Zip X1 or parts.

## **9.0 Preventative Maintenance Program**

To properly provide for the continued operation of your MGI Zip X1, MGI has introduced its Preventative Maintenance Program [PMP]. The PMP consists of work to be carried out by both the owner and authorised service centres. To properly maintain the warranty of your MGI Zip X1, it is essential that this work is carried out. If the work carried out by the authorised service centre is to replace parts that are part of the maintenance schedule, the owner will be charged for the parts and labour. If the work to be carried out is part of warranty, MGI will bear the cost.

### **9.1 Cleaning Your Zip X1 [See Maintenance Schedule]**

- For years of good operation, your Zip X1 requires care and attention.
- Keep your Zip X1 clean by using a cloth with warm water and a mild detergent.
- Do not hose down your Zip X1 under any circumstance, as the Zip X1 has electronic components.
- Ensure that the seat stem bracket is free from sand.
- Do not submerge your Zip X1 in water as it will cause irreparable damage.
- Clean the Zip X1 battery base when the battery is removed from the Zip X1.

### **9.2 Rear Wheel Axles Maintenance [See Maintenance Schedule]**

The rear wheel stub axles need to be lubricated regularly. Remove the rear wheels by depressing the spring clip and at the same time pull off the wheel. Apply Petroleum Jelly or light grease to the stub axles. Use a very small amount as the grease can attract sand. If you play in sandy conditions you should clean the axle and regrease fortnightly.

### 9.3 Upper and Lower Bag Strap Maintenance [See Maintenance Schedule]

The bag straps should be replaced as per the Service Schedule. The upper bag strap can be replaced by:

- Removing the left and right hand straps from the upper bag support
- Undo and remove the screws holding the strap in position on the bag support
- Remove and replace both bag straps
- Insert bag strap securing screws.

### 9.4 MGI Service Schedule

It is the owner's responsibility to ensure that all periodical checks, necessary adjustments and services are carried out. If in doubt please contact the MGI service centre:

**Australia** 1300 644 523

**USA** 1800 617 2990

Any work performed on your buggy should be recorded on your service record (see page 21) regardless of the work.

MGI Zip X1	Monthly	6 Monthly	Every 2 yrs	Every 3 yrs
Wipe down the Zip X1 with a warm cloth after each use [do not hose]	BO			
Lubricate rear wheel stub axles	BO			
Check and tighten nuts and bolts		BO		
Check and tighten handle pivots		BO		
Check alignment of Zip X1 – ensure that it runs straight		BO		
Replace Speed Controller and On/Off switch assembly				BO /SC
Replace rear and front wheels				BO
Replace upper and lower bag straps				BO

BO = Zip X1 owner can carry out this work

SC = Charged work to be carried by approved service centre

BO/SC = The six monthly service can be completed by either an authorised service centre or the owner of the Zip X1.



## 9.5 Service Record

<b>6 month inspection</b>	Date: Invoice #:	Serviced by: Signature:
<b>1 year inspection</b>	Date: Invoice #:	Serviced by: Signature:
<b>1 ½ year inspection</b>	Date: Invoice #:	Serviced by: Signature:
<b>2 year inspection</b>	Date: Invoice #:	Serviced by: Signature:
<b>2 ½ year inspection</b>	Date: Invoice #:	Serviced by: Signature:
<b>3 year inspection</b>	Date: Invoice #:	Serviced by: Signature:
<b>3 ½ year inspection</b>	Date: Invoice #:	Serviced by: Signature:
<b>4 year inspection</b>	Date: Invoice #:	Serviced by: Signature:
<b>4 ½ year inspection</b>	Date: Invoice #:	Serviced by: Signature:
<b>5 year inspection</b>	Date: Invoice #:	Serviced by: Signature:
<b>5 ½ year inspection</b>	Date: Invoice #:	Serviced by: Signature:
<b>6 year inspection</b>	Date: Invoice #:	Serviced by: Signature:

## 10.0 Service and Repair Centres

For all servicing, please do not go back to your place of purchase.

To find your nearest Service centre visit [mgigolf.com](http://mgigolf.com)

For warranty repairs to be authorised you MUST provide proof of purchase. Please keep this with you as well as your Serial number you can record in this manual. It is most important you register your MGI Zip X1 online for warranty purposes.

## 11.0 Purchasing Parts and Accessories

You are welcome to service your Zip X1 out of warranty, by purchasing parts direct from MGI. Please call or email to discuss the right parts and instructions.

## 12.0 Contacting MGI

**[mgigolf.com](http://mgigolf.com)**

### **MGI AUSTRALIA**

**Service Email:** [customerservice@mgigolf.com](mailto:customerservice@mgigolf.com)

**Live Chat:** visit [mgigolf.com](http://mgigolf.com)

**Toll Free within Australia:** 1300 644 523 (excludes mobiles) Western Australia/ Internal phone +61 3 8872 6700

**Local Service Centres:** visit [mgigolf.com](http://mgigolf.com) to locate you local service centre.

### **MGI USA**

**Service Email:** [serviceusa@mgigolf.com](mailto:serviceusa@mgigolf.com)

**Live Chat:** visit [mgigolf.com](http://mgigolf.com)

**Telephone:** 1800 617 2990

### **MGI GLOBAL**

**Sales Email:** [globalsales@mgigolf.com](mailto:globalsales@mgigolf.com)

**Service Email:** [customerservice@mgigolf.com](mailto:customerservice@mgigolf.com)

**Live Chat:** visit [mgigolf.com](http://mgigolf.com)



## **13.0 Contacting Local Agent**

Please refer to [mgigolf.com](http://mgigolf.com) to find the distributor in your country.

## **14.0 FAQ**

**Q: I would like to have my MGI Zip X1 serviced. Who do I call?**

**A: MGI AUSTRALIA**

Visit [mgigolf.com](http://mgigolf.com) to find your nearest service centre using your postcode within Australian and New Zealand.

You can also call MGI Head office using any of the contact details. See Section 13.0 for details. Internationals please call your local agent as per Section 14.0

### **MGI USA**

Call 1800 617 2990

Email: [serviceusa@mgigolf.com](mailto:serviceusa@mgigolf.com)

### **MGI GLOBAL**

Email: [customerservice@mgigolf.com](mailto:customerservice@mgigolf.com)

# zip SERIES



# MGI™

**mgigolf.com**

**MGI AUSTRALIA  
MGI HEAD OFFICE**

11 Maurice Court Nunawading 3131  
Victoria Australia

**T** +61 3 8872 6700 **E** sales@mgigolf.com

**SERVICE** customerservice@mgigolf.com

**MGI USA**

**T** 1800 617 2990 **E** salesusa@mgigolf.com

**SERVICE** serviceusa@mgigolf.com

**MGI GLOBAL**

**E** globalsales@mgigolf.com

Follow us on



*Absolute attention has been taken to ensure this manual is correct at time of printing. Specifications, images and statistics may change at any time.*

*Visit [www.mgigolf.com](http://www.mgigolf.com) for the most current model information. Version 4.2*