

Aluminum Steel

External Mount Steel or Aluminum 4 or 5 Spring Tarp Kit

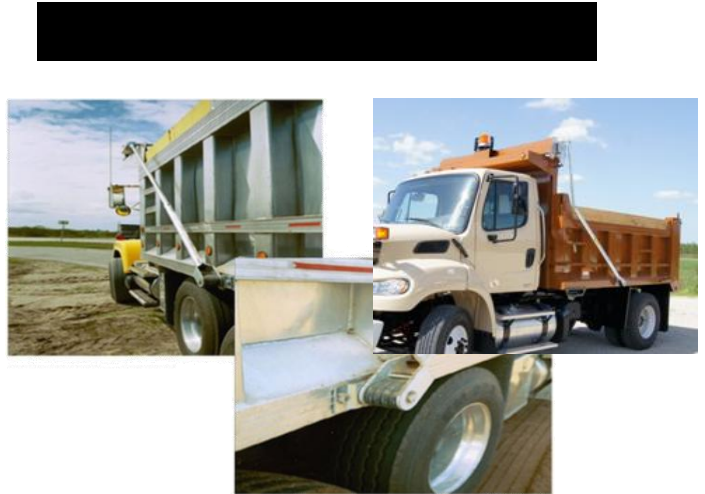

We appreciate your purchase of a tarp system. We promise that all our tarp systems are built from the highest quality material available, therefore we can also vow to stand behind the quality of our product.

WARNING:

- Never operate tarp system under power lines, this may cause injury due to electrocution.
- Never operate tarp system while moving.

CAUTION:

- Read through instructions for entire system and follow directions thoroughly to ensure the system functions properly.

TOOLS REQUIRED:

- Ratchet
- 3/8", 1/2", 9/16", and 3/4" Sockets and Wrenches
- Pipe Wrench
- Welder– Steel and Aluminum
- Screw Driver
- Drill
- 3/8" and 1/2" Drill
- 1-1/2" Hole Saw

CONTENTS – EXTERNAL ALUMINUM & STEEL

INSTALLATION INSTRUCTIONS

INCLUDED PARTS:

* = OPTIONS

QTY	Part #	Description
Long Box		
2	T-ALA## T-SLA##	4 or 5 Spring Aluminum Lower Arm 4 or 5 Spring Steel Lower Arm
2	T-ASAWC T-SUA	Aluminum Upper Arm w/ Corner Steel Upper Arm
1	T-ACT T-SCT	Aluminum Cross Tube Steel Cross Tube
1	T-ATA103	Aluminum Tarp Axle
Small Box		
2	T-PP#SP	4 or 5 Spring Pivot Pin
8 or 10	T-STC	Spiral Torsion Springs
1	T-ABWF	Axle Bearing With Flange
2	T-ATSMB	Aluminum Tarp Spool Mounting Brackets
2	T-PTCF T-STCF	PATRIOT, Plastic Tarp Centering Stealth, Plastic Tarp Centering Flange
1	T-SS	Steel Stud Shaft
1	T-HWK	Hardware Bag for Aluminum or Steel System
*1	T-A45C	Aluminum 45 Degree Angles
Electric Components		
1	T-50:1	Tarp Motor
1	T-W8G	Roll of 8 Gauge Dual Connector Wire
1	T-RSK *T-RPS2	Rotary Switch Kit Weatherproof Reverse Polarity Super Switch
Manual Components		
1	T-SB14	Sprocket Bar, 14"
1	T-C#40	#40 Crank Chain
1	T-CBGL	Ground Level Crank Box

CONTENTS OF THE TARP SPOOL

INSTALLATION INSTRUCTIONS

SPOOL ASSEMBLY WITH OPTIONAL WIND DEFLECTOR

- 1 - 103" ALLMINUM WIND DEFLECTOR
- 2 - ALUMINUM TARP SPOOL MOUNTING BRACKETS
- 3 - TARP MOTOR
- 4 - 3/4" BEARING WITH FLANGE
- 5 - 103" ALUMINUM TARP AXLE
- 6 - 5" X 3/4" STUD SHAFT
- 7 - RUBBER BUMPER
- 8 - 5/16 X 3/4" BOLT
- 9 - 5/16 NYLON NUT
- 10 - 5/16 X 2 1/4" BOLT
- 11 - 1/2 X 1" BOLT
- 12 - 1/2" NUT
- 13 - 5/16 X 3/4" BOLT
- 17 - 3/8 X 1 1/2" SELF TAPPING BOLTS

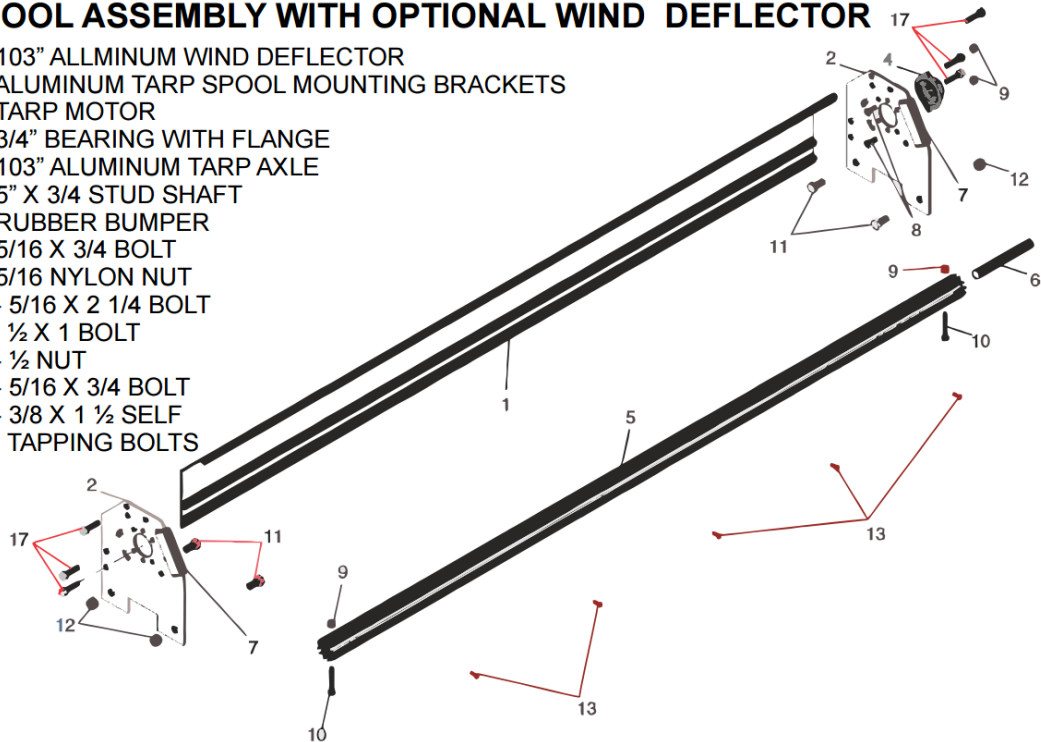

SPOOL ASSEMBLY WITH OPTION HOUSING

- 1 - 98" OR 96" TARP HOUSING
- 3 - 103" ALUMINUM TARP AXLE
- 4 - 3/4" AXLE BEARING WITH FLANGES
- 5 - 5" X 3/4" STUD SHAFT
- 7 - ALUMINUM HOUSING SUPPORT BRACES
- 8 - 5/16 X 2 1/4" BOLT
- 9 - 5/16 X 2 1/4" BOLT
- 10 - 5/16 NUT
- 13 - 5/16 X 3/4" BOLT
- 14 - 5/8 X 1 1/2" BOLT
- 15 - 5/8" FLAT WASHER
- 16 - 5/8" NUT
- 18 - 5/16 X 3/4" BOLT

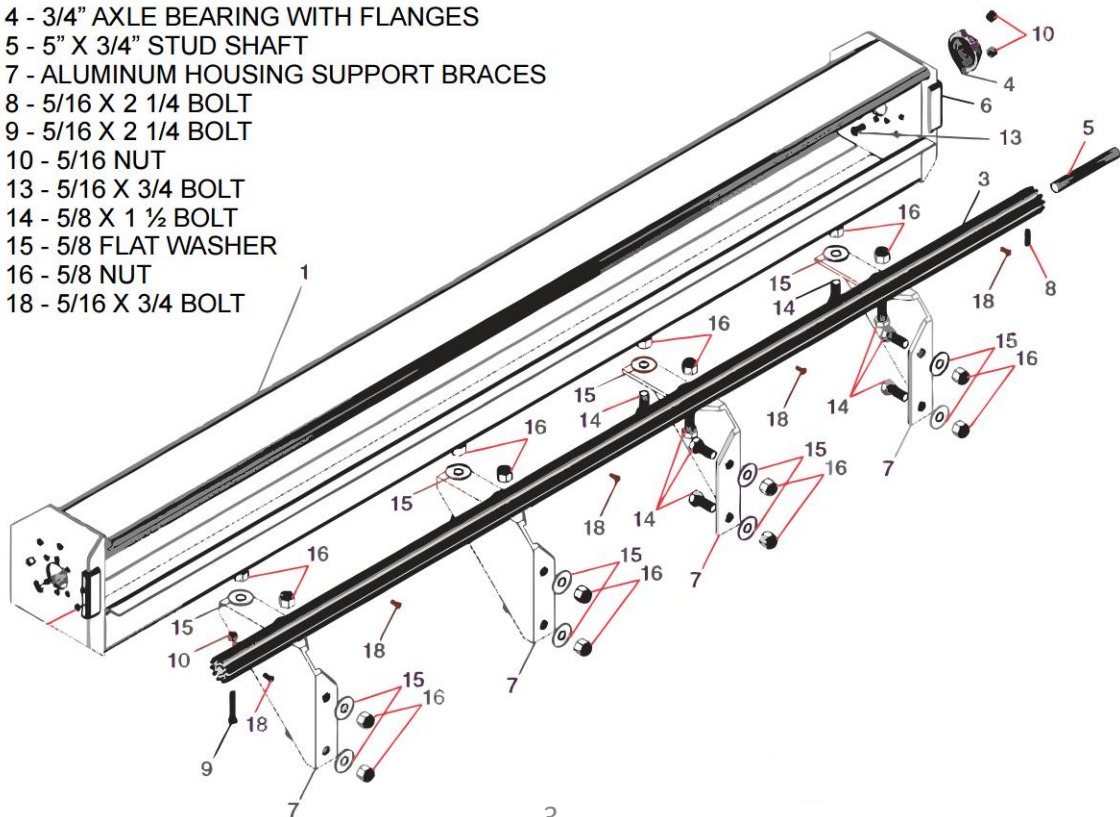

BEGINNING YOUR INSTALLATION

INSTALLATION INSTRUCTIONS

STEP 1: CHOOSING THE MOUNTING LOCATION OF THE TARP SPOOL KIT

The Tarp Spool Kit (T-SKMP) and Tarp motor should be mounted on top of the cab guard and as far forward as possible to avoid damage by loaders. **Note: If it is mounted too far forward, it may interfere with the truck doors.** (See [Figure 1](#)) The ideal location is determined by placement of the pivot arms from the Tarp Spool Kit to the pivot point on the dump body. See the Pivot Mounting instructions for determining the pivot point on dump or trailer body.

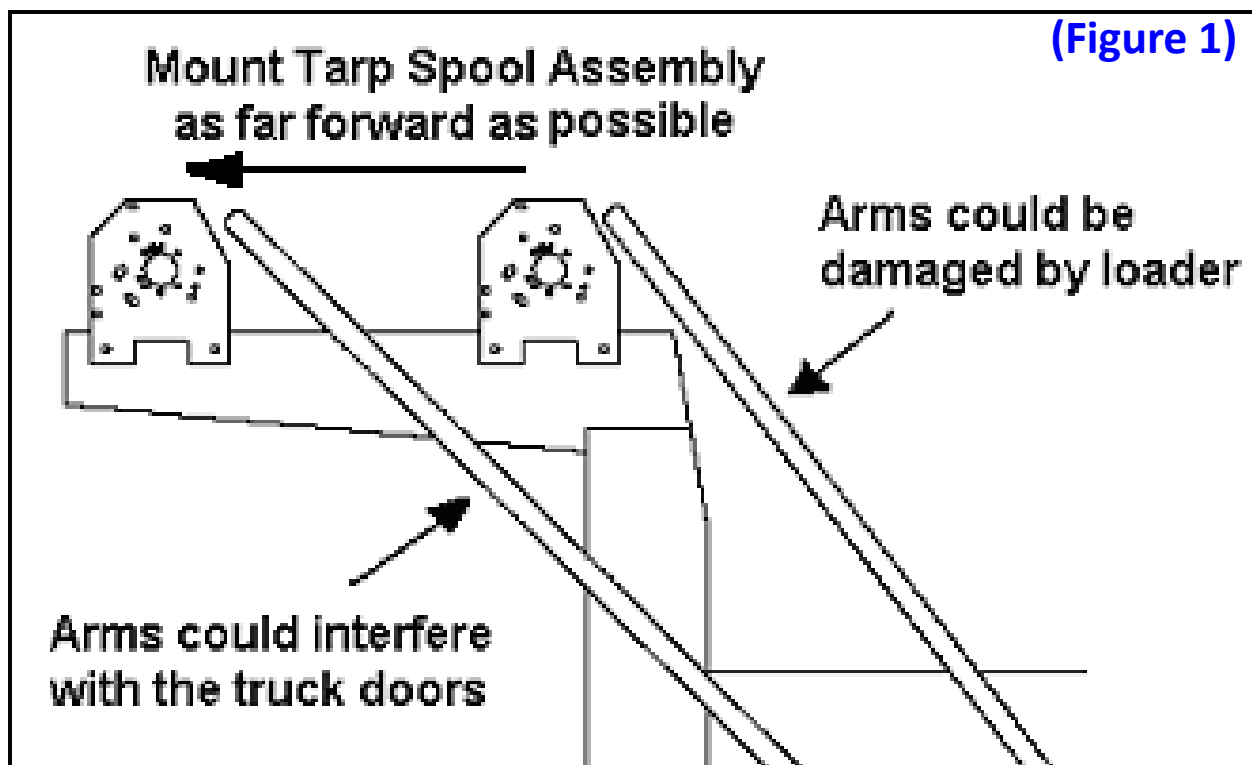

Exceptions: Trucks with vertical stacks may be in the way of the pivot arms if the Tarp Spool Kit (T-SKMP) and motor were mounted ahead of the stack(s). You can either realign or shorten the stack(s) to solve this problem. Otherwise, the Tarp Spool Kit and motor should be mounted towards the rear of the stacks. If there is no room to mount the Tarp Spool Kit and motor towards the rear, they will need to be mounted on top of the side board pockets to the front of the body.

ELECTRIC – TARP SPOOL INSTALLATION

INSTALLATION INSTRUCTIONS

STEP 2: INSTALLING THE MOUNTING BRACKETS

Once you have determined your mounting location, you may either install the included Tarp Spool Mounting Brackets (T-ATSMB) using the enclosed hardware or use the brackets as a template to drill the necessary holes into the cab guard sides or other secure location.

Note: If you use the brackets as template, please ensure that there is enough clearance between the tarp spool and the cab guard to roll-up the entire tarp.

STEP 3: MOUNTING THE TARP MOTOR AND TARP SPOOL

Mount the motor to the Tarp Spool Mounting Brackets (T-ATSMB) or cab guard. Measure from inside of one bracket to the inside of the other. Cut the Aluminum Tarp Axle (T-ATA103) on the end without the pre-drilled hole 1" shorter than its length. Drill a 5/16" cross hole through the Tarp Axle, 3/4" in from the end that was just cut off. Start the hole in one of the round bottomed slots, not one of the threaded slots. Slide one end of the Tarp Axle over the motor output shaft and secure with a 5/16" carriage bolt, washer, and nut. Slide the Stud Shaft (T-SS) through the Axle Bearing (T-ABWF) into the Tarp Axle. Line up the holes in the Tarp Axle to the hole in the Stud Shaft and secure with 5/16" carriage bolt, washer, and nut.

***STEP 4: INSTALLING THE OPTIONAL WIND DEFLECTOR**

Cut the Aluminum Wind Deflector (T-AWD) to the proper length and attach it to the Tarp Spool Mounting Brackets (T-ATSMB) using the included six (6) each self threading bolts. (See [Picture](#))

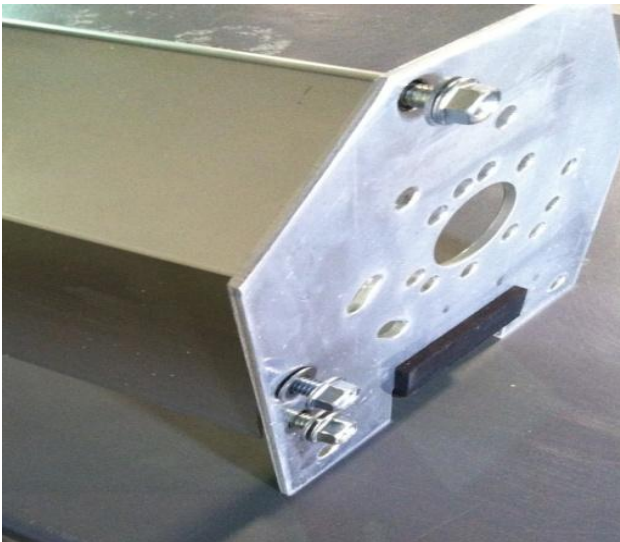

Option Wind Deflector With Aluminum Mounting Bracket

MANUAL – TARP SPOOL INSTALLATION

INSTALLATION INSTRUCTIONS

STEP 2: INSTALLING THE MOUNTING BRACKETS

Once you have determined your mounting location, you may either install the included Tarp Spool Mounting Brackets (T-ATSMB) using the enclosed hardware or use the brackets as a template to drill the necessary holes into the cab guard sides or other secure location.

Note: If you use the brackets as template, please ensure that there is enough clearance between the tarp spool and the cab guard to roll-up the entire tarp.

STEP 3: MOUNTING THE SPROCKET BAR AND TARP SPOOL

Mount the Tarp Spool Mounting Brackets (T-ATSMB). Measure from inside of one bracket to the inside of the other. Cut the Aluminum Tarp Axle (T-ATA103) on the end without the pre-drilled hole 1" shorter than its length. Drill a 5/16" cross hole through the Aluminum Tarp Axle, 3/4" in from the end that was just cut off. Start the hole in one of the round bottomed slots, not one of the threaded slots. Slide one end of the tarp axle over the sprocket bar output shaft and secure with a 5/16" carriage bolt, washer, and nut. Slide the Stud Shaft (T-SS) through the Axle Bearing (T-ABWF) into the tarp axle. Line up the holes in the tarp axle to the hole in the Stud Shaft and secure with 5/16" carriage bolt, washer, and nut.

***STEP 4: INSTALLING THE OPTIONAL WIND DEFLECTOR**

Cut the Aluminum Wind Deflector (T-AWD) to the proper length and attach it to the Tarp Spool Mounting Brackets (T-ATSMB) using the included six (6) each self threading bolts. (See [Picture](#))

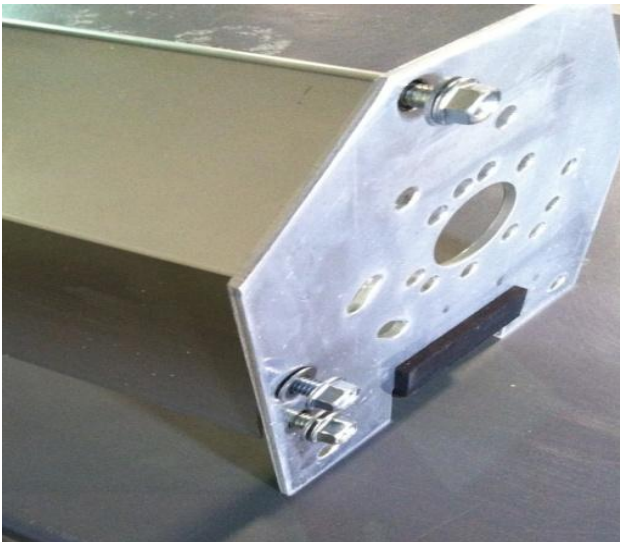

Option Wind Deflector With Aluminum Mounting Bracket

ELECTRIC – TARP MOTOR INSTALLATION

INSTALLATION INSTRUCTIONS

STEP 5: WIRING THE TARP MOTOR

The motor must be wired with the provided 6 / 8 Gauge Wire. Use of smaller wire will cause your tarp system to operate slowly and possibly overheat. **Suggestion: Running ¾" EMT conduit down the front of the body and back along the frame rail provides a safe place to run the wires as well as adding a clean look to your system installation.**

1. Mount the included switch bracket in a convenient location making sure that nothing will fall or rest against the bracket that could hold the switch in the "On" position or prevent the circuit breaker from popping. Either situation could damage the motor and the motor **will not be covered under warranty.**
2. Connect the switch, circuit breaker, and indicator light in the bracket as shown in **Figure 2 and 3** [full size images in following page] using the included terminals and jumper wire.
3. Unroll the included 6 / 8 gauge wire. Run the wire down the front of the body from the tarp motor, back along the bottom of the box, around the hinge (leaving enough slack to avoid binding or pinching during the operation of the lift) and into the cab where the switch is mounted. For tractor-trailer or lead-pup combinations, a plug set rated to 50 amps or higher should be used between the truck and the trailer(s).
4. Cut off the extra lengths of wire, leaving enough to easily connect to the switch. Set aside one of the pieces of left-over wire to later run from the cab to the positive (+) post of the battery or starter. **WARNING: DO NOT CONNECT AT THIS TIME!** Run another piece of wire from the cab to a ground screw on the firewall or other suitable grounding location using the included terminal.
5. Connect the wires leading from the switch to the motor using from the cab to the ground terminal of the battery and connect using the included terminal.
6. Connect the positive wire to the battery terminal marked (+) and check to see that the system is operating as indicated on the switch bracket. To wind-up the tarp, the tarp roller bar should spin counter-clockwise viewing it from the driver's side of the cab. If not, swap the two wires connected to the motor. If the roller bar rotates clockwise, any debris on the tarp will be rolled up in it and possibly cause damage.

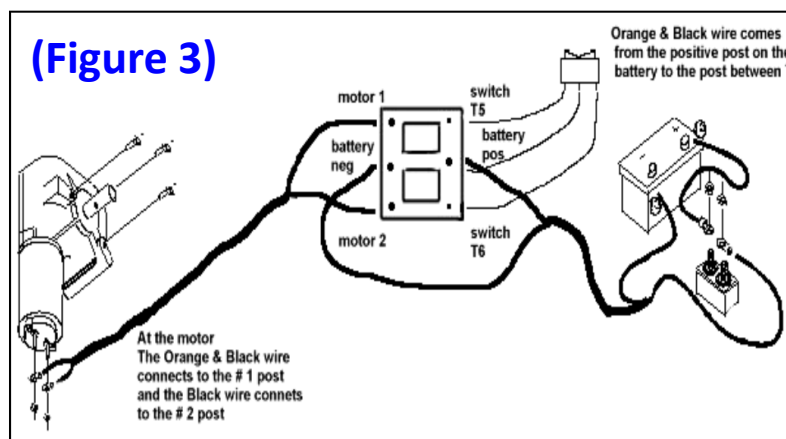
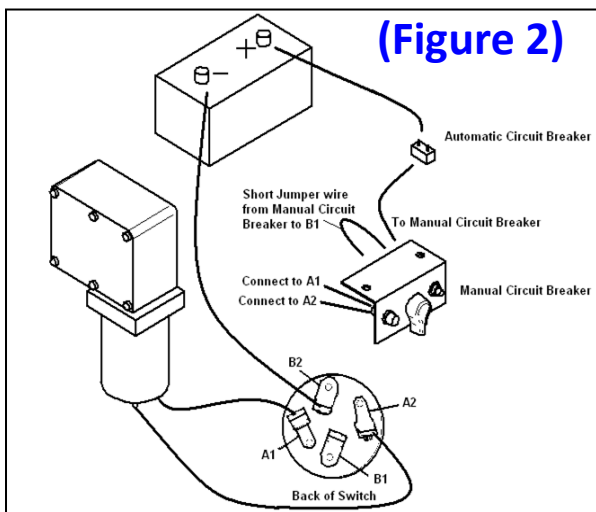

OPTIONAL SOLENOID SWITCH KIT

INSTALLATION INSTRUCTIONS

SOLENOID SWITCH KIT OPTIONAL

(Figure 3B)

Connect MTR.1 and MTR.3 studs to motor leads. Connect T2 to -12VDC (ground). Connect T4 to +12VDC with appropriate circuit breaker in-line

Connect output 1 of control switch to T5 (12V+) and output 2 of control switch to T6 (12V+). The common terminal of control switch (middle terminal) should be connected to +12VDC.

Large studs torque: 40 in-lbs max.
Small studs torque: 12 in-lbs max.

Control switch must be a spot switch. To protect your motor, don't ever use this device without a circuit breaker in-line with T4.

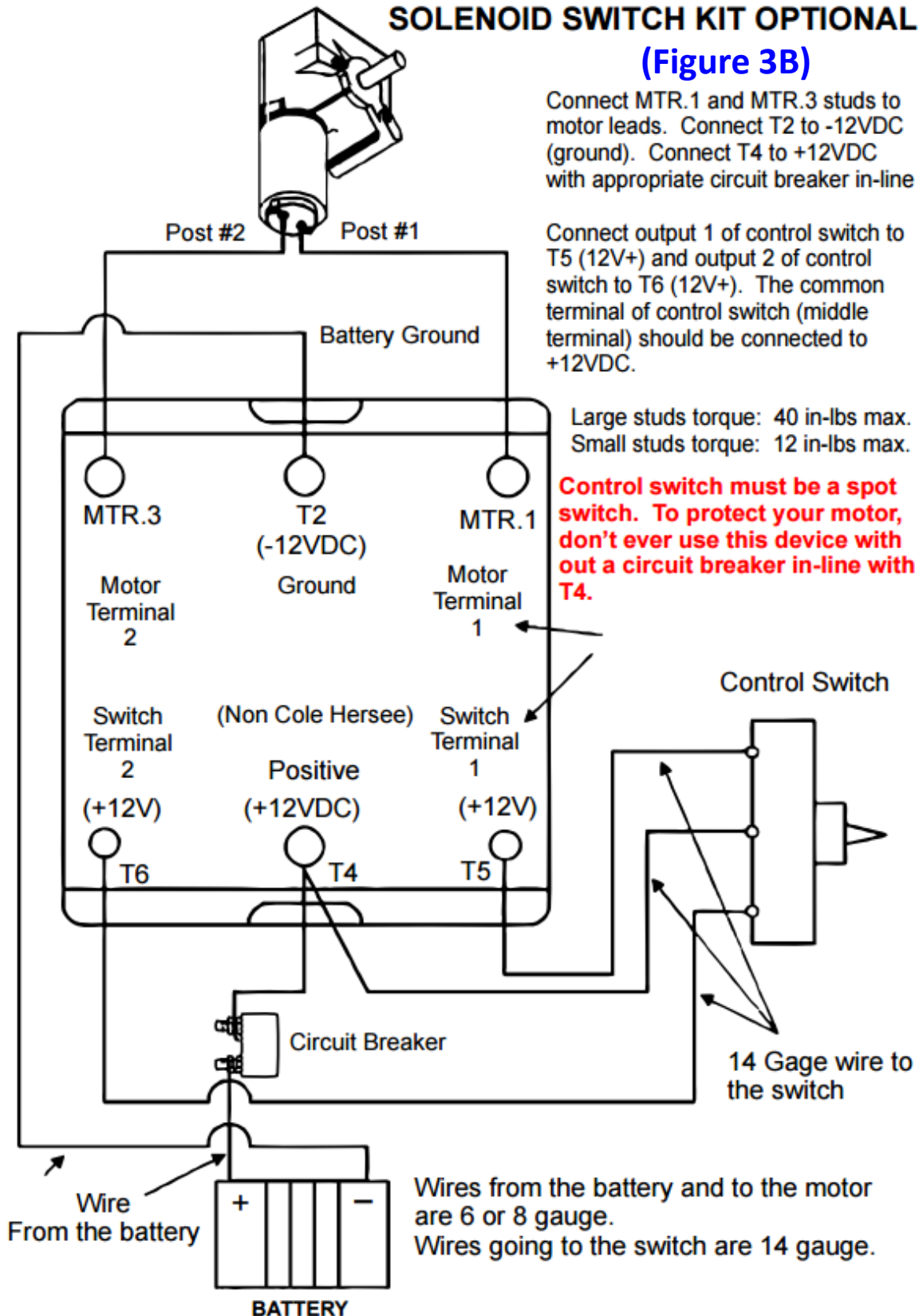

MANUAL – CRANK ASSEMBLY INSTALLATION

INSTALLATION INSTRUCTIONS

STEP 5: ATTACHING THE CRANK BOX AND CHAIN

1. Choose a comfortable position that the crank handle can be operated from the ground. Mark this location. **Note: The crank box does not need to be directly below the sprocket.**
2. Wrap the #40 chain over the sprocket of the tarp spool and pull it through the center point of the area you marked as the location for the crank box. Trace a 6" line along the edge of the chain from the center point of the crank box toward the tarp spool.
3. Place the crank box back over the center point and angle it so the line is exiting the top of the box. **Note: If the box cannot be mounted because it extends past the edge of the box, repeat step 5-1 and 5-2.** Drill and mount the crank box.
4. Release the master link of the #40 chain, adjust the length of the chain, install the chain on both the crank box and the spool's sprocket bar.
5. Install the optional chain guard at this time.

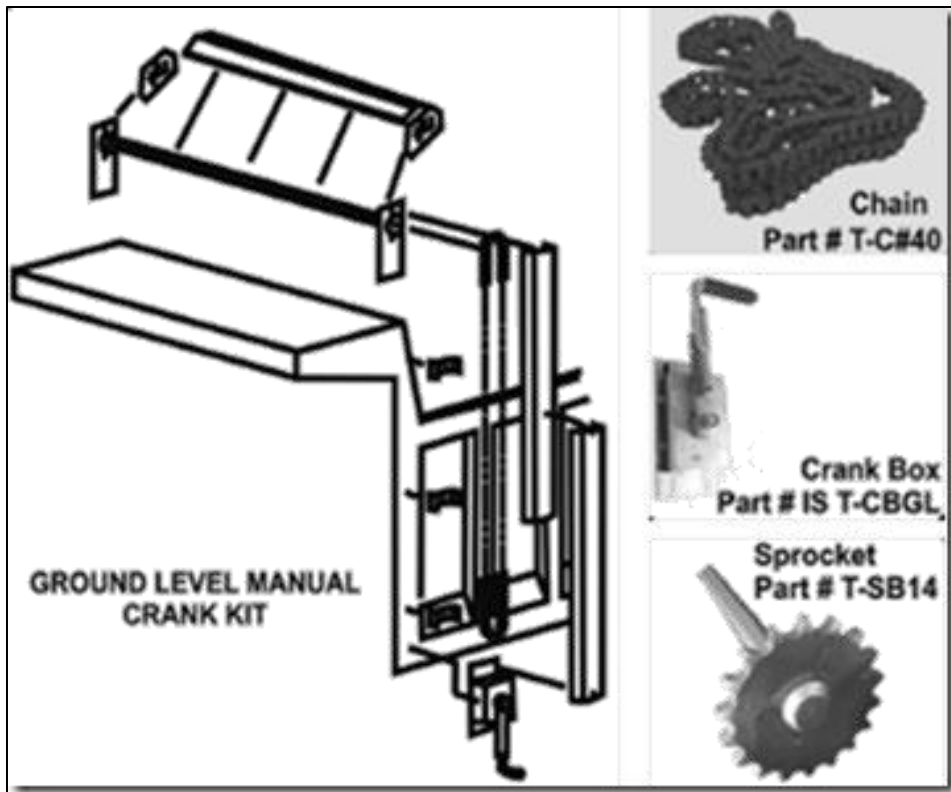

PIVOT POINT MEASUREMENT

INSTALLATION INSTRUCTIONS

STEP 6: POSITIONING THE PIVOT PINS

1. Measure your dump body from **Point A** to **Point B**. (See **Figure 4**) Divide that number by 2 and make a mark at the top of the bed for **Point C**.
2. Measure from **Point B** to **Point C**.
3. Bring measurement from **Point C** down to the bottom of your bed. Starting from **Point B2**, Measure out toward the cab until you reach the same measurement from step 2. This will be **Point C2**. (Your Pivot Point).
4. Repeat steps 1 through 3 on other side of bed to make sure pivot points are equal.
5. Before moving on to step 6, double check your measurements by measuring from **Point A** (Center Point of Motor Shaft) to **Point C2**. Next, measure from **Point B** to **Point C2**. Both measurements should be the same. This will be center point of pivot pin.
6. Hold pivot pin on center mark and mark holes for pivot pin placement (**Figure 4a**)

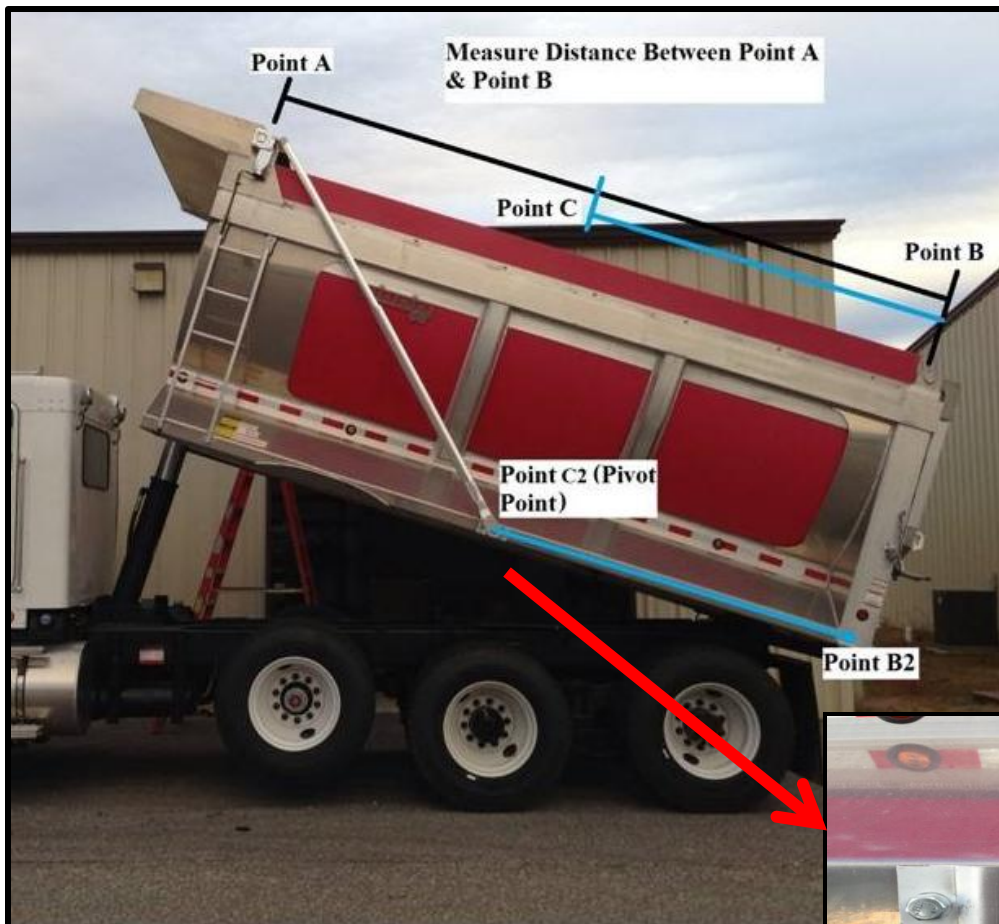

(Figure 4)



(Figure 4a)

ALUMINUM & STEEL – EXTERNAL MOUNT

INSTALLATION INSTRUCTIONS

STEP 6 (CONTINUED): POSITIONING THE PIVOT PINS

7. Bolt the pivots pins to the box using the 5/8 x 1 ½ bolts included in hardware bag. (The head of the bolt must be on the outside, and the washer and nut on the inside). **Note: The pivots are directional** (See [Figure 5](#)) below to determine which is the driver and passenger side pivots).
8. To load the Spiral Torsion Springs (T-STs), rotate the pivots so that the hooks on the springs will clip over the pin inside the spring guard, as shown in [Figure 5](#) below.

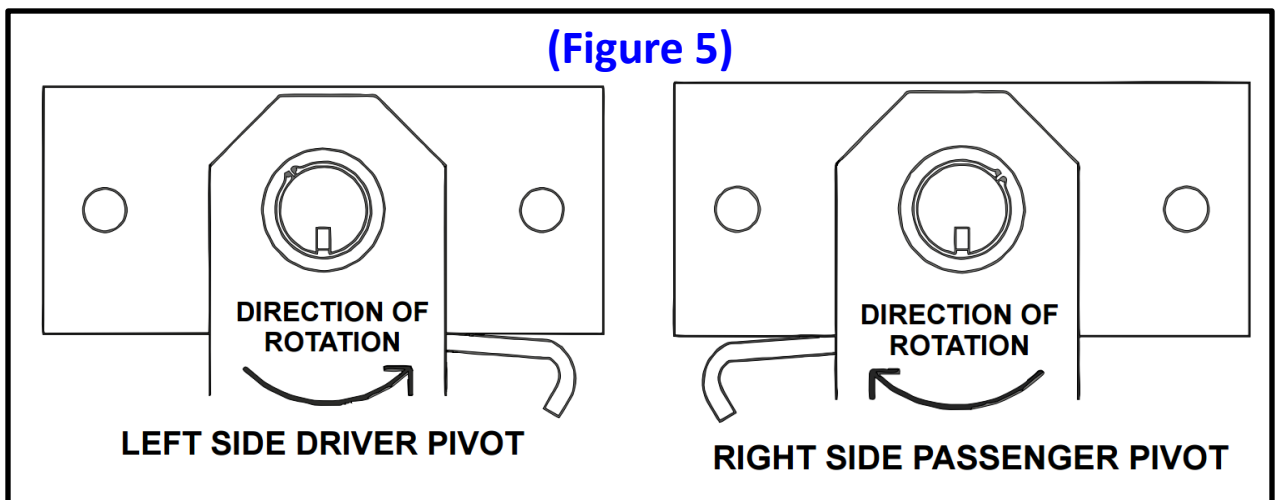

STEP 7: INSTALLING THE TARP BOW

1. Hold one of the upper arms (tube w/corner) up to the side of the dump body with the corner against the center of the Tarp Spool or housing opening and with the end of the tube going past the pivot point. If the bow is in the way of the door, or if it will be in the way of a loader, then the bows should be offset. The bows can be offset by calling your dealer and ordering a 30° or 45° (T-A45C) bow insert. If you have any questions regarding the offset of the bows, please contact your local dealer.
2. Rotate the pivots around toward the front of the truck and back so that the pin inside the spring guard ends up resting on top of the springs. This will simplify the rest of the installation because the pivots may now be moved without loading the springs. The pivots should now be pointing toward the rear of the body.
3. Slide one of the upper arms into the aluminum / steel pivot arm. Adjust the arm length until the corner rests on the desired landing point at the back of the dump body. (**Point B** from the previous Pivot Installation). If the arm is too long, cut both arms to the correct length. Leave about 2 feet of tube sticking into the pivot tube and make sure that both arms are cut to the same length.
4. Slide both upper arms into the aluminum / steel pivot arms (make sure that both arms end up the same length) and lightly tighten the two bolts that hold each upper arm in the pivots. Final tightening will be done later.

ALUMINUM & STEEL – EXTERNAL MOUNT

INSTALLATION INSTRUCTIONS

STEP 7 (CONTINUED): INSTALLING THE TARP BOW

5. Slide the ends of the rear cross tube (w/o corner) over the upper arm corners.
6. Line up the hole in each end of the rear cross tube with the holes in the upper arms and lightly fasten the two included 5/16" x 1 3/4" bolts and 5/16" Nylon nuts.
7. Swing the assembled tarp bow forward until it rests on the tarp spool or housing assembly. The bow should be resting in the center of the tarp spool or housing assembly opening. If the bow is not landing in the center of the opening, loosen the 4 bolts that hold the upper arms in the pivots and adjust both bows. Lightly re tighten the bolts.
8. Swing the tarp bow back to the rear of the dump body and check the landing position. If it appears that the bow will interfere with the operation of the tailgate, the pivot point may need to be moved.
9. Check for binding or rubbing of the tarp bows against the sides of the dump body. Check both sides of the body, and adjust the pivot brackets or bows as necessary for clearance.
10. Mark both tarp bows upper arms where they slide into the pivot tubes. This will allow you to reassemble the bows without measuring again.

Aluminum Lower Arm



Steel Lower Arm

11. Remove the rear cross tube and upper arms so that you may load the pivot springs again.
12. Rotate both pivots forward and down so that they are left hanging straight down.
13. Pre-load the pivot springs by rotating the pivots one at a time toward the front of the body, down and around, and up until you are able to reinstall the tarp bow upper arms. You may need to lift bed to make clearance for the arms. Slide the upper arms down into the lower tube to the mark made in Step 10 and tighten the bolts that hold them in place. Make sure that the hook ends of the springs have clipped over the pin in the spring guard.
14. Set the rear cross tube across the back of the body, but do not re-install until you have installed your tarp.

ALUMINUM TARP AXLE – TARP INSTALLATION

INSTALLATION INSTRUCTIONS

STEP 8: INSTALLING YOUR TARP

1. Line the five (5) grommets on the front edge of the tarp up with one of the threaded grooves in the front of the aluminum tarp axle.
2. Attach the tarp to the front axle with 5/16" x 5/8" button head bolts.
3. Slide the rear cross bar through the pocket in the back of the tarp and center.
4. Slide (1) plastic tarp centering flange included in the system kit on each end of the rear cross bar and then reattach the cross bar to the upper arms.
5. Slide the inside set of plastic tarp flanges up against the tarp and tighten the set screws securely. These flanges will help keep the tarp centered on the rear cross bar.
6. Adjust and secure the set of outside plastic flanges near the upper arms so that they will act as bumpers between the rear cross bar and the dump body and/or tarp spool assembly.

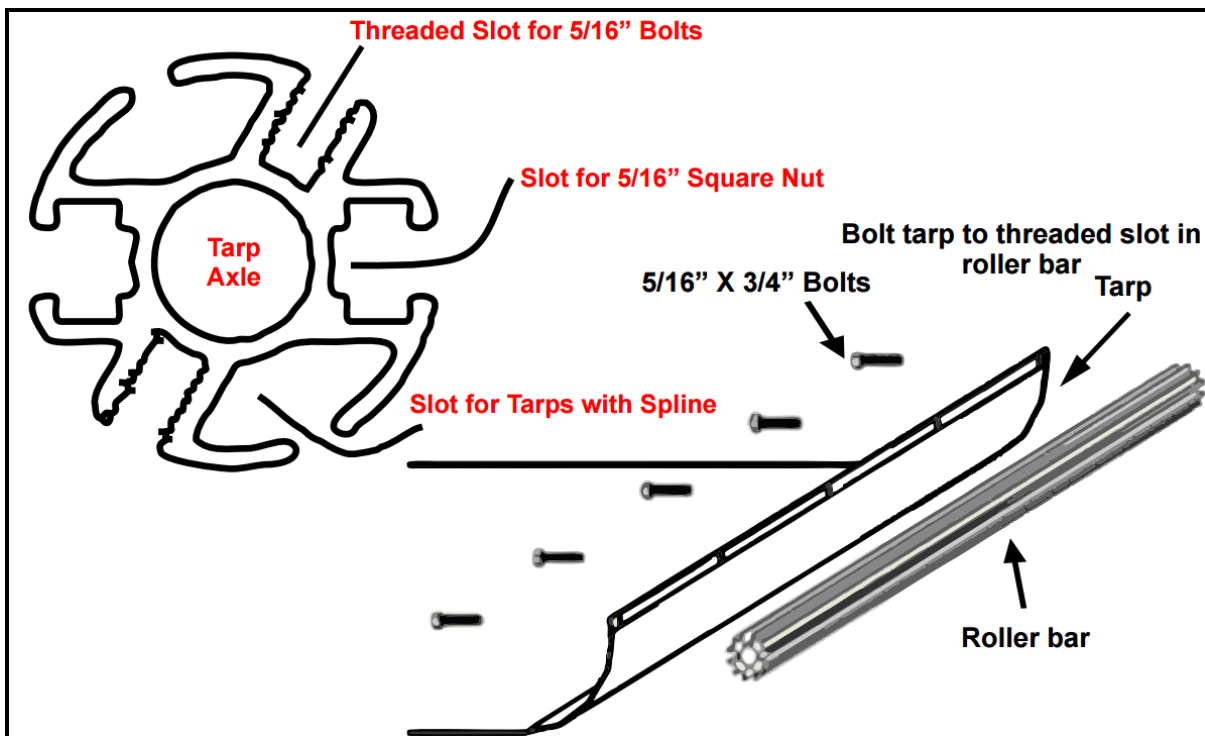

Congratulations on installing your new tarp system. We appreciate your business!

ALUMINUM – EXTERNAL MOUNT

INSTALLATION INSTRUCTIONS

DIAGRAMS: COMPLETE ARM SETS

Aluminum Arm Set

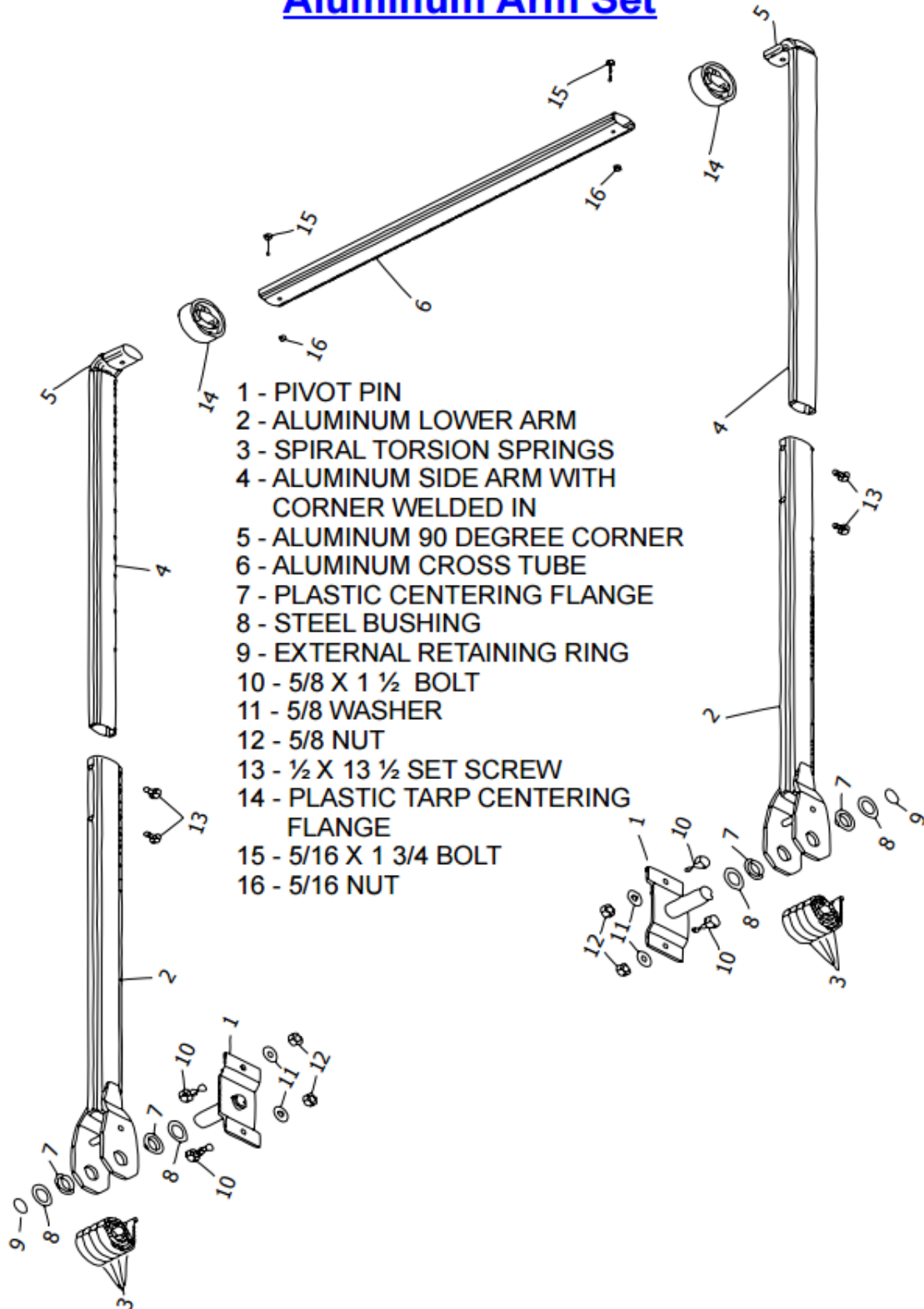

STEEL – EXTERNAL MOUNT

INSTALLATION INSTRUCTIONS

DIAGRAMS: COMPLETE ARM SETS

Steel Arm Set

