

PLEASE RETAIN

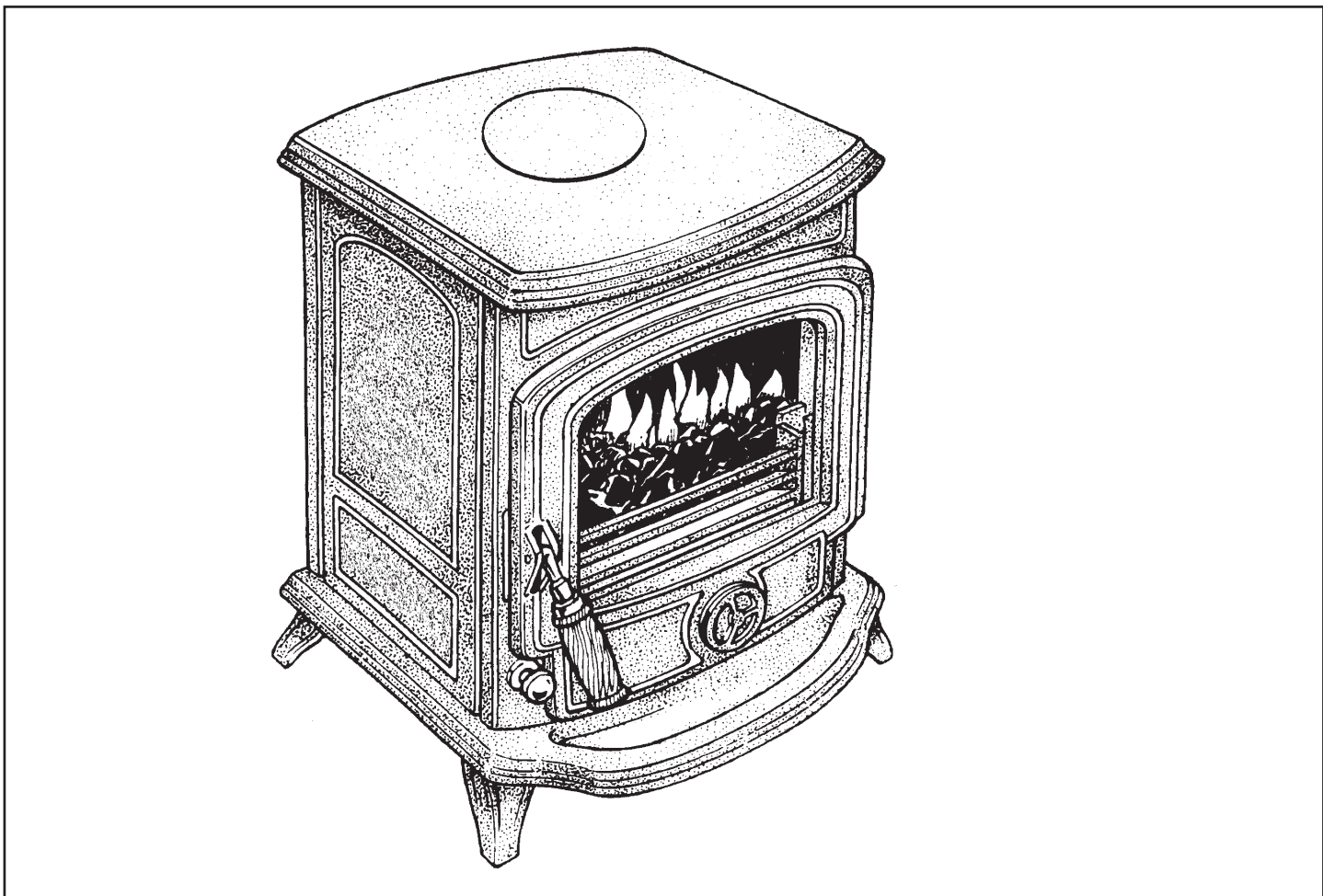

Oisín Solid Fuel Stove



This appliance is hot while in operation and retains its heat for a long period of time after use. Children, aged or infirm persons should be supervised at all times and should not be allowed to touch the hot working surfaces while in use or until the appliance has thoroughly cooled.

When using the boiler stove in situations where children, aged and/or infirm persons are present a fireguard must be used to prevent accidental contact with the stove. The fireguard should be manufactured in accordance with BS 8423:2010.

INSTALLATION AND OPERATING INSTRUCTIONS

TABLE OF CONTENTS

	PAGE NO.
1. Stanley Solid Fuel Stove Warranty	4
2. Installation Checklist	5
3. Important Operation/ Maintenance Notes	6
4. Installation & Operating Instructions	7
5. General	7
6. Pre-Installation Assembly	7
7. Flues	7
8. Chimney	8
9. Flue Exit - Top and Rear	8
10. Down Draughts	9
11. Ventilation and Combustion Air Regulations	9
12. External Ducted Air	10
13. Heat Recovery Ventilation (HRV)	10
14. Location	11
15. Clearance to Combustibles	11
16. Floor Protection	11
17. Plumbing	12
18. Water Pipe Locations	12
19. DHW System (Domestic Hot Water)	12
20. Safety Valve	13
21. Direct Domestic Cylinder	13
22. Indirect Domestic Cylinder	13
23. Pipe Thermostat	13
24. Regulations	13
25. Gravity Circuit	13
26. Stove Dimensions	14
27. Commissioning and Handover	14
28. Operation	14
29. Air Controls	14
30. Recommended Fuels	14
31. Technical Data	15
32. Lighting	15
33. User Instructions	15
34. Refuelling	16
35. Slow Burning	16
36. De-Ashing	16
37. Disposal of Ashes	16
38. Monthly Maintenance	16

TABLE OF CONTENTS

	PAGE NO.
39. Periodic Maintenance	16
40. Chimney Cleaning	16
41. Glass Cleaning	17
42. Vitreous Enamel Cleaning	17
43. Cleaning a Matt Black/ Senotherm Stove	17
44. Change Rope Seals	17
45. Prolonged Periods of Non Use	17
46. Fire Safety	18
47. Glass Replacement	18
48. CO Alarm	18
49. Exploded View	19



STANLEY SOLID FUEL STOVE WARRANTY

CONDITIONS OF WARRANTY

Your Stanley Solid Fuel Stove is guaranteed against any part that fails (under normal operating conditions) as detailed in the following table with timelines specified from the date of installation of the appliance. If the unit is not installed within six months of date of purchase, the warranty will commence six months from the date of purchase.

Warranty Period	Parts Covered (Parts & Labour unless Stated)
Up to 1 Year	<ul style="list-style-type: none">• Refractory materials (supply only)• Rope seals, glass seals and cement seals.• Surface Finish on Seno models.• Grates and fire bars.• Ceramic glass is covered for Thermal breakage (supply only).• Rust (if reported before installation)• Aesthetic Damage (provided reported on date of receipt)
Up to 5 Years	<ul style="list-style-type: none">• All external castings & enamel finishes (excluding impact damage or damage caused by overfiring). Pictures of damage must be submitted to WS Service Department.
Up to 3 Years	<ul style="list-style-type: none">• Boiler - A Leaking Boiler Report must be conducted by an Authorised Stanley Service Engineer and submitted to WS Service Department for review.

All warranty claims must be reported to the Waterford Stanley Service Department and must be submitted with the product serial number (located on the front casting), date of purchase, proof of purchase (if requested) and details of the specific nature of the problem.

The warranty is given only to the original consumer/purchaser only and is non-transferable. The appliance must be installed by a suitable qualified person and installed as per the requirements of the manual. Failure to comply with the Installation requirements or Building Regulations will void your warranty. Waterford Stanley reserve the right to replace any part due to manufacturing defect that fails within the warranty period under the terms of the warranty. The unit must be used for normal domestic purposes only and in accordance with manufacturer's operation instructions.

LIMITS OF LIABILITY

The warranty does not cover:

- * Special, incidental or consequential damages, injury to persons or Property, or any other consequential loss.
- * Any issue caused by negligence, misuse, abuse or circumstances beyond Waterford Stanley's control.
- * Any issue with wear and tear, modification, alteration, or servicing by anyone other than an authorized service engineer.
- * Installation and operational related problems such as draught related issues external to the stove, inadequate venting or ventilation, excessive flue offsets, negative air pressure caused by insufficient burning of improper fuel.
- * Damage caused to the unit while in transit.
- * Enamel discolouration due to over firing, enamel damage caused by impact, damage to baffles caused by over firing and fading of surface finish on casting.
- * Stress fractures on bricks.
- * Rust on cast iron parts unless reported prior to unit being installed.
- * Aesthetic damage, rust & missing parts on units purchased off display.

Note: Adequate clearance must be maintained around the appliance to ensure the ease of part removal in the possible event of their damage/failure. Waterford Stanley are not responsible for any costs incurred in the removal of items installed in the vicinity of the appliance that have to be moved to facilitate a part replacement.

INSTALLATION CHECK LIST

Tick

Flue System

1. Minimum Flue Height of 4.6 metres (15 feet).
2. Appliance should be connected to a minimum of 1.8 metres (6 feet) of 150mm (6") flue pipe.
3. The horizontal flue run should not exceed 150mm (6")
4. All flue pipework passing through walls must be sleeved & adequately insulated in line with current Building Regulations.
5. Appliance should be connected to a chimney of less than 200mm (8") in diameter (otherwise the chimney must be lined with a 6" flue liner).
6. The chimney/ flue termination must be located in accordance with building regulations part J.
7. The chimney serving this appliance should not serve any other appliance.
8. Access should be provided to the chimney serving the appliance to allow for cleaning.
9. It is a requirement by Building Regulations to have a carbon monoxide alarm fitted to any room with a solid fuel appliance.

Location

10. Clearance to combustible materials must be adhered to as described in the Clearance to Combustible section.
11. The stove must be installed on a floor protector that covers the area under the stove and extends 18" to the front & 8" to the sides and back.
12. Clearance must be maintained to allow for maintenance and part replacement.

Ventilation & Combustion Air Requirements

13. The room in which the appliance is located should have an air vent of adequate size to support correct combustion (see Ventilation & Combustion Air Requirement Section for specific details).
14. The stove must not be installed in the same room as an extractor fan.

Plumbing and Electrical Requirements

15. All plumbing and electrical work associated with the appliance must be conducted in accordance with current Building Regulations, Maintenance Instructions and Best Practice Guidelines.



IMPORTANT OPERATION / MAINTENANCE NOTES

Now that your Stanley Solid Fuel Stove is installed and no doubt you are looking forward to many comforts it will provide, we would like to give you some tips on how to get the best results from your stove.

1. We would like if you could take some time to read the operating instructions/hints, which we are confident, will be of great benefit to you.
2. Do not burn fuel with a high moisture content, such as a damp peat or unseasoned timber. This will only result in a build up of tar in the stove and in the chimney.

FUEL CALORIFIC VALUES - SOLID FUELS		
Anthracite 25-50mm	C.V.: 8.2kW/Kg	14,000 BTUs/lb
House Coal 25-75mm	C.V.: 7.2kW/Kg	12,000 BTUs/lb
Timber - Firebox size	C.V.: 5.0kW/Kg	8,600 BTUs/lb
Peat Briquettes	C.V.: 4.8kW/Kg	8,300 BTUs/lb

3. **IMPORTANT:** The first few fires should be relatively small to permit the refractory to set properly and season the stove. During these firings it is recommended to ventilate the room as an unpleasant (not toxic) odour may be emitted as the paint is completing curement.
4. **Inspect the flue-ways of the stove weekly and ensure that there are no blockages. Check flue ways before lighting especially after a shut down period. Please see chimney cleaning section.**
5. Before loading fresh fuel into the firebox, riddle fully to remove all ashes. This will allow better and cleaner burning. See Re-Fuelling section.
6. Never allow a build up of ashes in the ash pan, as this will cause the grate to burn out prematurely. Empty the ashpan when refuelling.
7. Avoid slow burning of damp or unseasoned fuel as this will result in tarring flue ways and chimney i.e. peat or timber.
8. Allow adequate air ventilation to ensure plenty of air for combustion.
9. Do not burn rubbish/household plastic.
10. Do not operate the stove with the ash-door open as this will over heat the unit causing unnecessary damage.
11. Clean the chimney at least twice a year.
12. Burning soft fuels such as timber and peat will stain the glass. Regular cleaning will prevent permanent staining. Clean with soapy water when cool.
13. Keep all combustible materials a safe distance away from unit, please see section for clearances to combustibles.
14. Never use aerosol spray near the appliance when it is in operation.
15. For safety reasons never leave children or the elderly unaccompanied while stove is in use. Use a fire guard.
16. Avoid contact with the appliance when in use as stove reaches very high operating temperatures.
17. This appliance should be regularly maintained by a competent service engineer.

THE OISIN SOLID FUEL NON BOILER STOVE INSTALLATION & OPERATING INSTRUCTIONS

GENERAL

When installing, operating and maintaining your Oisin Stove respect basic standards of fire safety. Read these instructions carefully before commencing the installation. Failure to do so may result in damage to persons and property. Consult your local Municipal office and your insurance representative to determine what regulations are in force. Save these instructions for future reference.

Please note that it is a legal requirement under England & Wales Building Regulations that the installation of the stove is either carried out under Local Authority Building Control approval or is installed by a Competent Person registered with a Government approved Competent Persons Scheme. HETAS Ltd operate such a scheme and a listing of their Registered Competent Persons can be found on their website at www.hetas.co.uk.

Special care must be taken when installing the stove such that the requirements of the Health & Safety at Work Act are met.

Handling

Adequate facilities must be available for loading, unloading and site handling.

Fire Cement

Some types of fire cement are caustic and should not be allowed to come into contact with the skin. In case of contact with the skin wash immediately with plenty of water.

Asbestos

This stove contains no asbestos. If there is a possibility of disturbing any asbestos in the course of installation then please seek guidance and use appropriate protective equipment.

Metal Parts

When installing or servicing this stove care should be taken to avoid the possibility of personal injury.

“IMPORTANT WARNING”

This stove must not be installed into a chimney that serves any other heating appliance.

The complete installation must be done in accordance with current Standards and Local Codes. It should be noted that the requirements and these publications may be superseded during the life of this manual.

Please refer to the current standards, BS EN 15287-1:2007 Design, Installation and Commissioning of chimneys.

PRE-INSTALLATION ASSEMBLY

1. After removing the stove from its packaging, open the fire door and remove all contents from the ashpan.
2. Fit the fire door handle by screwing into the fire door axle (see fig. 1).
3. Remove the stove from the pallet and position it in the final installation position (see location and clearance to combustibles section).

Your Oisin stove is supplied with the following items:

- Timber Handle (Black, Majolica & Seno)
- Black Spring Handle Assembly (Cream & French Grey)
- Glove (Cream & French Grey only)
- Ashpan
- Operating Tool
- Touch-Up Paint (Enamel Only)
- Installation & Operating Manual

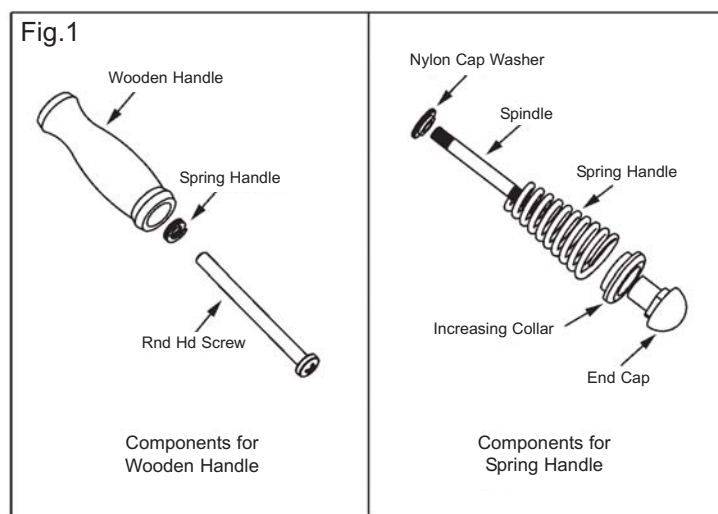

FLUES

Flues should be vertical wherever possible and where a bend is necessary, it should not make an angle of more than 45° with the vertical. Horizontal flue runs should be avoided except in the case of a back outlet from the appliance, when the length of the horizontal section should not exceed 150mm.

CHIMNEY

The Oisin is a radiant room heater and must be connected to a chimney of the proper size and type. The chimney must have a diameter of at least 150mm. Never connect to a smaller size chimney. Do not connect to a chimney serving another appliance. The stove is supplied with a 5" flue spigot, the flue installation will require a 5" to 6" increaser which must be fitted within 1.5 meters of flue outlet. Minimum chimney height 15' (4.1 meters) from floor on which stove is installed. A flue that has proved to be unsatisfactory, particularly with regard to down draught should not be used for venting this appliance until it has been examined and any faults corrected. An existing masonry chimney should be inspected and if necessary repaired by a competent mason or relined using an approved lining system. The stove must be connected to a chimney with a minimum continuous draught of 0.06 w.g. Poor draught conditions will result in poor performance.

All register plates, restrictor plates, damper etc., which could obstruct the flue at a future date should be removed before connecting this appliance. If connecting to an existing chimney with a flue diameter of more than 8" it is recommended to line the flue using a suitable stainless steel flue liner.

To minimise the wind effects, the flue termination point should be located a minimum of 1000mm from the roof measured vertically and 2300mm measured horizontally. Where this termination point does not suffice it may be necessary to extend the flue pipe so that the termination point is above the apex. (See Fig.2)

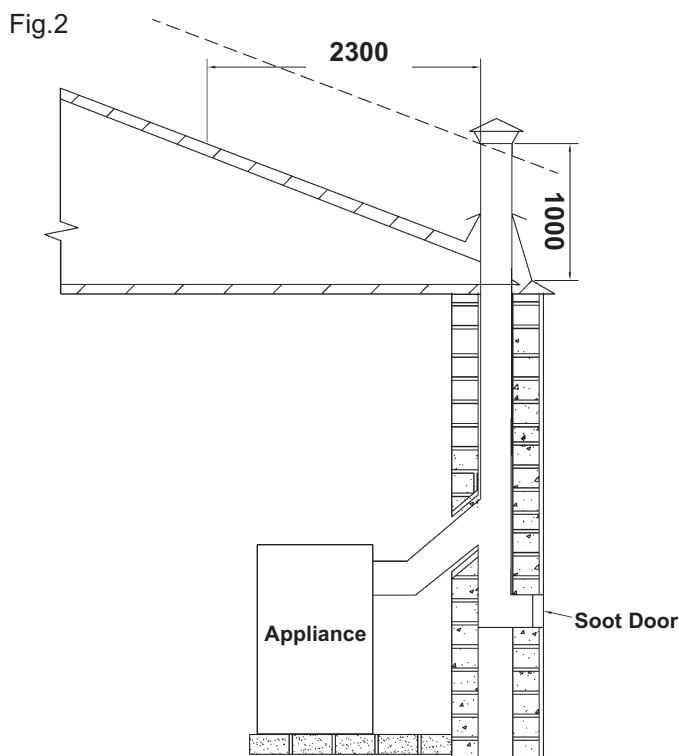

FLUE EXIT (TOP & REAR)

Fig.3

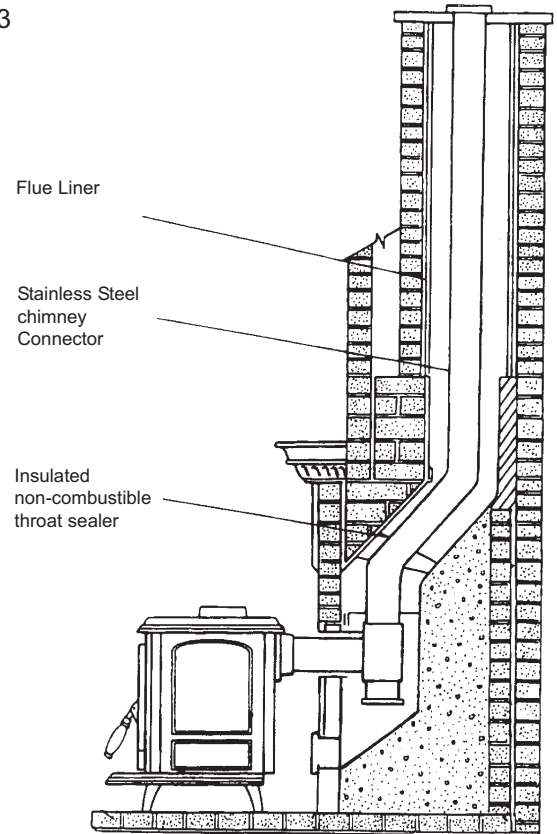

TOP FLUE EXIT

For the top outlet configuration, remove the blanking plate from the hob, remove the flue spigot from the back plate and fix it to the hob. Fix the outlet blanking plate to back plate (see Fig. 4). Push the flue outlet connector pipe (not supplied) into the flue spigot and cement into place using approved fire cement ensuring that no cement blocks the flue passageway.

Fig.4

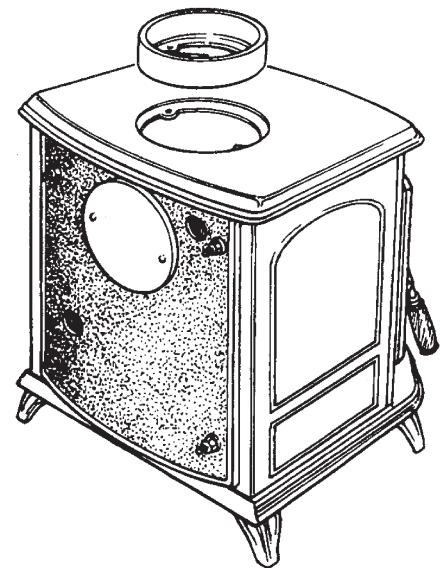

REAR FLUE EXIT

Push the flue connector pipe (not supplied) into the flue spigot and cement into place using approved fire cement ensuring that no cement blocks the flue passageway (see Fig.5).

Fig.5

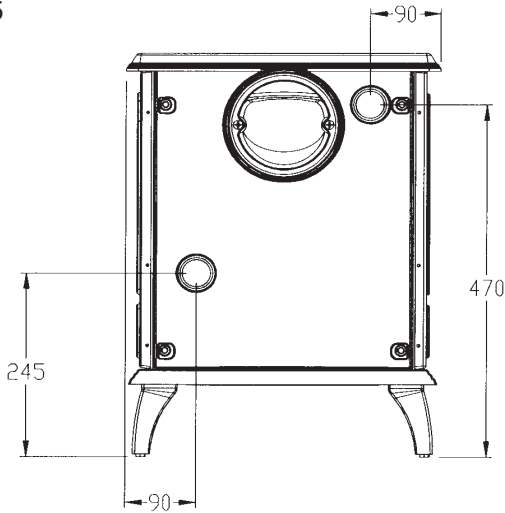

DOWN DRAUGHTS

However well designed constructed and positioned, the satisfactory performance of the flue can be adversely affected by down draught caused by nearby hills, adjacent tall buildings or trees. These can deflect wind to blow directly down the flue or create a zone of low pressure over the terminal.

A suitable anti-down draught terminal or cowl will usually effectively combat direct down blow but no cowl is likely to prevent down draught due to a low pressure zone. (See Fig.6)

Fig.6

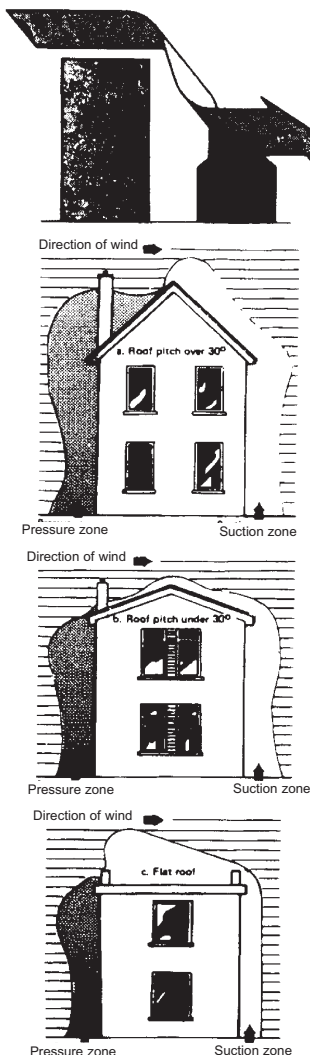

Note:

There must not be an extractor fan fitted in the same room as the stove as this can cause the stove to emit smoke and fumes into the room.

VENTILATION & COMBUSTION AIR REQUIREMENTS

It is imperative that there is sufficient air supply to the stove in order to support correct combustion. The air supply to this appliance must comply with current Building Regulations Part J, Heat Providing Appliances. If another appliance is fitted in an adjacent room it will be necessary to calculate an additional air supply.

All materials used in the manufacture of air vents should be such that the vent is dimensionally stable, corrosion resistant, and no provision for closure. The effective free area of any vent should be ascertained before installation. The effect of any grills should be allowed for when determining the effective free area of any vent.

Air vents should be positioned so that they are not liable to blockage.

Air vents direct to the outside of the building should be located so that any air current produced will not pass through normally occupied areas of the room.

An air vent outside the building should not be located less than the dimensions specified within the Building Regulations and B.S. 8303: Part 1 from any part of any flue terminal. These air vents must also be satisfactorily fire proofed as per Building Regulations and B.S. 8303: Part 1.

Air vents in internal walls should not communicate with bedrooms, bedsits, toilets, bathrooms or rooms containing a shower.

Air vents traversing cavity walls should include a continuous duct across the cavity. The duct should be installed in such a manner as not to impair the weather resistance of the cavity.

Joints between air vents and outside walls should be sealed to prevent the ingress of moisture. Existing air vents should be of the correct size and unobstructed for the appliance in use.

If there is an extraction fan fitted in adjacent rooms where this appliance is fitted, additional air vents may be required to alleviate the possibility of spillage of products of combustion from the appliance/flue while the fan is in operation. Refer to B.S. 8303 Part 1.

Where such an installation exists, a test for spillage should be made with the fan or fans and other appliances using air in operation at full rate, (i.e. extraction fans, tumble dryers) with all external doors and windows closed.

If spillage occurs following the above operation, an additional air vent of sufficient size to prevent this occurrence should be installed.

Epecially Airtight Properties:-

If the stove is being fitted in a property where the design air permeability is less than $5\text{m}^3 / (\text{h.m}^2)$ (normally newer properties built from 2006), then a permanent ventilation must be fitted to provide 550mm^2 of ventilation for each kW of rated output.

If a draught stabiliser is also fitted then the requirement is 850mm^2 per kW of rated output.

Note:

There must not be an extractor fan fitted in the same room as the stove as this can cause the stove to emit smoke and fumes into the room.

EXTERNAL DUCTED AIR

An outside air kit complete with primary air supply can be ducted from outside and is available to order for connection to the stove.

Fig.7

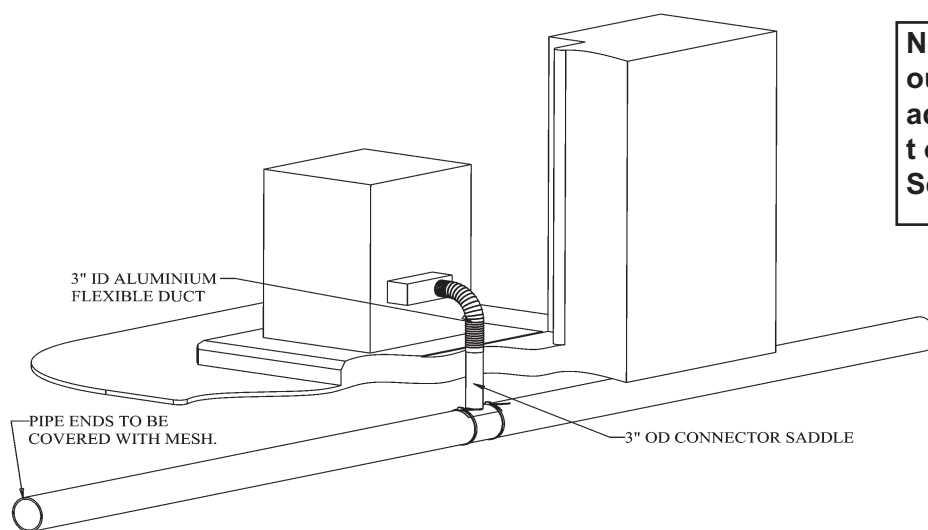

HEAT RECOVERY VENTILATION

Where a stove is to be installed in a dwelling with *Heat Recovery Ventilation* (HRV) a number of precautionary measures must be undertaken:

Should for example the delivery fan in the HRV unit fail and the extraction fan in HRV fan continue to run the HRV may create a pressure less than atmospheric, this low pressure will effect the flue pressure which is required to safely evacuate the products of combustion from the stove.

It is recommended to bring the air supply for the stove into the house using a 4" plastic pipe. Where the pipe meets the outside wall make sure a vent cover is fitted properly to ensure no rodents can enter via the vent pipe.

The vent pipe should be located to prevent the ingress of moisture and in a location where it will not get blocked with leaves or any other debris. As wind effects can create suction and pressure zones of opposite sides of the dwelling it is recommended to run the air vent from opposite poles (North, South, East & West) of the dwelling and tee off for the air supply to the stove. This should negate the effect of suction and pressure zones. See Fig. 7

'HETAS product approval covers this appliance when installed in accordance with the manufacturer's instructions and relevant standards. As there is currently no standard for Ducted Combustion Air Supply this does not fall within the remit for HETAS product approval. Responsibility for the specification of this and for appropriate manufacturer's instructions is carried by the appliance manufacturer, as allowed for under the Building Regulations.'

1. Fit an adequately sized vent in the room to prevent pressure less than atmospheric occurring. The size should be established by closing all windows and doors and then creating the possible failure situation. Then open a window in the room where the stove is fitted, slowly until the pressure reaches atmospheric. The size of the window opening should be measured and a vent of the corresponding size installed.
2. Fit a CO Alarm which has been approved to EN 50291.

LOCATION

There are several conditions to be considered in selecting a location for your Stanley Oisin Stove.

- Position in the area to be heated, central locations are usually best.
- Allowances for proper clearances to combustibles.
- Allowances for proper clearances for maintenance work.

CLEARANCE TO COMBUSTIBLES

Maintain at least the following clearances to all combustible material:

Side wall to stove	20" 510mm
Back wall to stove non-boiler model	15" 380mm
Back wall to stove boiler model	12" 305mm
Ceiling to horizontal connector	18" 460mm
Corner	13" 330mm
Mantle clearance	25" 635mm
Side trim, which extends less than 2" from the face of the fireplace	14" 355mm

It is recommended that this appliance is sited next to and on a non-combustible surface. A minimum all round clearance of 100 mm will allow air circulation and not impede the performance of the stove.

The connector may pass through walls or partitions constructed of combustible materials provided the connector is either listed for wall pass-through or is routed through a device listed for a wall pass-through and is installed in accordance with the conditions of the listing. Any unexposed metal that is used as part of a wall pass-through system is exposed to flue gases shall be constructed of stainless steel or other equivalent material that will resist corrosion, softening, or cracking from flue gas at temperatures up to 982°C.

Fig.8

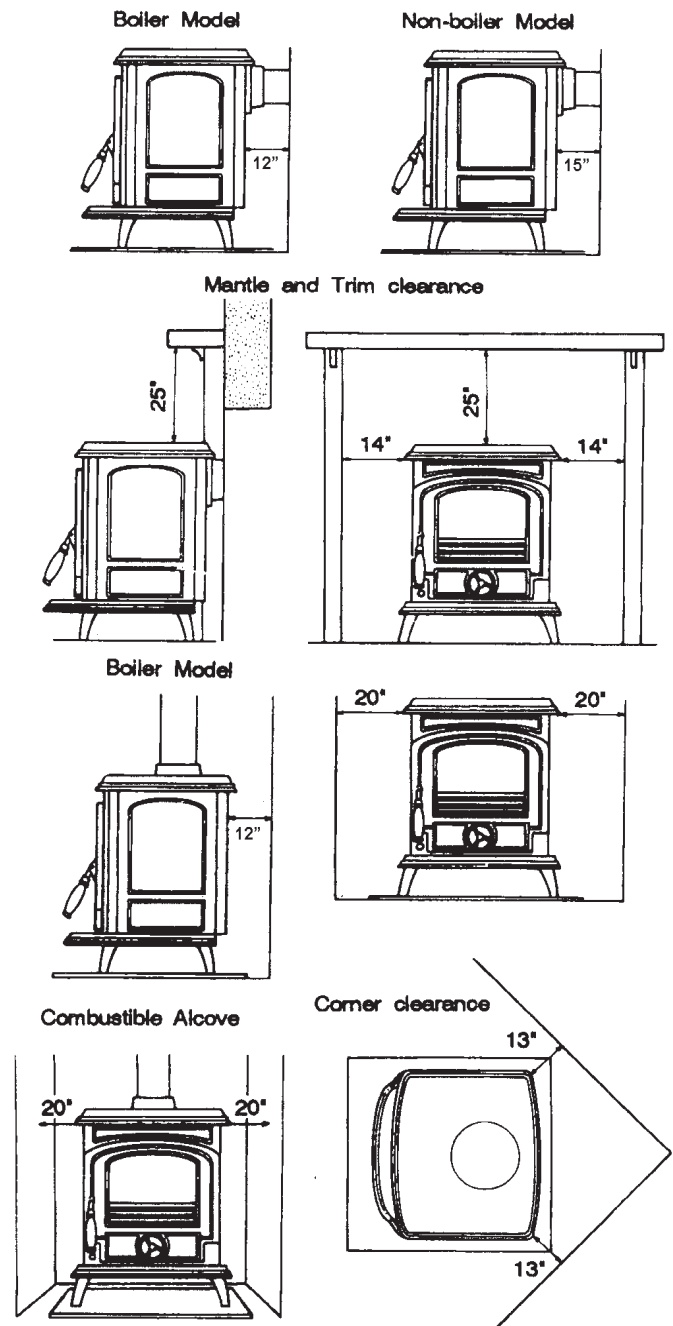

FLOOR PROTECTION

It is recommended that this appliance is installed on a solid, level, non combustible hearth conforming to current Building Regulations.

When installing this heater on a combustible floor , a floor protector, consisting of a layer of non-combustible material at least 3/8" thick or 1/4" thick covered with 1/8" sheet metal is required to cover the area under the heater and extend to at least 18" at the front and 8" to the sides and rear. This will provide protection from sparks and embers which may fall out from the door when stoking or fuelling. (See Fig.9)

Fig.9

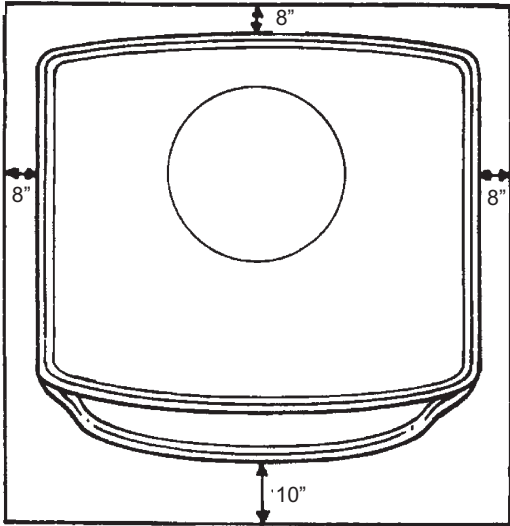

8. Insert boiler through the fire door.
9. Screw the two 28mm (1") flange nuts over the boiler connections. (Do not over tighten flange nuts).
10. Replace side bricks.
11. Replace fire bars. (See Fig.11)

Fig.11

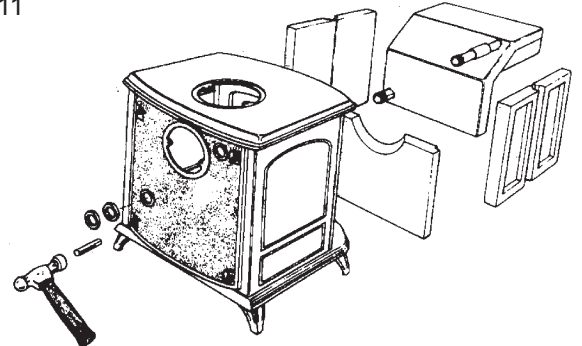

WARNING: DO NOT OBSTRUCT THE PRIMARY AIR SUPPLY TO THE SPIN VALVE AT THE FRONT OF THE STOVE.

PLUMBING

WATER PIPE LOCATIONS

Water connections 25mm (1") B.S.P (See Fig. 10)

Fig.10

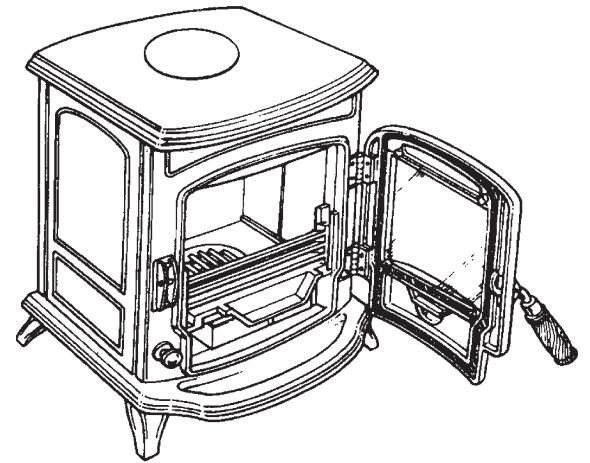
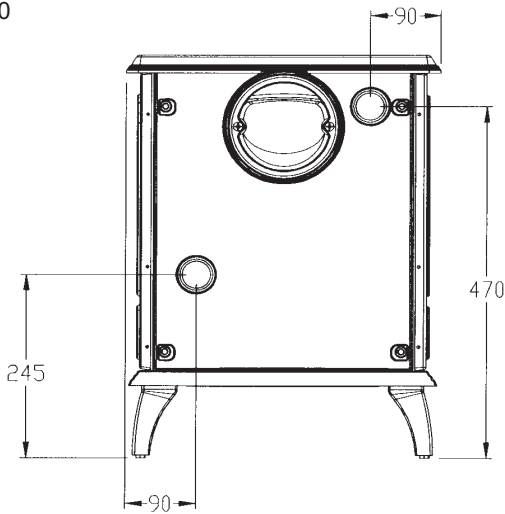

DOMESTIC HOT WATER SYSTEM (DHW MODEL ONLY)

The DHW Model must be connected to a gravity system. Care should be taken to ensure that the domestic hot water installation is correctly installed and that it complies with all relevant codes of practice. If this appliances is being connected to an existing system, it is strongly recommended to check the following:

(Fitting Optional DHW Boiler)

A stainless steel saddle boiler is available as an optional extra. Fit boiler as follows:

1. Open fire door.
2. Remove fire bars.
3. If the stove has already been in service thoroughly clean out the combustion chamber.
4. Remove side bricks.
5. Remove back brick.
6. Remove top baffle plate.
7. Punch out the two boiler tapping blanks on the back plate from the outside using a hammer and dolly.

- (a) That the system is sound.
- (b) That the pipe work is adequately insulated.
- (c) Are there any modifications necessary to make the domestic hot water system more efficient.

SAFETY VALVE

A non-adjustable 3 bar safety valve must be fitted to the primary flow pipe adjacent to boiler connection ensuring that any discharge will not create a hazard to occupants or cause damage to electrical components or property.

NOTE: We strongly advise the use of pipe lagging if the installation is likely to be exposed to situations where the temperatures will drop to a level consistent with frost.

Only competent personnel should be employed to carry out any work on your domestic hot water system.

DIRECT DOMESTIC CYLINDER

A 227 Litre (60 Gallon) direct domestic cylinder can be connected to this cooker using copper or stainless steel 28mm O.D. (1") flow & return pipes. We recommend that the cylinder is lagged along with the pipework. We do not recommend the use of a direct cylinder in areas where there is a high concentration of lime or minerals in the water.

INDIRECT DOMESTIC CYLINDER

A 227 Litre (60 Gallon) indirect domestic cylinder can be connected to this cooker using copper or stainless steel 28mm O.D (1") flow and return pipes. We recommend that the cylinder is lagged along the pipework.

PIPE THERMOSTAT

The fitting of a pipe thermostat to the flow pipe is essential in order to activate the water circulation pump when the water reaches the selected temperature.

When the water temperature falls below the selected temperature the pipe thermostat will cut off the water circulation pump in order to allow the boiler to recover.

Fig.12

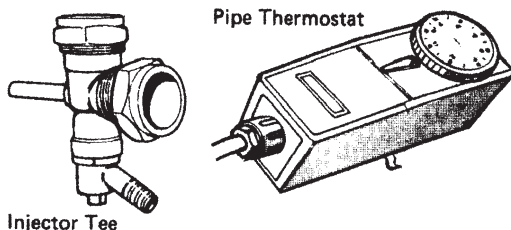

REGULATIONS

The plumbing must be in accordance with all relevant regulations and practices. It must include a gravity circuit with expansion pipe, open to the atmosphere. The central heating will normally be pump-driven as with other types of boilers.

GRAVITY CIRCUIT

The gravity circuit consists of the domestic hot water tank of 135 litres indirect cylinder, fixed in an upright position, recommended for hot water storage and it should be connected to the boiler by 28mm diameter flow and return piping. The pipes should not exceed 7.8 meters (25ft) in length and cylinder and pipework should be fully lagged. The shorter the run of pipe work the more effective the water heating.

The water system must be properly vented and a double feed indirect cylinder to the current issue of BS 1566, Copper indirect cylinders for domestic purposes, Part 1 Specification for double feed indirect cylinders is necessary where there is a combined hot water and central heating system.

Fig 13

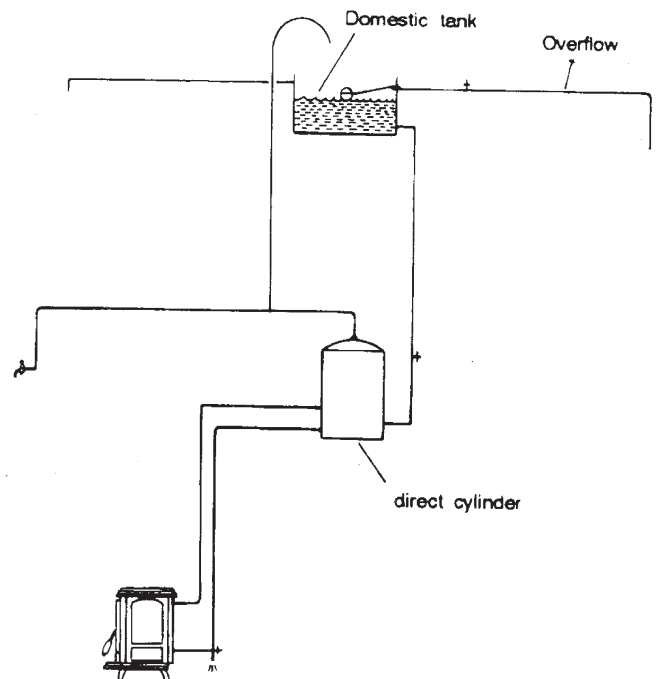

NOTE: (Boiler Model Only) In line water conditioners fitted to the cold mains supply both of chemical and magnetic type are suitable for use with the DHW stove.

STOVE DIMENSIONS

Fig.14

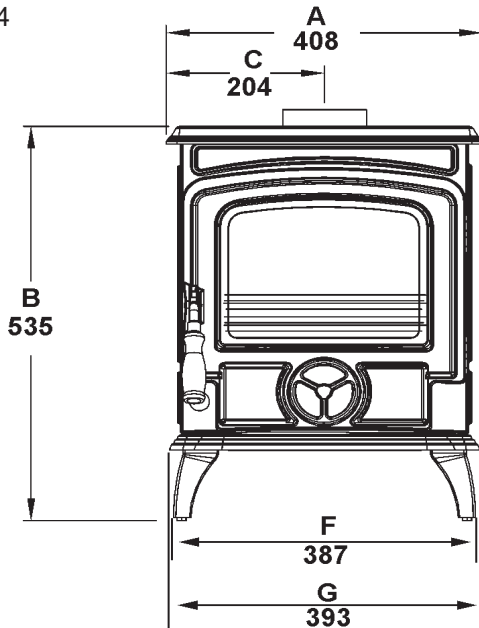
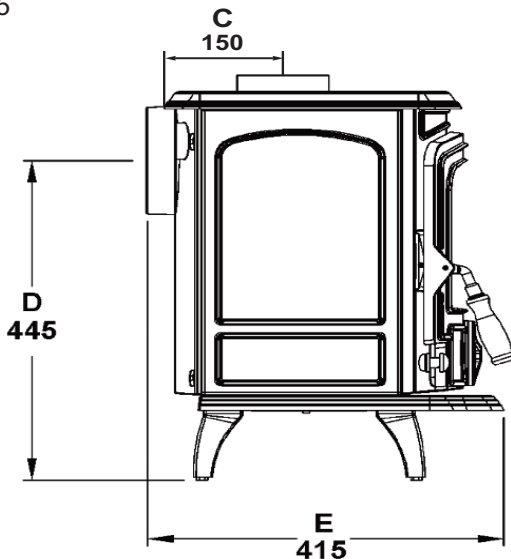

Fig.15



Note: Dimensions stated are in millimetres and may be subject to a slight +/- variation.

COMMISSIONING & HANDOVER

On completion of the installation allow a suitable period of time for any fire cement and mortar to dry out, when a small fire may be lit and checked to ensure the smoke and fumes are taken from the stove up the chimney and emitted safely to the atmosphere. **Do not run at full output for at least 24 hours.**

Ensure that the operating instructions for the stove are left with the customer. Ensure to advise the customer on the correct use of the appliance with the fuels likely to be used on the stove and warn them to use only the recommended fuels for the stove.

Advise the user what to do should smoke or fumes be emitted from the stove. The customer should be warned to use a fire guard to BS 8432: 2010 in the presence of children, aged and/or infirm persons.

OPERATION

Check that all dampers and catches are operating correctly and ensure that all flue connections are thoroughly sealed.

AIR CONTROLS

Primary air control

The spin valve, located at the bottom end of the door controls the primary and window wash air supply to the stove. For maximum heat output and burn rate rotate the spin valve fully in an anti-clockwise direction and for a minimum heat output and burn rate rotate the spin valve clockwise until fully closed. You will soon learn spin valve settings to best suit your requirements. (See Fig.16)

Fig.16

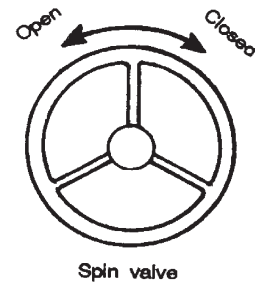

Note:

The controls may become hot when the stove is in operation, use tool or glove provided to adjust the controls when the stove is hot.

RECOMMENDED FUELS

All fuels should be stored under cover and kept as dry as possible prior to use.

This appliance has been tested using seasoned wood logs and manufactured briquetted smokeless fuel (Ancit) for closed appliances, sized between 20g and 140g. Other fuels are commercially available and may give similar results. Wood logs up to 340mm long are suitable. All fuels should be stored under cover and kept as dry as possible prior to use.

Do not use fuels with a Petro-coke ingredient as this may cause the grate to overheat, causing damage. Reduced outputs will result when fuels of lower calorific values are used. Never use gasoline or gasoline type lantern fuel, kerosene, charcoal lighter fluid or similar liquids to start or freshen up a fire in this heater. Keep all such liquid well away from the heater at all times. Operate the stove only with the fuelling door closed except for re-fuelling.

This stove has obtained HETAS Ltd approval for burning natural and manufactured smokeless fuels only as detailed in recommended fuels below. HETAS Approval does not cover the use of other fuels either alone or mixed with the recommended fuels listed, nor does it cover instructions for the use of other fuels.

TECHNICAL DATA

	MANUFACTURED SMOKELESS FUEL	WOOD
Max Output: (kW)	Room 6.4 kW	Room
Nominal Output (kW)	Room 4.2 kW	Room 5.7 kW
Typical refuelling intervals to obtain nominal outputs:	MSF 1 hour	WOOD .75 hrs
Mean Flue Gas Temperature °C	236	294
Gross Weight:	74 kgs	
Flue Outlet:	125 mm	
Efficiency	78.8%	79.4%
Flue Draught:	12 Pa	
Log Size:	N/A	240mm

Model	Energy Efficiency Class	Heat Output to Room	Heat Output to Water	Energy Efficiency Index	Preferred Fuel	Nominal Heat Output	Net Efficiency
Oisín NB SF Stove	A	5.7	N/A	106.13	Wood	5.7	79.4

LIGHTING

Before lighting the stove check with the installer that the installation work and commissioning checks described previously have been carried out correctly and that the chimney has been swept clean, is sound and free from any obstructions. As part of the stoves commissioning and handover the installer should demonstrate how to operate the stove correctly.

USER INSTRUCTIONS

1. Before lighting the stove, ensure that any build-up in the firebox has been removed and that the ashpan has been emptied.
2. Open the spin valve by turning it anti-clockwise until fully open.
3. Lay a few crumpled sheets of paper on the hearth and then a few small sticks, kindling or an approved firelighter.
4. Ignite and close the door.
5. **Never use inflammable liquid i.e. gasoline, petrol paraffin etc. to start or “freshen up” a fire in this heater.**
6. When the fire is well established add fuel to the firebox and adjust the spin valve to the required setting.

RE-FUELLING

Riddle the fire by connecting the grate operating tool onto the rocker connection located at the bottom front of the stove, then gently pull and push the rocker arm until all dead ash has fallen through into the ashpan. Before opening the door, open the spin valve by turning it anti-clockwise, as this will help to eliminate any smoke or fly ash resident in the combustion chamber. Add fuel to fire, close fire door and re-set spin valve to required setting. (See Fig.17)

Fig.17

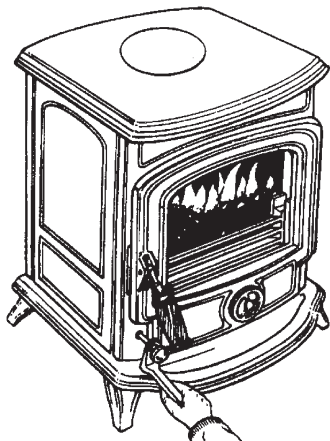

SLOW BURNING

Slow burning will cause the window glass to blacken and should not be used for a long period. Opening the air controls will increase the heat output and should remove most of the soot deposits from the glass. For slow burning setting open the spin valve so that it is between 0.5-1mm open. This opening size should be taken as a guideline and may need to be increased/ decreased depending on the draught generated by the chimney to which the stove is connected.

DE-ASHING

Never allow ashpan to over fill as it will cause damage to firebars.

Open the fire door and remove ashpan using the operating tool. Close the fire door. When the ash is disposed of, replace the empty ashpan. (See Fig.18)

Fig.18

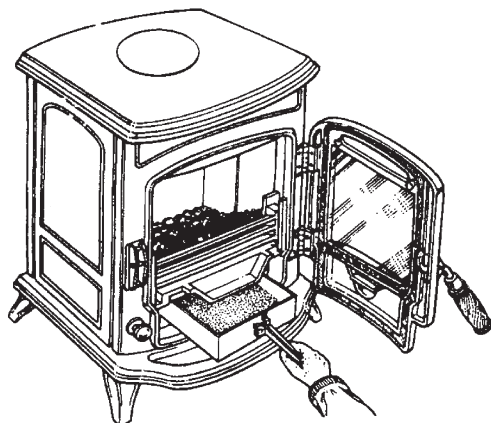

DISPOSAL OF ASH

Ashes should be placed in a metal container with a tight fitting lid. The closed container of ashes should be on a non-combustible floor or on the ground well away from all combustible materials pending final disposal. If the ashes are disposed of by burial in soil or other wise locally dispersed they should be retained in the closed container until all cinders have thoroughly cooled.

REMEMBER COAL GASES ARE TOXIC.

MONTHLY MAINTENANCE

To access the flue pathways, the top baffle should be removed from the stove through the fire door opening and cleaned thoroughly. To remove the top baffle, remove the firebars, and side bricks by lifting them up to allow the bottom of the brick to pass over the retaining rib on the grate. With the side bricks removed, the back brick can then be removed (it may be necessary to lift the top baffle to allow room to remove the bricks). Pull the baffle forward slightly so that it clears the positioning rib on the back casting. Lift up the baffle on the LHS side whilst sliding it the left until the RHS of the baffle can pass below the fixing rib on the RHS panel thus allowing the baffle drop into

the firebox and be removed from the stove. If the baffle is distorted & can't be removed as described above, the top casting can be removed to allow for access to the baffle.

If the stove is fitted with a boiler the area above the boiler should be thoroughly cleaned out using a suitable wire brush with a flexible handle. When inspecting a masonry chimney, start at the clean-out door, normally found at the base of the chimney, or on the outside. If your chimney does not have a clean-out door one should be provided.

PERIODIC MAINTENANCE

CHIMNEY CLEANING

Chimney and connector should be cleaned at least twice a year. Once before heating season and once after.

The chimney connector and chimney should be inspected at least monthly during the heating season to determine if a creosote build-up has occurred.

If the stove has no boiler, remove the cast iron baffle plate located at the top end of the firebricks before chimney cleaning.

GLASS CLEANING

The stove glass will self-clean when there is sufficient heat generated by the burning fuel i.e. when the unit is operated at the maximum air settings. If a build-up of creosote occurs on the glass it may be due to low draft conditions, poor quality fuel or operating the stove at the minimum air settings for long periods of time. The glass should be cleaned when cool and cleaned with a non-abrasive cloth using warm soapy water. For stubborn deposits, a grade 0 steel wool can be used whilst taking care not to scratch the glass with any coal/ash deposits.

VITREOUS ENAMEL CLEANING

General cleaning must be carried out when the stove is cool.

If this stove is finished in a high gloss vitreous enamel, to keep the enamel in the best condition observe the following tips:

1. Wipe over daily with a soapy damp cloth, followed by a polish with a clean dry duster.
2. For stubborn deposits a soap impregnated pad can be carefully used on the vitreous enamel.
3. Use only products recommended by the Vitreous Enamel Association, these products carry the Vitramel label.

A detailed list of the approved cleaners can be found on their website www.vea.org.uk/enamel-care/

DO NOT USE ABRASIVE PADS OR OVEN-CLEANSERS CONTAINING CITRIC ACID ON ENAMELLED SURFACES. ENSURE THAT THE CLEANSER MANUFACTURERS INSTRUCTIONS ARE ADHERED TO.

NOTE: Small impact marks on the enamel finish can be repaired using an appropriate enamel touch up (a touch up bottle is included with the stove packaging) but it should not be used to cover marks greater than $\varnothing 10\text{mm}$ or multiple marks on the same casting/area.

CLEANING A MATT BLACK/SENOTHERM STOVE

Cleaning should be done when the stove is cold by removing any dust or dirt using a dry cloth. Do not use any water on the matt black/senotherm finish as this will cause it to rust.

CHANGING THE ROPE SEALS

The rope seal between the door & the front casting will compress & harden over time and whilst small adjustments can be made to the door catch to ensure the integrity of the rope seal, it will be necessary to replace the rope seals on the stove periodically depending on stove usage. It is recommended that the rope seals are changed at least every two years.

PROLONGED PERIODS OF NON USE

If the stove is to be left unused for a prolonged period of time then it should be given a thorough clean to remove ash and unburned fuel residues. To enable a good flow of air through the appliance to reduce condensation and subsequent damage, leave the air controls fully open.

It is important that the flue connection, any appliance baffles or throat plates and the chimney are swept prior to lighting up after a prolonged shutdown period.

WARNING NOTE:

Properly installed, operated and maintained this stove will not emit fumes into the dwelling. Occasional fumes from the de-ashing and re-fuelling may occur. However, persistent fume emission is potentially dangerous and must not be tolerated. If fume emission does persist, then the following immediate action should be taken:

- (a) Open doors and windows to ventilate room.
- (b) Let the fire out or eject and safely dispose of fuel from the stove.
- (c) Check for flue or chimney blockage and clean if required.
- (d) Do not attempt to relight the fire until the cause of the fume emission has been identified and corrected. If necessary seek expert advice.

The most common cause of fume emission is flue-way or chimney blockage. For your own safety these must be kept clean at all times.

FIRE SAFETY

To provide reasonable fire safety, the following should be given serious consideration.

1. Do not over fire the stove.
2. Over-firing will also damage painted or enamel finish.
3. Install a smoke detector in the room.
4. A conveniently located class A fire extinguisher to contend with small fires resulting from burning embers.
5. A practical evacuation plan.
6. A plan to deal with a chimney fire as follows:-
 - (a) Notify the fire department.
 - (b) Prepare occupants for immediate evacuation.
 - (c) Close all openings into the stove.
 - (d) While awaiting the fire department watch for ignition to adjacent combustibles from overheated flue pipe or from embers or sparks from the chimney.

GLASS REPLACEMENT

- a. Open the door fully.
- b. Remove the four corner screws and clips and carefully remove the broken glass.
- c. Clean the glass recess in the door.
- d. Attach adhesive thermal tape to the perimeter of the replacement glass.
- e. Place the thermal tape side of the glass into the door recess and replace the four corner clips.
- f. Tighten screws.
- g. Replace glass only with ceramic glass 5mm thick. (See Fig.19)

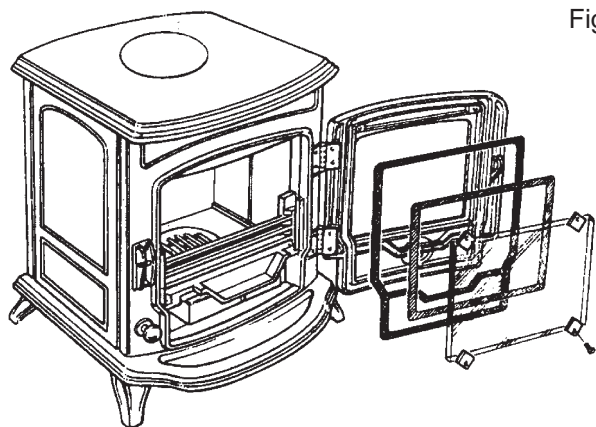

Fig.19

CO ALARM

The fitting of CO Alarms in the same room as the appliance is a compulsory requirement under current Building Regulations. For ROI an additional CO Alarm must be fitted either inside each bedroom or within 5 metres of the bedroom door, refer to Building Regulations Part J. Further guidance on the installation of a carbon monoxide alarm is available in BS EN 50292:2002 and from the alarm manufacturers instructions.

Provision of an alarm must not be considered a substitute for either installing the appliance correctly or ensuring regular servicing and maintenance of the appliance and chimney system.

WARNING:-

If the CO Alarm sounds unexpectedly:-

- 1. Open Doors and windows to ventilate the room and then leave the premises.**
- 2. Let the fire go out.**

OISIN SF NB EXPLODED VIEW

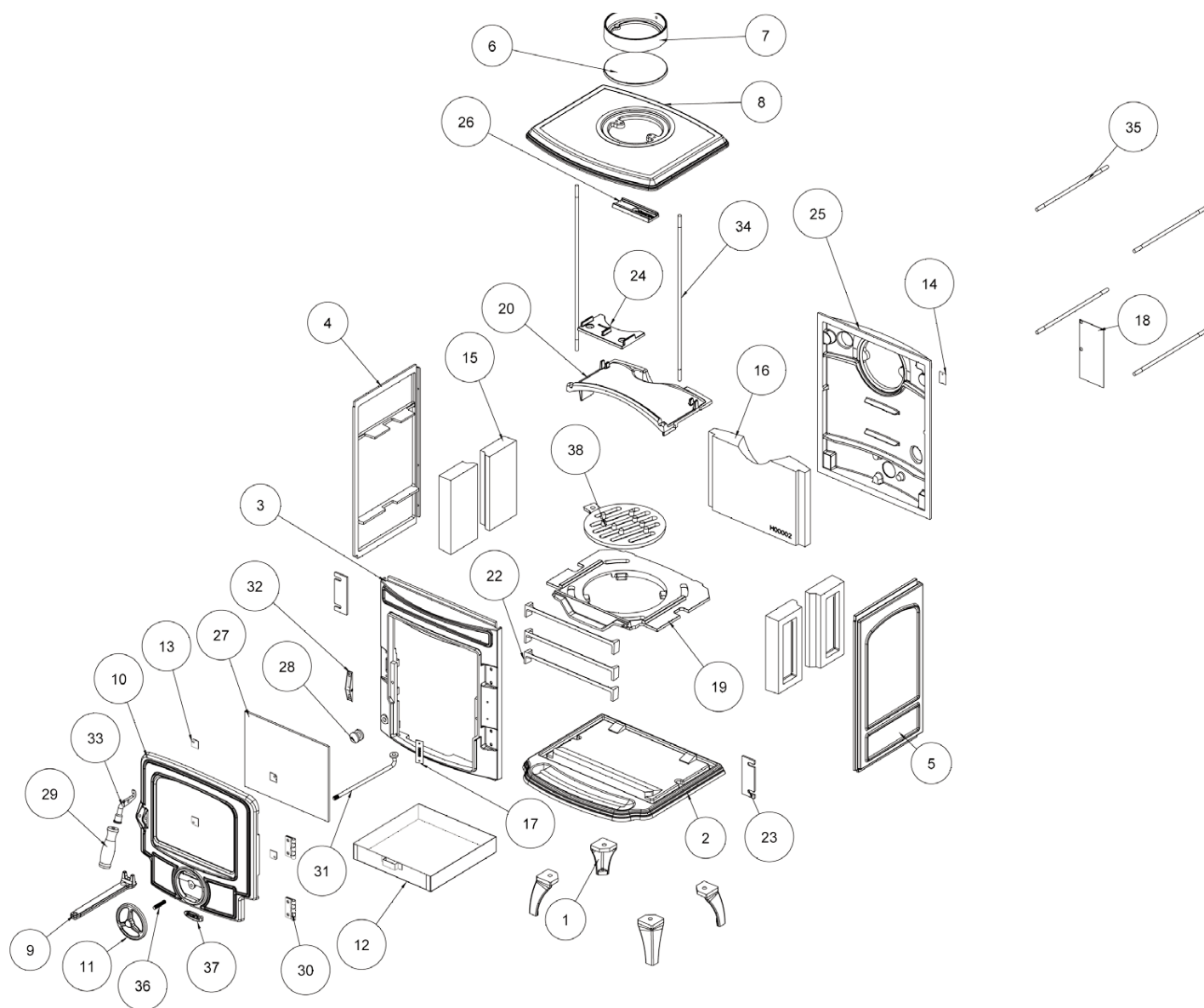

- | | |
|---------------------------------------------|---------------------------------------------|
| 1. LEG (SHORT) - B00001AXX | 24. HOB PROTECTION PLATE - Q00007AXX |
| 2. BASE - B00002AXX | 25. BACK PANEL - Q00576CXX |
| 3. FRONT FRAME - B00003BXX | 26. BRACE PLATE - Q00759AXX |
| 4. LH SIDE PLATE - B00004CXX | 27. GLASS WINDOW - T00001AXX |
| 5. RH SIDE PLATE - B00005CXX | 28. PULL ROD KNOB - U00001AXX |
| 6. HOB BLANKING PLATE - B00006AXX | 29. DOOR HANDLE (LONG) - U00009AXX |
| 7. FLUE SPIGOT - B00007BXX | 30. HINGE - U00153AXX |
| 8. HOB - B00008BXX | 31. GRATE CONNECTING ROD - V00001AXX |
| 9. OPERATING TOOL - B00009DXX | 32. DOOR CATCH - V00002AXX |
| 10. FRONT DOOR - B00010HXX | 33. DOOR LATCH - V00003BXX |
| 11. SPIN VALVE - B00012AXX | 34. LONG TIE BOLT - V00052AXX |
| 12. ASHPAN - F00001AXX | 35. TIE ROD (M8 * 260MM) - V00053AXX |
| 13. DOOR GLASS CLIP - F00003AXX | 36. M8*39 SPINDLE - V00703BXX |
| 14. RATING PLATE BRACKET - V01072AXX | 37. BADGE - V00730BXX |
| 15. SIDE BRICK - H00001AXX | 38. GRATE - Z00025BXX |
| 16. BACK BRICK - H00002AXX | |
| 17. SERIAL NUMBER PLATE - N00234BXX | |
| 18. DATA PLAQUE - N00440AXX | |
| 19. GRATE SUPPORT PLATE - Q00001BXX | |
| 20. TOP BAFFLE - Q00003AXX | |
| 22. FIRE FENCE - Q00005AXX | |
| 23. FIRE FENCE RETAINER - Q00006AXX | |

Manufactured by
Waterford Stanley Ltd.,
Unit 401-403, IDA Industrial Estate, Cork Road,
Waterford, Ireland.
Tel: (051) 302300 Fax (051) 302315

