PLEASE RETAIN



Ardmore

Boiler Solid Fuel Stove



INSTALLATION AND OPERATING INSTRUCTIONS

This appliance is hot while in operation and retains its heat for a long period of time after use. Children, aged or infirm persons should be supervised at all times and should not be allowed to touch the hot working surfaces while in use or until the appliance has thoroughly cooled.

When using the boiler stove in situations where children, aged and/or infirm persons are present a fireguard must be used to prevent accidental contact with the stove. The fireguard should be manufactured in accordance with BS 8423:2002.

TABLE OF CONTENTS

	PAGE NO.
1. Stanley Solid Fuel Stove Warranty	3
2. Installation Checklist	4
3. Important Operation/ Maintenance Notes	5
4. Installation & Operating Instructions	6
5. General	6
6. Electrical Connections	6
7. Flues	6
8. Chimney	6
9. Flue Exit - Top and Rear	7
10. Down Draughts	8
11. Ventilation and Combustion Air Regulations	8
12. Location	9
13. Clearances To Combustibles	9
14. Floor Protection	9
15. Plumbing	9
16. Pipe Thermostat	9
17. Regulations	10
18. Gravity Circuit	10
19. Injector Tee	10
20. Water Circuit Temperature	10
21. Flue & Water Pipe Locations	11
22. Stove Dimensions	12
23. Commissioning and Handover	12
24. Operation	12
25. Air Controls	12
26. Recommended Fuels	13
27. Technical Data	14
28. Lighting	14
31. User Instructions	14
33. Lighting The Stove	14
34. Refuelling	15
35. Slow Burning	15
36. De-Ashing	15
37. Disposal of Ashes	15
38. Monthly Maintenance	15
39. Periodic Maintenance	16
40. Chimney Cleaning	16
41. Glass Cleaning	17
42. Vitreous Enamel Cleaning	17
43. Cleaning a Matt Black/ Senotherm Stove	17
44. Frozen System	17

TABLE OF CONTENTS

	PAGE NO.
45. Prolonged Periods of Non Use	17
46. Fire Safety	17
47. Glass Replacement	18
48. CO Alarm	18
49. Exploded View	19



CONDITIONS OF WARRANTY

Your Stanley Solid Fuel Stove is guaranteed against any part that fails (under normal operating conditions) as detailed in the following table with timelines specified from the date of installation of the appliance. If the unit is not installed within six months of date of purchase, the warranty will commence six months from the date of purchase.

Warranty Period	Parts Covered (Parts & Labour unless Stated)
Up to 1 Year	<ul style="list-style-type: none"> • Refractory materials (supply only) • Rope seals, glass seals and cement seals. • Surface Finish on Seno models. • Grates and fire bars. • Ceramic glass is covered for Thermal breakage (supply only). • Rust (if reported before installation) • Aesthetic Damage (provided reported on date of receipt)
Up to 5 Years	<ul style="list-style-type: none"> • All external castings & enamel finishes (excluding impact damage or damage caused by overfiring). Pictures of damage must be submitted to WS Service Department.
Up to 3 Years	<ul style="list-style-type: none"> • Boiler - A Leaking Boiler Report must be conducted by an Authorised Stanley Service Engineer and submitted to WS Service Department for review.

All warranty claims must be reported to the Waterford Stanley Service Department and must be submitted with the product serial number (located on the front casting), date of purchase, proof of purchase (if requested) and details of the specific nature of the problem.

The warranty is given only to the original consumer/purchaser only and is non-transferable. The appliance must be installed by a suitable qualified person and installed as per the requirements of the manual. Failure to comply with the Installation requirements or Building Regulations will void your warranty. Waterford Stanley reserve the right to replace any part due to manufacturing defect that fails within the warranty period under the terms of the warranty. The unit must be used for normal domestic purposes only and in accordance with manufacturer's operation instructions.

LIMITS OF LIABILITY

The warranty does not cover:

- * Special, incidental or consequential damages, injury to persons or Property, or any other consequential loss.
- * Any issue caused by negligence, misuse, abuse or circumstances beyond Waterford Stanley's control.
- * Any issue with wear and tear, modification, alteration, or servicing by anyone other than an authorized service engineer.
- * Installation and operational related problems such as draught related issues external to the stove, inadequate venting or ventilation, excessive flue offsets, negative air pressure caused by insufficient burning of improper fuel.
- * Damage caused to the unit while in transit.
- * Enamel discolouration due to over firing, enamel damage caused by impact, damage to baffles caused by over firing and fading of surface finish on casting.
- * Stress fractures on bricks.
- * Rust on cast iron parts unless reported prior to unit being installed.
- * Aesthetic damage, rust & missing parts on units purchased off display.

Note: Adequate clearance must be maintained around the appliance to ensure the ease of part removal in the possible event of their damage/failure. Waterford Stanley are not responsible for any costs incurred in the removal of items installed in the vicinity of the appliance that have to be moved to facilitate a part replacement.

INSTALLATION CHECK LIST

Tick

Flue System

1. Minimum Flue Height of 4.6 metres (15 feet).
2. Appliance should be connected to a 125mm (5") flue pipe within a metre and then the flue size increased to a minimum of 150mm (6") diameter.
3. The horizontal flue run should not exceed 150mm (6")
4. All flue pipework passing through walls must be sleeved & adequately insulated in line with current Building Regulations.
5. Appliance should be connected to a chimney of less than 200mm (8") in diameter (otherwise the chimney must be lined with a 6" flue liner).
6. The chimney/ flue termination must be located in accordance with building regulations part J.
7. The chimney serving this appliance should not serve any other appliance.
8. Access should be provided to the chimney serving the appliance to allow for cleaning.
9. It is a requirement by Building Regulations to have a carbon monoxide alarm fitted to any room with a solid fuel appliance.

Location

10. Clearance to combustible materials must be adhered to as described in the Clearance to Combustible section.
11. The stove must be installed on a floor protector that covers the area under the stove and extends 18" to the front, 12" to back and 4" to the sides.
12. Clearance must be maintained to allow for maintenance and part replacement.

Ventilation & Combustion Air Requirements

13. The room in which the appliance is located should have an air vent of adequate size to support correct combustion (see Ventilation & Combustion Air Requirement Section for specific details).
14. The stove must not be installed in the same room as an extractor fan.

Plumbing and Electrical Requirements

15. All plumbing and electrical work associated with the appliance must be conducted in accordance with current Building Regulations, Maintenance Instructions and Best Practice Guidelines.



IMPORTANT OPERATION / MAINTENANCE NOTES

Now that your Stanley Solid Fuel Stove is installed and no doubt you are looking forward to many comforts it will provide, we would like to give you some tips on how to get the best results from your stove.

1. We would like if you could take some time to read the operating instructions/hints, which we are confident, will be of great benefit to you.
2. Do not burn fuel with a high moisture content, such as a damp peat or unseasoned timber. This will only result in a build up of tar in the stove and in the chimney.

FUEL CALORIFIC VALUES - SOLID FUELS		
Anthracite 25-50mm	C.V.: 8.2kW/Kg	14,000 BTUs/lb
House Coal 25-75mm	C.V.: 7.2kW/Kg	12,000 BTUs/lb
Timber - Firebox size	C.V.: 5.0kW/Kg	8,600 BTUs/lb
Peat Briquettes	C.V.: 4.8kW/Kg	8,300 BTUs/lb

3. **IMPORTANT:** The first few fires should be relatively small to permit the refractory to set properly and season the stove. During these firings it is recommended to ventilate the room as an unpleasant (not toxic) odour may be emitted as the paint is completing curement.
4. **Inspect the flue-ways of the stove weekly and ensure that there are no blockages. Check flue ways before lighting especially after a shut down period. Please see chimney cleaning section.**
5. Before loading fresh fuel into the firebox, riddle fully to remove all ashes. This will allow better and cleaner burning. See Re-Fuelling section.
6. Never allow a build up of ashes in the ash pan, as this will cause the grate to burn out prematurely. Empty the ashpan when refuelling.
7. Avoid slow burning of damp or unseasoned fuel as this will result in tarring flue ways and chimney i.e. peat or timber.
8. Allow adequate air ventilation to ensure plenty of air for combustion.
9. Do not burn rubbish/household plastic.
10. Clean the chimney at least twice a year.
11. Burning soft fuels such as timber and peat will stain the glass. Regular cleaning will prevent permanent staining. Clean with soapy water when cool.
12. Keep all combustible materials a safe distance away from unit, please see section for clearances to combustibles.
13. Never use aerosol spray near the appliance when it is in operation.
14. For safety reasons never leave children or the elderly unaccompanied while stove is in use. Use a fire guard.
15. Avoid contact with the appliance when in use as stove reaches very high operating temperatures.
16. This appliance should be regularly maintained by a competent service engineer.

THE SOLID FUEL CENTRAL HEATING STOVE INSTALLATION & OPERATING INSTRUCTIONS

GENERAL

When installing, operating and maintaining your Ardmore Stove respect basic standards of fire safety. Read these instructions carefully before commencing the installation. Failure to do so may result in damage to persons and property. Consult your local Municipal office and your insurance representative to determine what regulations are in force. Save these instructions for future reference.

Please note that it is a legal requirement under England & Wales Building Regulations that the installation of the stove is either carried out under Local Authority Building Control approval or is installed by a Competent Person registered with a Government approved Competent Persons Scheme. HETAS Ltd operate such a scheme and a listing of their Registered Competent Persons can be found on their website at www.hetas.co.uk.

Special care must be taken when installing the stove such that the requirements of the Health & Safety at Work Act are met.

Handling

Adequate facilities must be available for loading, unloading and site handling.

Fire Cement

Some types of fire cement are caustic and should not be allowed to come into contact with the skin. In case of contact with the skin wash immediately with plenty of water.

Asbestos

This stove contains no asbestos. If there is a possibility of disturbing any asbestos in the course of installation then please seek specialist guidance and use appropriate protective equipment.

Metal Parts

When installing or servicing this stove care should be taken to avoid the possibility of personal injury.

“IMPORTANT WARNING”

This stove must not be installed into a chimney that serves any other heating appliance.

The complete installation must be done in accordance with current Standards and Local Codes. It should be noted that the requirements and these publications may be superseded during the life of this manual.

Please refer to the current standards, BS EN 15287-1:2007 Design, Installation and Commissioning of chimneys. BS EN 14336:2004: Heating Systems in Buildings. Installation & Commissioning of Water Based Heating Systems. BS EN 12828: 2003; Heating Systems in Buildings. Design of Water Based Heating Systems. BS EN 12831: 2003; Heating Systems in Buildings. method for calculation of the design heat load.

Your Ardmore stove is supplied with the following items:

- Ashpan
- Operating Tool
- Touch-Up Paint (Enamel Only)
- Glove
- Flue Spigot
- Thermostat Knob

ELECTRICAL CONNECTIONS

The installation of any electrical services during the installation of this stove must be carried out by a registered competent electrician and in accordance with the requirements of the latest issue of BS 7671.

FLUES

Flues should be vertical wherever possible and where a bend is necessary, it should not make an angle of more than 45° with the vertical. Horizontal flue runs should be avoided except in the case of a back outlet from the appliance, when the length of the horizontal section should not exceed 150mm.

CHIMNEY

Do not connect to a chimney serving another appliance.

The stove is a radiant room heater and must be connected to a chimney of the proper size and type.

The chimney must have a cross-sectional area of at least 30 square inches 19350sq. mm or a diameter of at least 6” (150mm). The stove is supplied with a 5” flue spigot, the flue installation will require a 5” to 6” increaser which must be fitted within 1 metre of flue outlet. It is best to connect to a chimney of the same size, as connection to a larger size may result in a somewhat less draught.

A flue that has proved to be unsatisfactory, particularly with regard to down draught should not be used for venting this appliance until it has been examined and any faults corrected. An existing masonry chimney should be inspected and if necessary repaired by a competent mason or relined using an approved lining system.

The stove must be connected to a chimney with a minimum continuous draught of 0.06 w.g. Poor draught conditions will result in poor performance.

All register plates, restricter plates, damper etc., which could obstruct the flue at a future date should be removed before connecting this appliance.

If connecting to an existing chimney with a flue diameter of more than 8" it is recommended to line the flue using a suitable stainless steel flue liner.

Where a masonry chimney is not available a proprietary type of 6"/150mm - twin wall, fully insulated pipe may be used. The pipe must terminate at a point not lower than the main ridge of adjacent outside obstructions. With such installation, access to the chimney must be provided for cleaning purposes.

A chimney / flue termination must be located to minimise wind effects, a basic guide is that the distance from the termination to the roof should be at least 2300mm when measured horizontally and at least 1000mm when measured vertically, (see Fig.1). In circumstances where there are adjoining buildings/ structures/ roof openings there are additional requirements, please refer to building regulations part J.

Fig.1

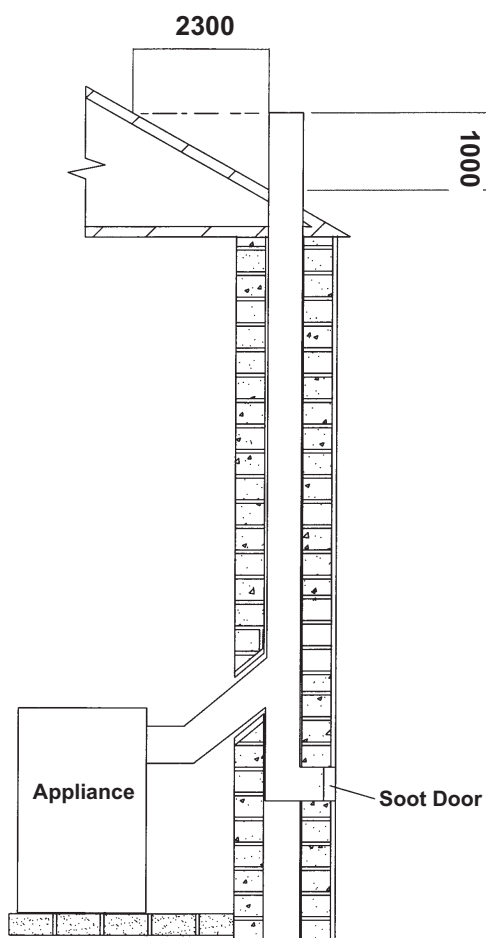

FLUE EXIT (TOP & REAR)

The stove is designed to allow the chimney to be cleaned through the stove. If the chimney cannot be cleaned through the stove it is necessary to provide a soot box/access door in the flue for cleaning. See Fig.2 for recommended locations. Fit it to the stove as shown in Fig.2.

The stove is supplied with a hob blanking plate and a flue blanking plate. The flue blanking plate can be altered for use with both top outlet and rear outlet. The hob blanking plate is for use when the stove is fitted on rear outlet only. Make sure the flue blanking plate is sealed correctly. See Figs 3 & 4

Fig.2

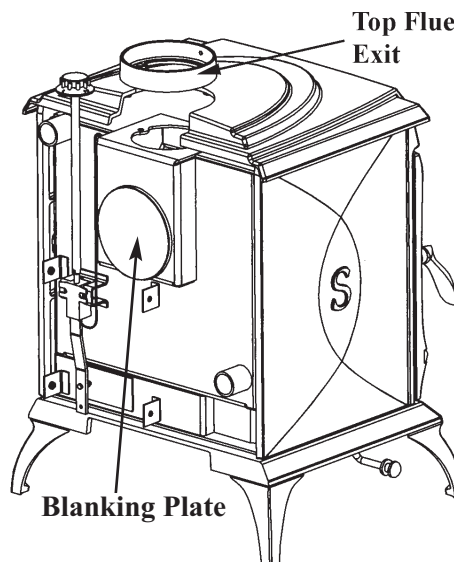
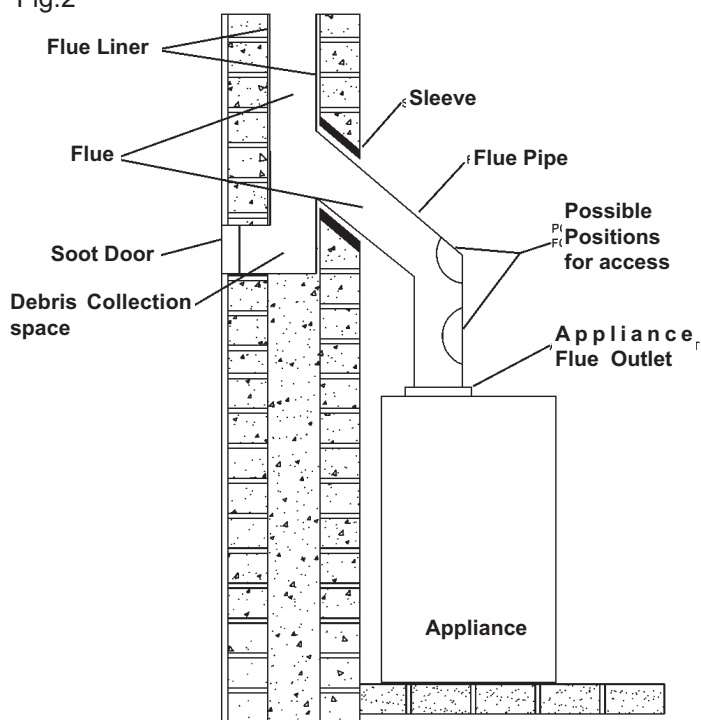
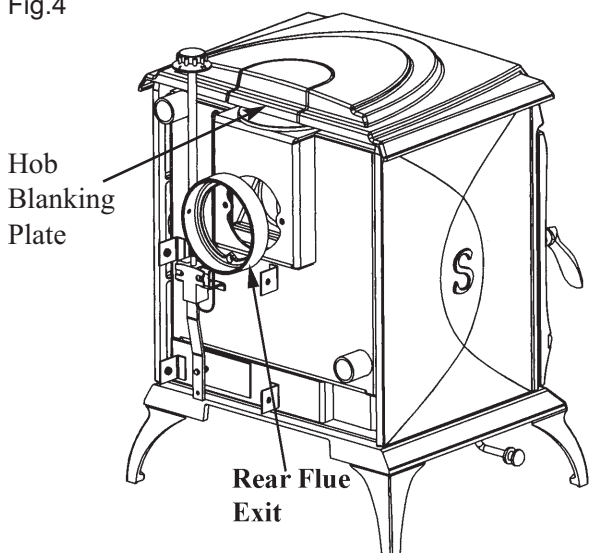

Fig.4



DOWN DRAUGHTS

However well designed constructed and positioned, the satisfactory performance of the flue can be adversely affected by down draught caused by nearby hills, adjacent tall buildings or trees. These can deflect wind to blow directly down the flue or create a zone of low pressure over the terminal.

A suitable terminal or cowl will usually effectively combat direct down blow but no cowl is likely to prevent down draught due to a low pressure zone. (See Fig.5)

Fig.5

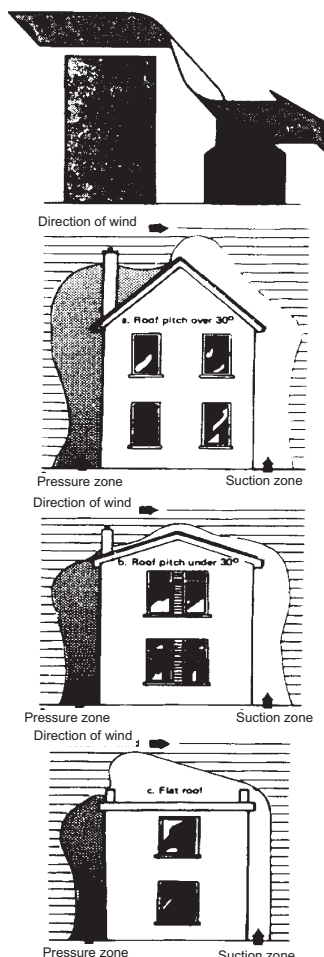

VENTILATION & COMBUSTION AIR REQUIREMENTS

It is imperative that there is sufficient air supply to the stove in order to support correct combustion. The air supply to this appliance must comply with current Building Regulations Part J, Heat Providing Appliances. If another appliance is fitted in an adjacent room it will be necessary to calculate an additional air supply.

The minimum effective air requirement for this appliance is 71.5cm². When calculating combustion air requirements for this appliance use the following equation:

550mm² per each kw of rated output above 5kw should be provided, where a flue draught stabiliser is used the total free area shall be increased by 300mm² for each kw of rated output.

NOTE:

There must not be an extractor fan fitted in the same room as the stove as this can cause the stove to emit smoke and fumes into the room.

All materials used in the manufacture of air vents should be such that the vent is dimensionally stable, corrosion resistant, and no provision for closure.

The effective free area of any vent should be ascertained before installation. The effect of any grills should be allowed for when determining the effective free area of any vent.

Air vents should be positioned so that they are not liable to blockage.

Air vents direct to the outside of the building should be located so that any air current produced will not pass through normally occupied areas of the room.

An air vent outside the building should not be located less than the dimensions specified within the Building Regulations and B.S. 8303: Part 1 from any part of any flue terminal. These air vents must also be satisfactorily fire proofed as per Building Regulations and B.S. 8303: Part 1.

Air vents in internal walls should not communicate with bedrooms, bedsits, toilets, bathrooms or rooms containing a shower. Air vents traversing cavity walls should include a continuous duct across the cavity. The duct should be installed in such a manner as not to impair the weather resistance of the cavity.

Joints between air vents and outside walls should be sealed to prevent the ingress of moisture. Existing air vents should be of the correct size and unobstructed for the appliance in use.

If there is an extraction fan fitted in adjacent rooms where this appliance is fitted, additional air vents may be required to alleviate the possibility of spillage of products of combustion from the appliance/flue while the fan is in operation. Refer to B.S. 8303 Part 1. Where such an installation exists, a test for spillage should be made with the fan or fans and other appliances using air in operation at full rate, (i.e. extraction fans, tumble dryers) with all external doors and windows closed.

If spillage occurs following the above operation, an additional air vent of sufficient size to prevent this occurrence should be installed.

Especially Airtight Properties:-

If the stove is being fitted in a property where the design air permeability is less than $5\text{m}^3 / (\text{h.m}^2)$ (normally newer properties built from 2006), then a permanent ventilation must be fitted to provide 550mm^2 of ventilation for each kW of rated output. If a draught stabiliser is also fitted then the requirement is 850mm^2 per kW of rated output.

EXTERNAL DUCTED AIR

An outside air kit complete with primary air supply can be ducted from outside and is available to order for connection to the stove.

It is recommended to bring the air supply for the stove into the house using a 4" plastic pipe. Where the pipe meets the outside wall make sure a vent cover is fitted properly to ensure no rodents can enter via the vent pipe.

The vent pipe should be located to prevent the ingress of moisture and in a location where it will not get blocked with leaves or any other debris. As wind effects can create suction and pressure zones on opposite sides of the dwelling it is recommended to run the air vent from opposite poles (North, South, East & West) of the dwelling and tee off for the air supply to the stove. This should negate the effect

'HETAS product approval covers this appliance when installed in accordance with the manufacturer's instructions and relevant standards. As there is currently no standard for Ducted Combustion Air Supply this does not fall within the remit for HETAS product approval. Responsibility for the specification of this and for appropriate manufacturer's instructions is carried by the appliance manufacturer, as allowed for under the Building Regulations.'

Fig.6

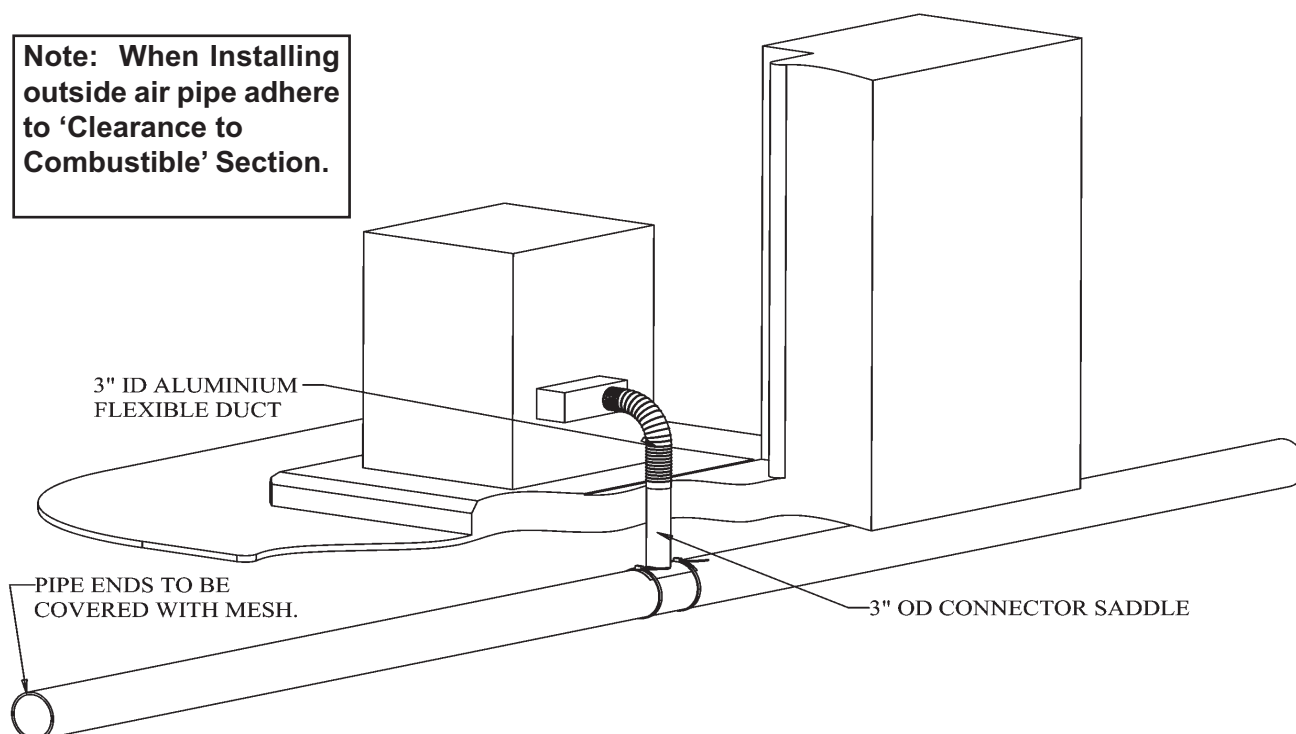

HEAT RECOVERY VENTILATION

Where a stove is to be installed in a dwelling with *Heat Recovery Ventilation* (HRV) a number of precautionary measures must be undertaken:

Should for example the delivery fan in the HRV unit fail and the extraction fan in HRV fan continue to run the HRV may create a pressure less than atmospheric, this low pressure will effect the flue pressure which is required to safely evacuate the products of combustion from the stove.

1. Fit an adequately sized vent in the room to prevent pressure less than atmospheric occurring. The size should be established by closing all windows and doors and then creating the possible failure situation. Then open a window in the room where the stove is fitted, slowly until the pressure reaches atmospheric. The size of the window opening should be measured and a vent of the corresponding size installed.
2. Fit a CO Alarm which has been approved to EN 50291.

LOCATION

There are several conditions to be considered in selecting a location for your Stanley Ardmore Stove.

- a. Position in the area to be heated, central locations are usually best.
- b. Allowances for proper clearances to combustibles.
- c. Allowances for proper clearances for maintenance work.

CLEARANCE TO COMBUSTIBLES

Maintain at least the following clearances to all combustible material:

From the front	460 mm (18")
From the back	300 mm (12")
From the sides	100 mm (4")
From the flue pipe	760 mm (30") straight up only

It is recommended that the appliance is sited next to and on a non-combustible surface. A minimum all round clearance of 150mm will allow air circulation and will not impede the performance of the stove.

FLOOR PROTECTION

When installing this heater on a combustible floor, a floor protector consisting of a layer of non combustible material at least 310mm thick covered with "1/8 sheet metal" is required to cover the area under the heater and extend at least 460mm at the front, 100mm to the side & 300mm from the rear. This will provide protection from sparks and embers which may fall out from the door when stoking or refuelling. See Fig.7.

Fig.7

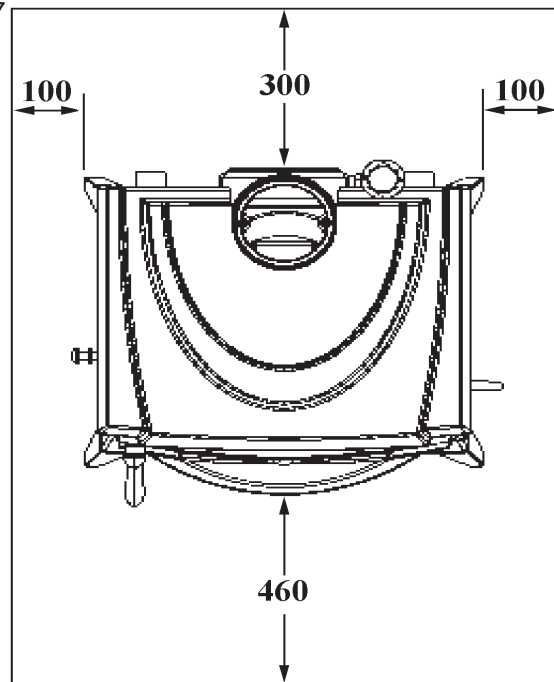

PLUMBING

PIPE THERMOSTAT

The fitting of a pipe thermostat to the flow pipe is essential in order to activate the water circulation pump when the water reaches the selected temperature.

When the water temperature falls below the selected temperature the pipe thermostat will cut off the water circulation pump in order to allow the boiler to recover.

Fig.8

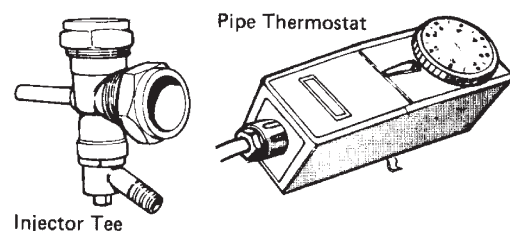

REGULATIONS

The plumbing must be in accordance with all relevant regulations and practices. It must include a gravity circuit with expansion pipe, open to the atmosphere. The central heating will normally be pump-driven as with other types of boilers.

The water system must be properly vented and that a double-feed indirect cylinder to the current issue of BS 1566, Copper indirect cylinders for domestic purposes, Part 1 Specification for double feed indirect cylinders is necessary where there is a combined hot water and central heating system.

GRAVITY CIRCUIT

The gravity circuit consists an indirect domestic hot water cylinder of minimum capacity 135 litres, fixed in an upright position, recommended for hot water storage and it should be connected to the boiler by 28mm diameter flow and return piping. The pipes should not exceed 7.8 meters (25ft) in length and cylinder and pipework should be fully lagged. The shorter the run of pipe work the more effective the water heating. There must be no gate valves on this circuit and it must have an expansion pipe exhausting to atmosphere. Cylinder and pipe work should be lagged to minimise heat loss.

Fig. 9 illustrates the basic principal of water heating systems and must not be regarded as a working drawing.

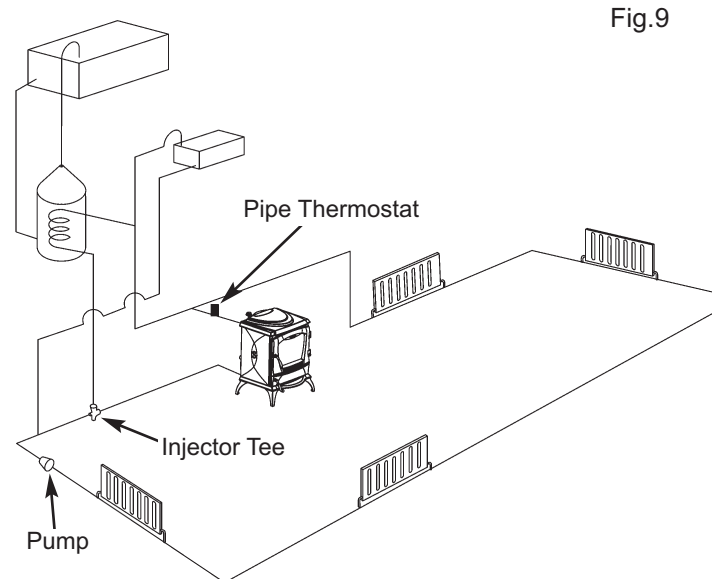

Fig.9

INJECTOR TEE

Where the gravity and central heating circuits join together to return to the stove we recommend the use of an injector tee connection, situated as close to the unit as possible. This type of tee encourages a stable flow of hot water through both circuits and helps to prevent priority being given to the stronger flow, which is most commonly the pumped central heating circuit. This way, there will be no shortage of hot water to the taps when the heating is on.

Where the appliance is to be interlinked with another boiler it will be necessary to use a double feed indirect cylinder in accordance with BS 1566. (See Fig 10 for an illustration)

WATER CIRCUIT TEMPERATURE

The return water temperature should be maintained at not less than 40°C so as to avoid condensation on the boiler and return piping. Fitting a pipe thermostat to the flow pipe of the gravity circuit and wiring it into the pump control will ensure rapid circulation of the hot water.

In some circumstances it may be possible to over-heat the appliance and the water inside will boil. This will be evident by the sound of a knocking noise coming from the appliance and pipes around the house. If this occurs close off all air controls and manually start the central heating pump if fitted. One radiator on the heating circuit should be uncontrolled to act as a heat leak in the event that the appliance overheats and has nowhere to discharge a build up of hot water should the heating circuit be satisfied. Be aware that steam and boiling water will be expended from any open vent from the heating system probably in the roof space at the expansion tank.

In the unlikely event that the appliance is not operating in freezing conditions the water must be drained from the boiler to prevent frost damage.

Fig.10

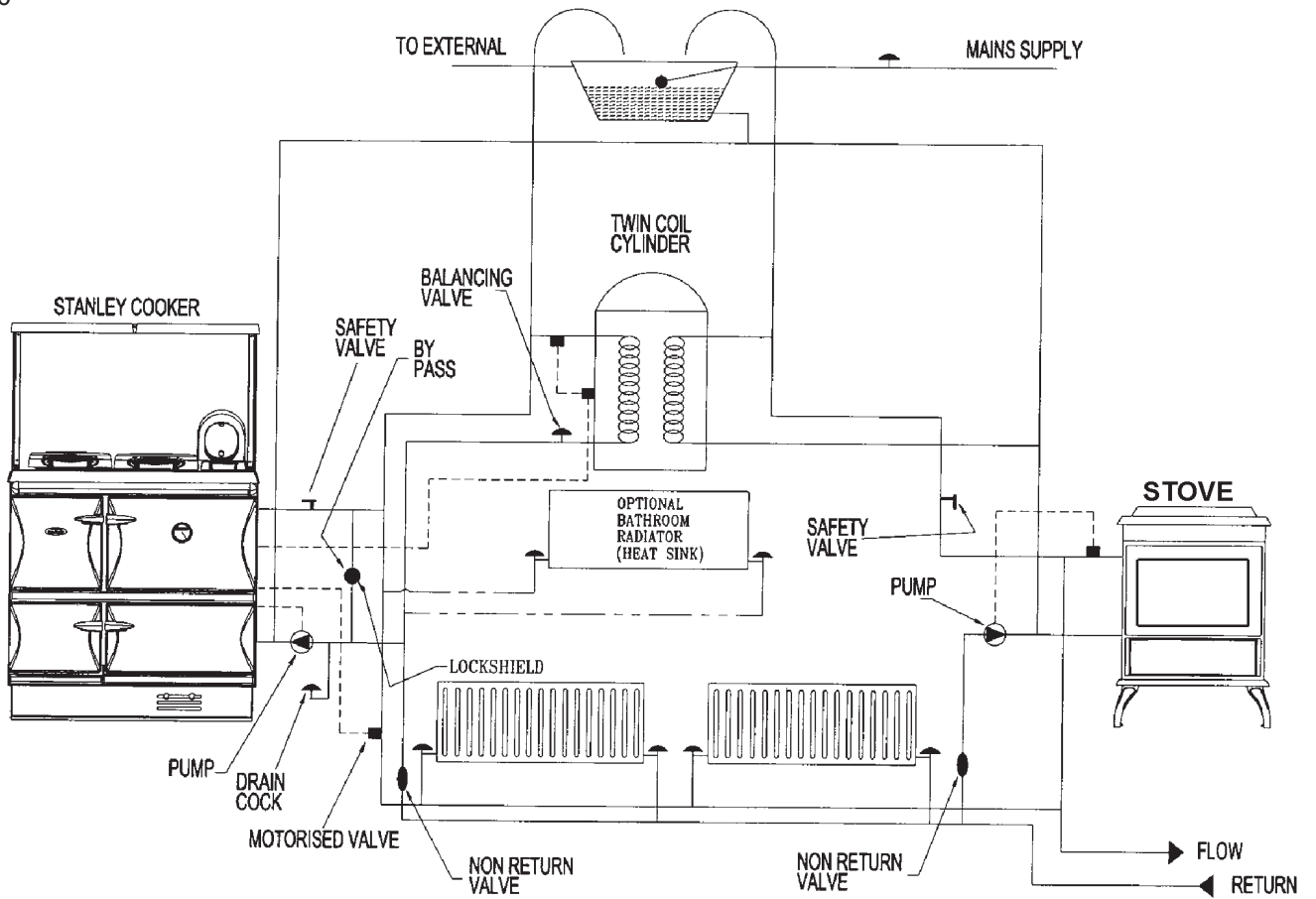

FLUE & WATER PIPE LOCATIONS

Flue outlet to suit 125mm (5") internal diameter flue pipe.

Water outlets 25mm (1") B.S.P.

Fig.11

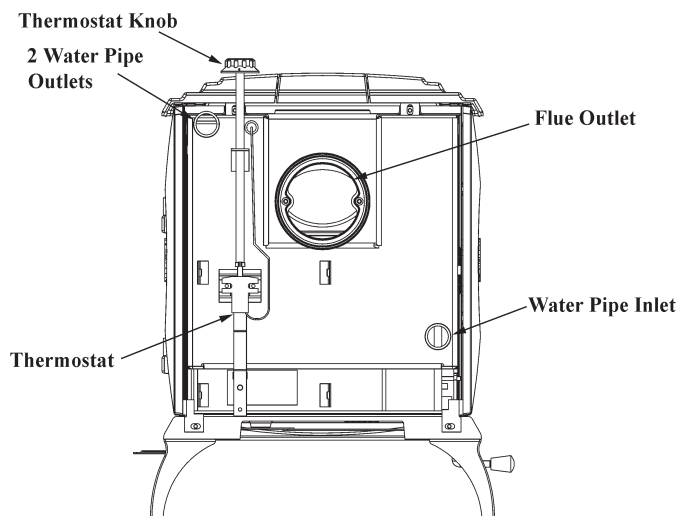

STOVE DIMENSIONS

Fig.12

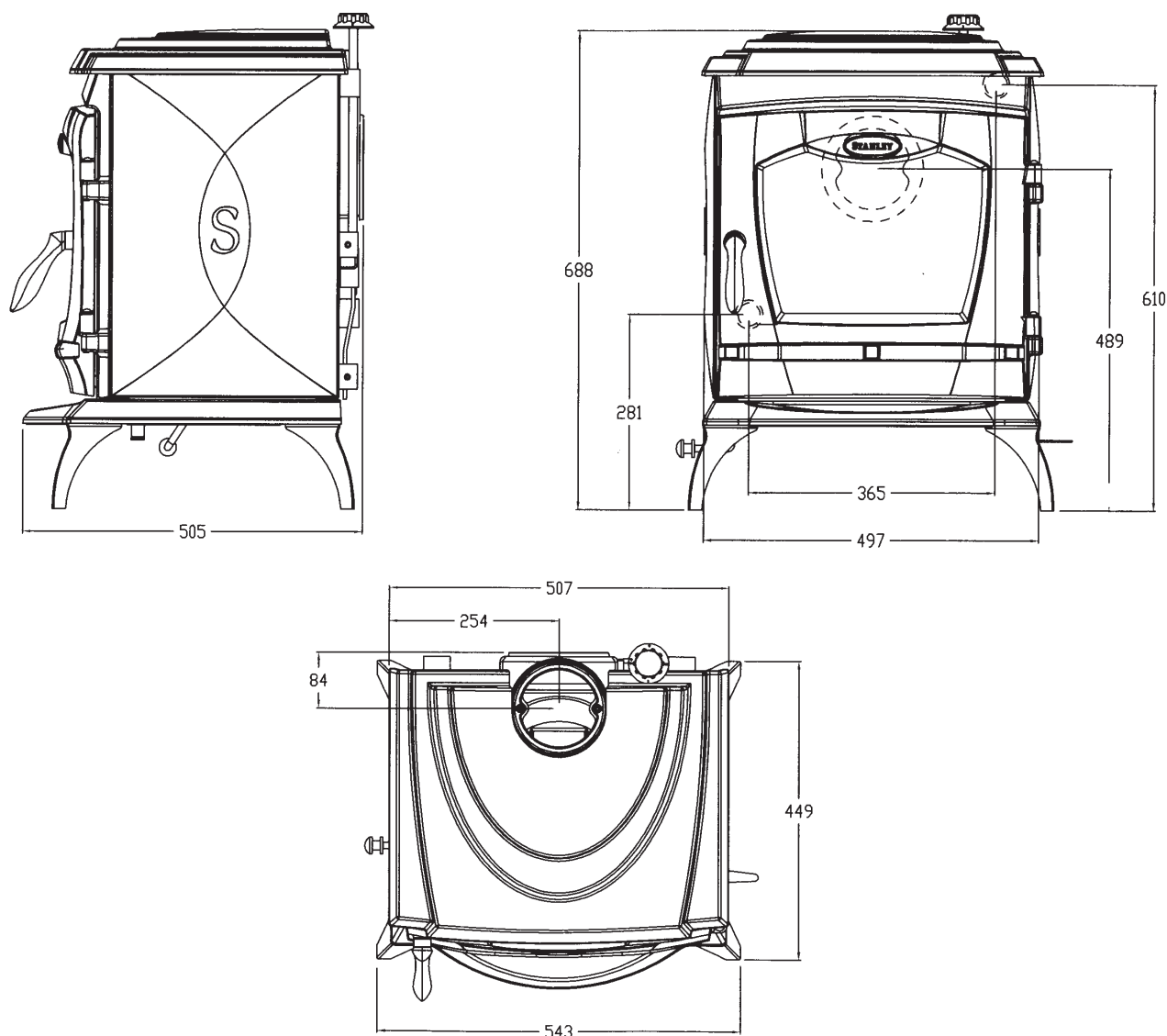

WARNING: DO NOT OBSTRUCT PRIMARY AIR SUPPLY TO THE STOVE

Note: Dimensions stated are in millimetres unless otherwise stated and may be subject to a slight +/- variation.

COMMISSIONING AND HANDOVER

On completion of the installation allow a suitable period of time for any fire cement and mortar to dry out, when a small fire may be lit and checked to ensure the smoke and fumes are taken from the stove up the chimney and emitted safely to the atmosphere. **Do not run at full output for at least 24 hours.**

Ensure that the operating instructions for the stove are left with the customer. Ensure to advise the customer on the correct use of the appliance with the fuels likely to be used on the stove and warn them to use only the recommended fuels for the stove. Advise the user what to do should smoke or fumes be emitted from the stove. The customer should be warned to use a fireguard to BS 8423:2010 in the presence of children, aged and/or infirm persons.

OPERATION

Check that all dampers and catches are operating correctly and ensure that all flue connections are thoroughly sealed.

AIR CONTROLS

The stove has two independent air controls:

1. The thermostat knob (see fig. 13 & 14) which controls the primary air. Rotate clockwise to open and anticlockwise to close.
2. The secondary air control which is located under the base. Push to open and pull to close (see fig. 14)

Fig.13

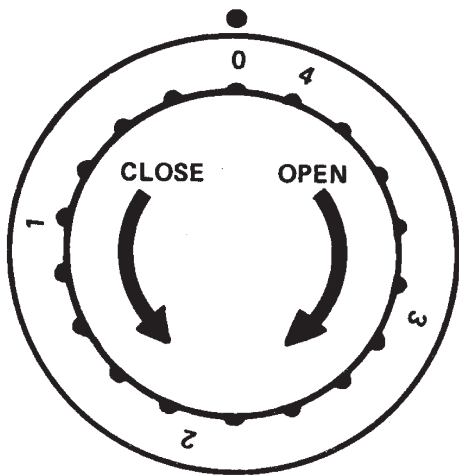
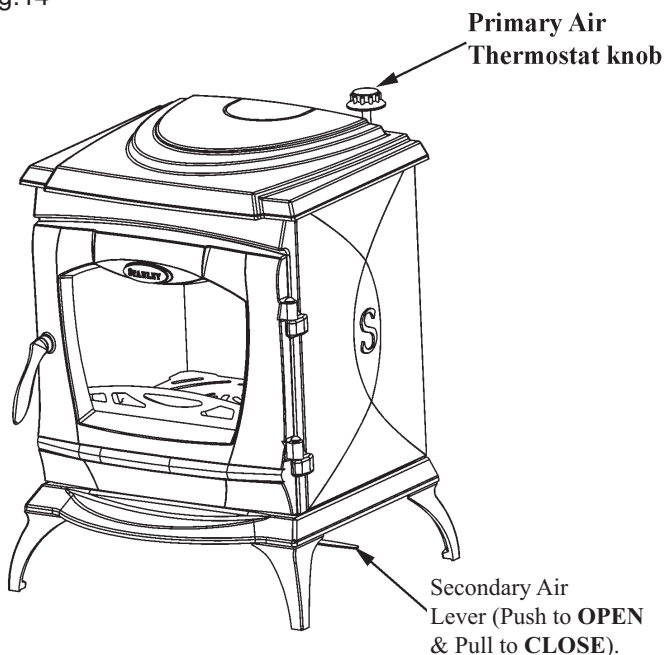

Fig.14



NOTE:-

The controls may become hot when the stove is in operation, use tools or glove provided to adjust the controller when the stove is hot.

A boiler model stove will provide heat into the boiler and also to the room in which it is situated. The heat to room is in a fixed relationship with the heat to the boiler.

The heat to the boiler is controlled by the air supply to the stove which is required to have a thermostatic damper for safety reasons. When the temperature of the water in the boiler exceeds 55 °C the thermostatic damper will begin to shut off the air supply, should the water temperature continue to rise the thermostatic damper will continue to close and if the water temperature reaches 85°C the thermostatic damper closes the primary air supply fully.

In the event where a stove is fitted to a central heating system which is undersized in relation to the nominal heat output to boiler then the stove will operate satisfactorily but will be unable to achieve the nominal heat output to room as the thermostatic damper will shut off the air supply to prevent an over-heat situation in the boiler.

For example:- Where a stove provides 2kW to the room and 8kW to the boiler and if the thermostatic damper shuts down the air supply to provide 4kW to the boiler, then the heat to room will decrease proportionally to 1kW.

RECOMMENDED FUELS

All fuels should be stored under cover and kept as dry as possible prior to use.

This appliance has been tested using seasoned wood logs and manufactured briquetted smokeless fuel (Ancit) for closed appliances, sized between 20g and 140g. Other fuels are commercially available and may give similar results. Wood logs up to 380mm long are suitable. All fuels should be stored under cover and kept as dry as possible prior to use.

Do not use fuels with a Petro-coke ingredient as this may cause the grate to overheat, causing damage. Reduced outputs will result when fuels of lower calorific values are used. Never use gasoline or gasoline type lantern fuel, kerosene, charcoal lighter fluid or similar liquids to start or freshen up a fire in this heater. Keep all such liquid well away from the heater at all times. Operate the stove only with the fuelling door closed except for re-fuelling.

This stove has obtained HETAS Ltd approval for burning natural and manufactured smokeless fuels only as detailed in recommended fuels below. HETAS Approval does not cover the use of other fuels either alone or mixed with the recommended fuels listed, nor does it cover instructions for the use of other fuels.

TECHNICAL DATA						
	MANUFACTURED SMOKE-LESS FUEL			WOOD		
	Room	Water	Total	Room	Water	Total
Max Output: (kW)	3.5	8.5	12	4	6	10
Nominal Output: (kW)	2.6	8.5	11.1	2.8	5.8	8.6
Typical refuelling intervals to obtain nominal outputs:	MSF 1 hr			WOOD 1 hr		
Flue Gas Mass Flow:	7.4g/s			6.9g/s		
Flue Gas Temperature at nominal output:	363°C			301°C		
Gross Weight:	155 kgs					
Flue Outlet Diameter:	125mm					
Flue Draught:	12 Pa					
Boiler Capacity:	9.5 Litres					
Boiler Tappings:	1" BSP					
Max Water Pressure:	2 Bar					
Efficiency:	72.8 %			74.5%		
Log Size:	340mm			340mm		

Model	Energy Efficiency Class	Heat Output to Room	Heat Output to Water	Energy Efficiency Index	Preferred Fuel	Nominal Heat Output	Net Efficiency
Ardmore HPB SF Stove	A	2.8	5.8	99.03	Wood	8.6	74.5

LIGHTING

Before lighting the stove check with the installer, that the installation work and commissioning checks described previously have been carried out correctly and the chimney has been swept clean, is sound and free from any obstructions. As part of the stove commissioning and handover the installer should demonstrate how to operate the stove correctly.

USER INSTRUCTIONS

LIGHTING THE STOVE

1. Open fire door and open the primary air inlet by turning the control knob on the back of the stove fully clockwise to setting 4 on the thermostat.
2. Open the secondary air inlet by pushing it fully back.
3. Cover the grate with crumpled pieces of paper and lay 10-12 pieces of kindling on top of the paper towards the back of the firebox.
4. Ignite and close the fire door.
5. When the kindling is well alight open the fire door and add more kindling of a larger size to sustain the fire.
6. Close the fire door.
7. When a hot fire bed is established add the normal fuel.
8. When well lighted, adjust the controls to give the required heat output.

REFUELLING

Riddle the fire by pulling the grate riddling knob back and forward (See Figure 15). Before opening the door, turn the thermostat knob to setting 4 as this will help to eliminate any smoke or fly ash resident in the combustion chamber. Add fuel to fire, close fire door and re-set the thermostat knob to the required setting.

SLOW BURNING

Slow burning will cause the window glass to blacken and should not be used for a long period. It should only be done after the fire has been established and been funning at nominal output for a period of time. For a prolonged show burn, fill the firebox of fuel up to the maximum height just below the top of the fire fence at the front of the door opening. Close the secondary air knob fully and set the thermostat knob to 0-1/2.

Fig.15

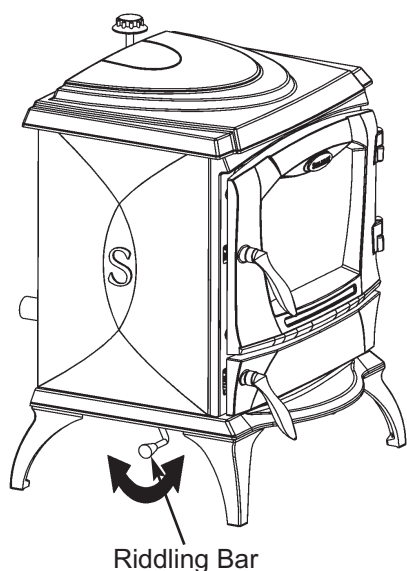

DE-ASHING

When ash build-up becomes excessive in the fire chamber shake the firebars by pushing and pulling the riddling rod repeatedly. The riddling rod is located under the base at the left side of the stove.

DISPOSAL OF ASHES

Your stove is provided with a steel ashpan. This ashpan should be emptied every day.

If ashes are allowed to build to grate level you could damage the firebars by overheating. We recommend that you remove ashes after you have riddled the fire following overnight burn.

Ashes should be placed in a metal or other non-combustible container with a tight fitting lid. The closed container of ashes should be placed on a non-combustible material, pending final disposal. If ashes are buried in soil, or otherwise dumped they should be retained in the closed container until they are thoroughly cooled. Open the fire door and remove the ashpan using the tool provided, see Fig. 16. Close the fire door. When the ash is disposed of replace the ashpan.

REMEMBER COAL GASES ARE TOXIC

Fig.16

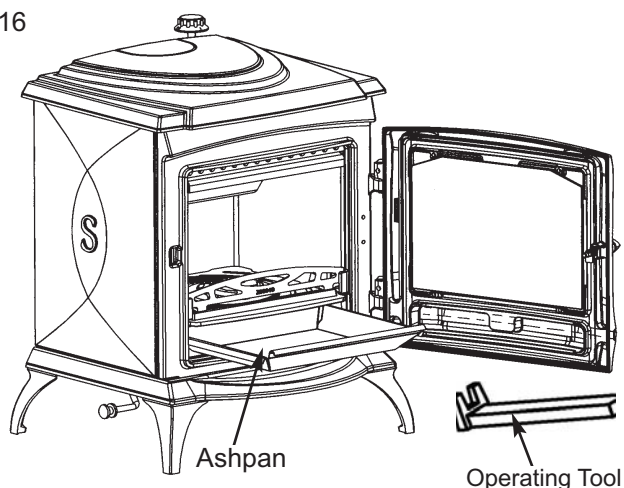

MONTHLY MAINTENANCE

Cleaning Stove Flue Pathways

It is recommended that the flue pathways in the stove are cleaned on a monthly basis (or less depending on the soot build-up created by the fuel being used) and the chimney cleaned annually. When cleaning the flue pathways the boiler cleaning plate should be removed by lifting up the cleaning plate & pulling it forwards until it clears the boiler (see Figure 17). Remove any build-up of soot on the top of the boiler using a suitable cleaning brush and when finished replace the boiler cleaning plate. The boiler cleaning plate can also be removed when cleaning the chimney if the flue pipe is fitted to the back outlet.

Fig 17

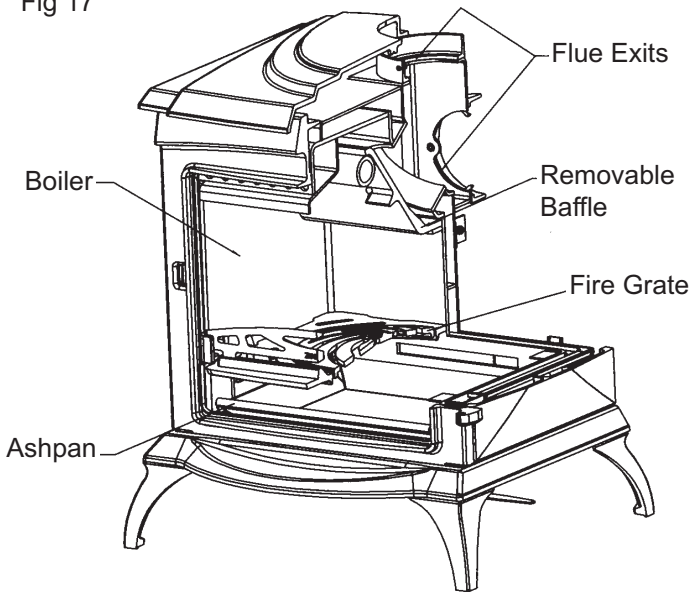
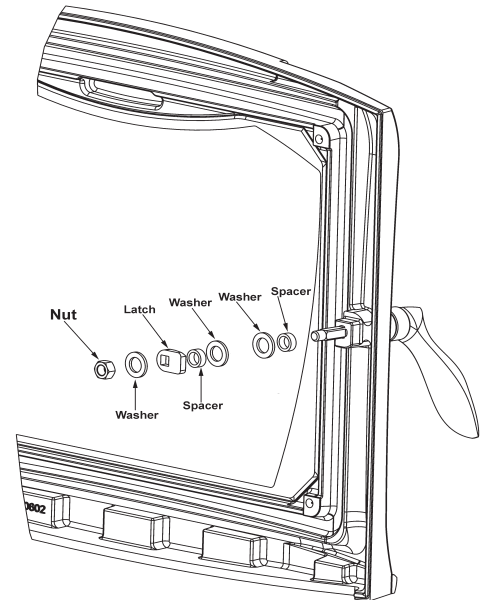

Fig 19



MONTHLY MAINTENANCE

Adjusting the Door Catch

Over time, the fire door latch can loosen due to the continual compression and hardening of the rope seal between the door and the front casting. The position of the latch can be easily adjusted (in order to tighten the door closure) by removing the nut holding on the door latch and repositioning the washers between the latch & the door casting to allow the latch to be positioned closer to the back of the door casting - see Fig. 18 & 19. The tightness of the door seal should be checked after each adjustment is made. It is recommended that the rope seals on the stove are changed at least every two years or sooner if the seal loses its integrity.

Fig 18

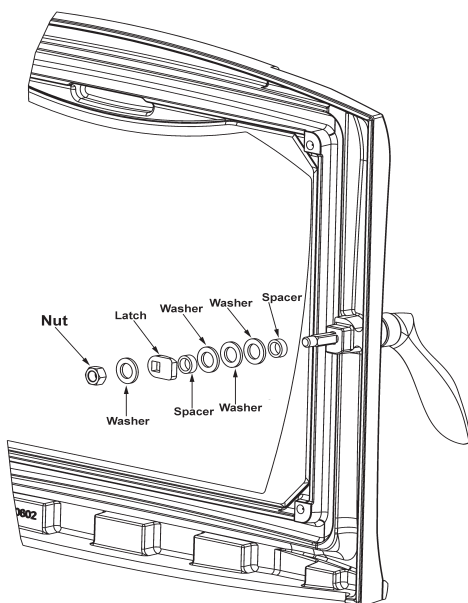

CHIMNEY CLEANING

The chimney should be cleaned twice annually or if the stove is not used for a prolonged period during the summer period, it should be cleaned prior to commencement of usage. The chimney can be cleaned through the stove depending on the flue configuration and the flue liner should be cleaned in accordance with manufacturer's instructions. Always use a brush with plastic bristles that is the correct size to reach all areas of the flue.

GLASS CLEANING

The stove glass will self-clean when there is sufficient heat generated by the burning fuel i.e. when the unit is operated at the maximum air settings. If a build-up of creosote occurs on the glass it may be due to low draft conditions, poor quality fuel or operating the stove at the minimum air settings for long periods of time. The glass should be cleaned when cool and cleaned with a non-abrasive cloth using warm soapy water. For stubborn deposits, a grade 0 steel wool can be used whilst taking care not to scratch the glass with any coal/ash deposits.

VITREOUS ENAMEL CLEANING

General cleaning must be carried out when the stove is cool.

If this stove is finished in a high gloss vitreous enamel, to keep the enamel in the best condition observe the following tips:

1. Wipe over daily with a soapy damp cloth, followed by a polish with a clean dry duster.
2. For stubborn deposits a soap impregnated pad can be carefully used on the vitreous enamel.
3. Use only products recommended by the Vitreous Enamel Association, these products carry the Vitramel label.

A detailed list of the approved cleaners can be found on their website www.vea.org.uk/enamel-care/

DO NOT USE ABRASIVE PADS OR OVEN-CLEANSERS CONTAINING CITRIC ACID ON ENAMELLED SURFACES. ENSURE THAT THE CLEANSER MANUFACTURERS INSTRUCTIONS ARE ADHERED TO.

NOTE: Small impact marks on the enamel finish can be repaired using an appropriate enamel touch up (a touch up bottle is included with the stove packaging) but it should not be used to cover marks greater than $\varnothing 10\text{mm}$ or multiple marks on the same casting/area.

CLEANING A MATT BLACK/SENOTHERM STOVE

Cleaning should be done when the stove is cold by removing any dust or dirt using a dry cloth. Do not use any water on the matt black/senotherm finish as this will cause it to rust.

FROZEN SYSTEM

If there is any possibility that the water system may be frozen do not attempt to light the stove until you are certain there is no ice in the system possibly causing a blockage.

PROLONGED PERIODS OF NON USE

If the stove is to be left unused for a prolonged period of time then it should be given a thorough clean to remove ash and unburned fuel residues. To enable a good flow of air through the appliance to reduce condensation and subsequent damage, leave the air controls fully open.

It is important that the flue connection, any appliance baffles or throat plates and the chimney are swept prior to lighting up after a prolonged shutdown period.

WARNING NOTE:

Properly installed, operated and maintained this stove will not emit fumes into the dwelling. Occasional fumes from the de-ashing and re-fuelling may occur. However, persistent fume emission is potentially dangerous and must not be tolerated. If fume emission does persist, then the following immediate action should be taken:

- (a) Open doors and windows to ventilate room.
- (b) Let the fire out or eject and safely dispose of fuel from the stove.
- (c) Check for flue or chimney blockage and clean if required.
- (d) Do not attempt to relight the fire until the cause of the fume emission has been identified and corrected. If necessary seek expert advice.

The most common cause of fume emission is flue-way or chimney blockage. For your own safety these must be kept clean at all times.

FIRE SAFETY

To provide reasonable fire safety, the following should be given serious consideration.

1. Do not over fire the stove.
2. Over-firing will also damage painted or enamel finish.
3. Install a smoke detector in the room.
4. A conveniently located class A fire extinguisher to contend with small fires resulting from burning embers.
5. A practical evacuation plan.
6. A plan to deal with a chimney fire as follows:-
 - (a) Notify the fire department.
 - (b) Prepare occupants for immediate evacuation.
 - (c) Close all openings into the stove.

(d) While awaiting the fire department watch for ignition to adjacent combustibles from overheated flue pipe or from embers or sparks from the chimney.

GLASS REPLACEMENT

- (a) Open the fire door fully.
- (b) Remove the four corner screws and clips and carefully remove the broken glass.
- (c) Clean the glass recess in the door.
- (d) Replace the sealing rope in the door if necessary
- (e) Tighten screws.
- (f) Replace glass only with ceramic glass 5mm thick. (See Fig 20).

Fig. 20

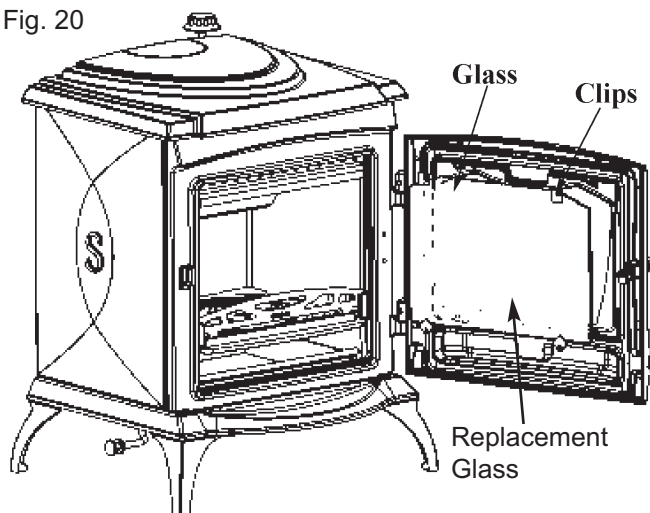

CO ALARM

The fitting of CO Alarms in the same room as the appliance is a compulsory requirement under current Building Regulations. For ROI an additional CO Alarm must be fitted either inside each bedroom or within 5 metres of the bedroom door, refer to Building Regulations Part J. Further guidance on the installation of a carbon monoxide alarm is available in BS EN 50292:2002 and from the alarm manufacturers instructions.

Provision of an alarm must not be considered a substitute for either installing the appliance correctly or ensuring regular servicing and maintenance of the appliance and chimney system.

WARNING:-

If the CO Alarm sounds unexpectedly:-

1. Open Doors and windows to ventilate the room and then leave the premises.
2. Let the fire go out.

ARDMORE SF BOILER EXPLODED VIEW

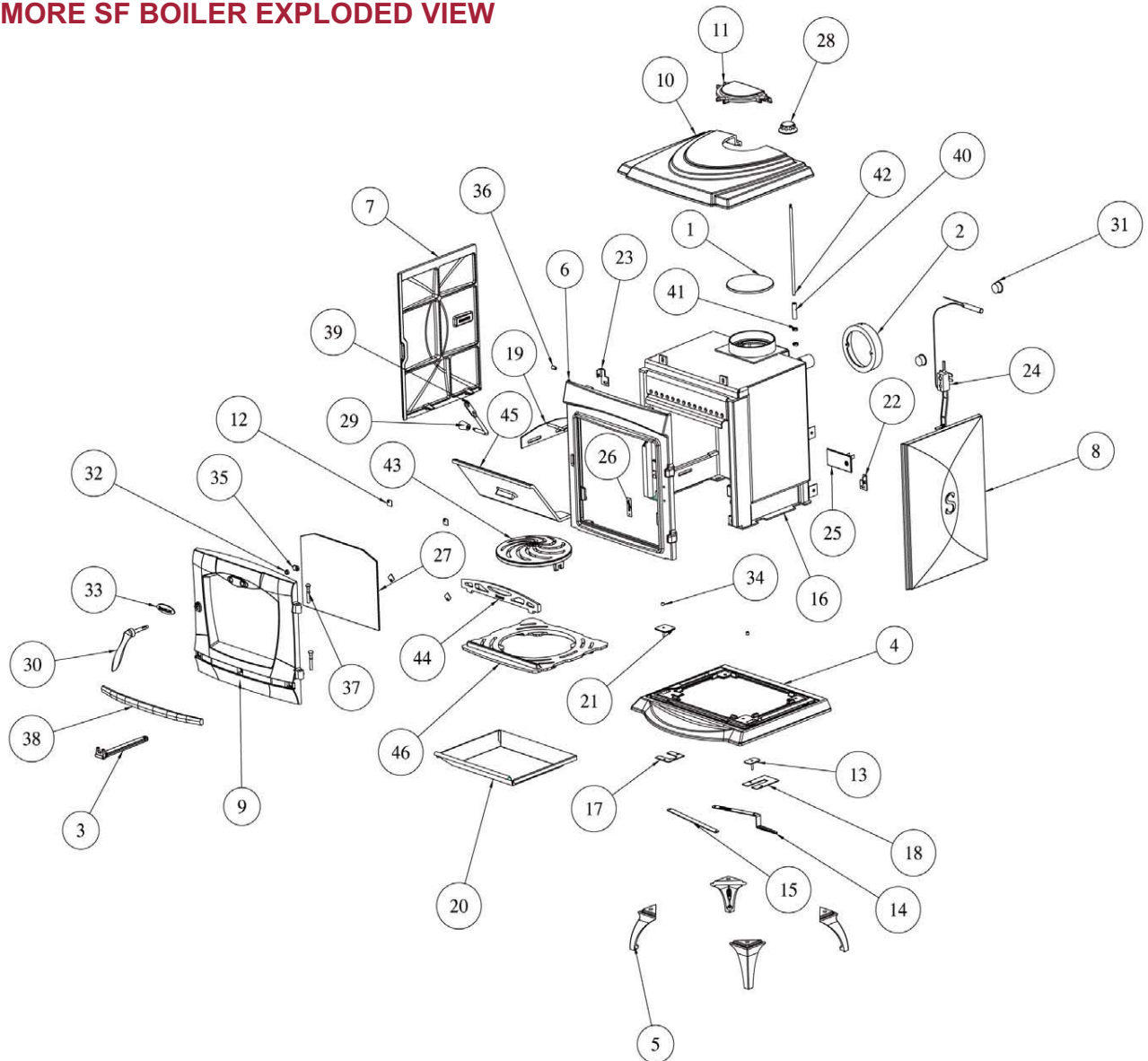

- | | |
|--|---|
| 1. FLUE BLANKING PLATE - B0006AXX | 26. SERIAL NUMBER PLATE - N00234BXX |
| 2. FLUE SPIGOT - B00007BXX | 27. GLASS - T00102AXX |
| 3. OPERATING TOOL - B00009DXX | 28. AIR CONTROL KNOB - U00006AXX |
| 4. BASE - B00620AXX | 29. SECONDARY AIR CONTROL - U00018AXX |
| 5. STOVE LEG - B00621AXX | 30. DOOR HANDLE - U00191AXX |
| 6. FRONT - B00622AXX | 31. BOILER PLUG - V00016AXX |
| 7. LEFT HAND SIDE - B00623AXX | 32. SPACER TO DOOR HANDLE - V00035AXX |
| 8. RIGHT HAND SIDE - B00624AXX | 33. BADGE - V00912AXX |
| 9. FIRE DOOR - B00625AXX | 34. SPACER - V00956AXX |
| 10. HOB - B00626AXX | 35. DOOR CATCH - V00985AXX |
| 11. HOB FILLER PIECE - B00629AXX | 36. SPACER - V00991AXX |
| 12. DOOR GLASS CLIP - F00003AXX | 37. HINGE PIN (CAM ACTION) - V00997AXX |
| 13. DAMPER PLATE RH - F01109AXX | 38. FRONT STRIP - V01008AXX |
| 14. DAMPER LINK SHORT - F01110AXX | 39. RIDDLING ROD - V01011AXX |
| 15. DAMPER LINK LONG - F01111AXX | 40. RUBBER EXTENSION - V01026AXX |
| 16. BOILER - F01117AXX | 41. CONSTANT TENSION CLAMP - V01027AXX |
| 17. COVER PLATE LH - F01118AXX | 42. THERMOSTAT CONTROL ROD - V01029AXX |
| 18. COVER PLATE RH - F01119AXX | 43. GRATE - Z00036AXX |
| 19. RIDDLING LINK - F01120AXX | 44. FIRE FENCE - Z00049AXX |
| 20. ASHPAN - F01130AXX | 45. CLEANING DOOR - Z00060AXX |
| 21. DAMPER PLATE LH - F01151AXX | 46. GRATE SUPPORT PLATE - Z00061AXX |
| 22. SIDE PANEL BRACKET RH - F01152AXX | |
| 23. SIDE PANEL BRACKET LH - F01153AXX | |
| 24. THERMOSTAT - G00479AXX | |
| 25. THERMOSTAT DAMPER PLATE - F01132AXX | |

NOTES

NOTES

Manufactured by
Waterford Stanley Ltd.,
Unit 401-403, IDA Industrial Estate, Cork
Road, Waterford, Ireland.
Tel: (051) 302300 Fax (051) 302315

