

Gasbox Full Rigid Frames 1957-2003 Harley Davidson Sportsters- Disc Rear Brake

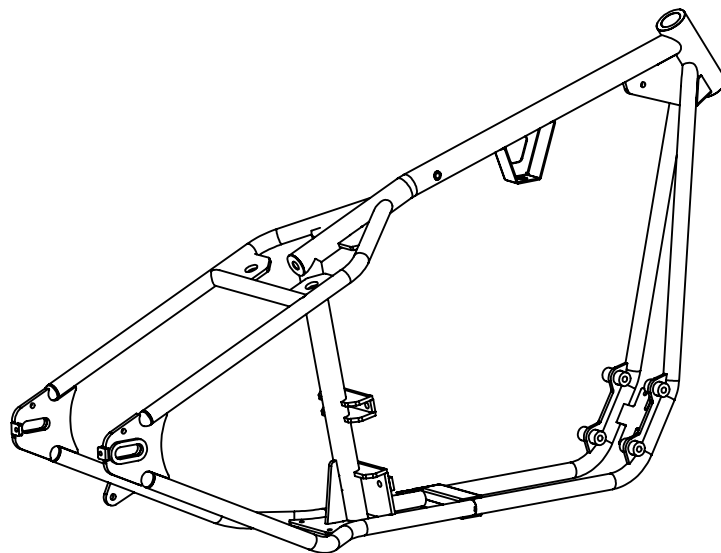

For 1957-2003 Harley-Davidson Sportster Engines

- Includes MSO (Manufacturer's Statement Of Origin).
 - Highest Quality Available With Perfect Fit And Finish.
 - Made In Cleveland, Ohio, USA.
-
- Gasbox #A-2000 (Lowbrow Customs #013387) 1957-1985 Ironhead Engines. Frame has standard height steering neck. (1982-1985 Ironhead Sportster engines require rear motor mount Harley OEM #16203-67.)
 - Gasbox #A-2050 (Lowbrow Customs #013388) 1957-1985 Ironhead Engines. Frame has +3" height steering neck and straight backbone. (1982-1985 Ironhead Sportster engines require rear motor mount Harley OEM #16203-67.)
 - Gasbox #A-2000 (Lowbrow Customs #013389) 1986-2003 Evo Sportster Engines. Frame has standard height steering neck.
 - Gasbox #A-2000 (Lowbrow Customs #013515) 1986-2003 Evo Sportster Engines. Frame has +3" height steering neck and straight backbone.



The Gasbox full frames are the highest quality and best engineered available. This frame allows direct bolt-in fitment for 1957-1985 Harley Ironhead Sportster or 1986-2003 Evo Sportster engines. All 1 inch tubing, completely TIG welded and made in Cleveland, Ohio, USA.

Unlike other custom frames, the Gasbox frames uses stock motor mounts all around, with the engine cradled low in the frame rails just like a stock bike. This looks much cleaner and keeps the finished chopper looking lean and handling better with a lower center of gravity. This frame also accepts the stock early style kickstand H-D #50062-52A. The neck has a 32 degree rake and is in the stock location, is set up for a 1" stem, and utilizes 1" stem Timken style neck cups. This stem size is very common and is found on narrow glide front ends on Sportsters 1982 and later, and on Harley Big Twin front ends, including narrow glide, wide glide, OEM and most aftermarket springer front ends.

The rigid rear hardsail section has approximately 4 inches of stretch and is set up to have 2 inches of drop. This means that with a front end and wheels on the bike the lower frame rails sit 2 inches closer to the ground than stock for that perfect stance. The axle plates are set up for a standard 3/4 inch rear axle and accepts a stock disc brake Sportster rear axle. This frame also features integrated upper mounts for Horseshoe Oil Tank #010404 and integrated bracket for the stock rectifier. Lowbrow Customs Rear Chain Adjusters for 3/4 inch axles are a perfect fit with this frame. This frame is designed for use with disc brake rear wheels, it will not work with stock, early ironhead drum brake wheels. Sportster disc brake rear wheels are a perfect fit, as are Cycle Standard 16 x 3.00 inch rear wheels, such as the Lowbrow Customs Black #010383 or Chrome #010382 wheels.

Each frame will receive an MSO (Manufacturer's Statement of Origin) sent separately in the mail directly from The Gasbox. This will have the frame's individual serial number-VIN number (stamped into the neck of the frame) as well as the purchaser's information. This is needed in most places when titling a custom motorcycle.



ALL PARTS AVAILABLE AT:
www.lowbrowcustoms.com

Frame Features



- The frame has mounting for early Sporster gas tanks with 16-5/8" spacing.
- Frame backbone is 1-1/2" diameter to fit many other chopper tanks.
- The frame has tab to fit early Sporster kickstands H-D #50062-52A.
- The front frame cross brace has integrated mounting tabs for the stock rectifier.

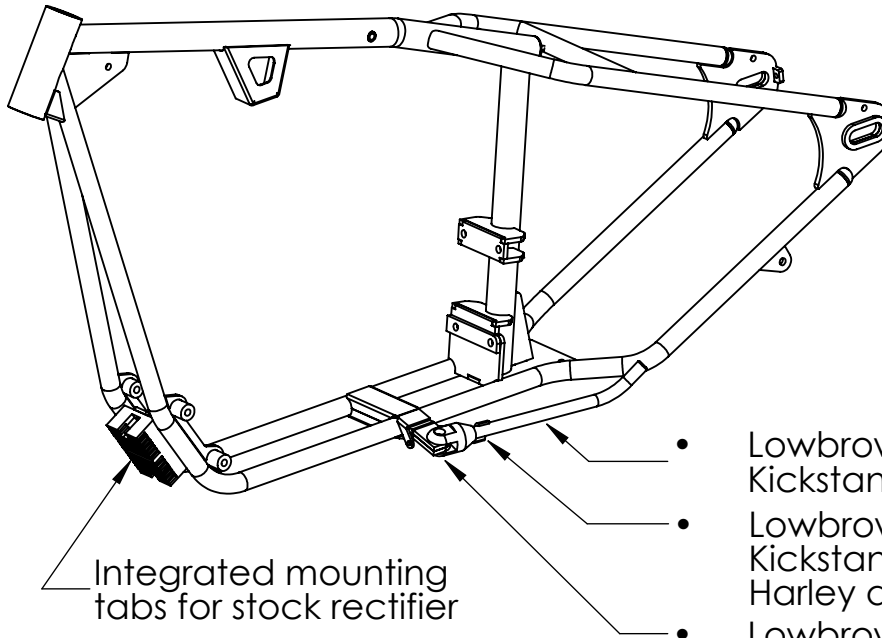

Integrated mounting tabs for stock rectifier

- Lowbrow Customs #013767 Kickstand.
- Lowbrow Customs #008166 Kickstand Spring 1936-1987 Harley davidson
- Lowbrow Customs #005746 Kickstand Mounting Pin and Screw

- Lowbrow Customs #007587 H-D Ironhead Sporster 1958-1978 Gas tank.

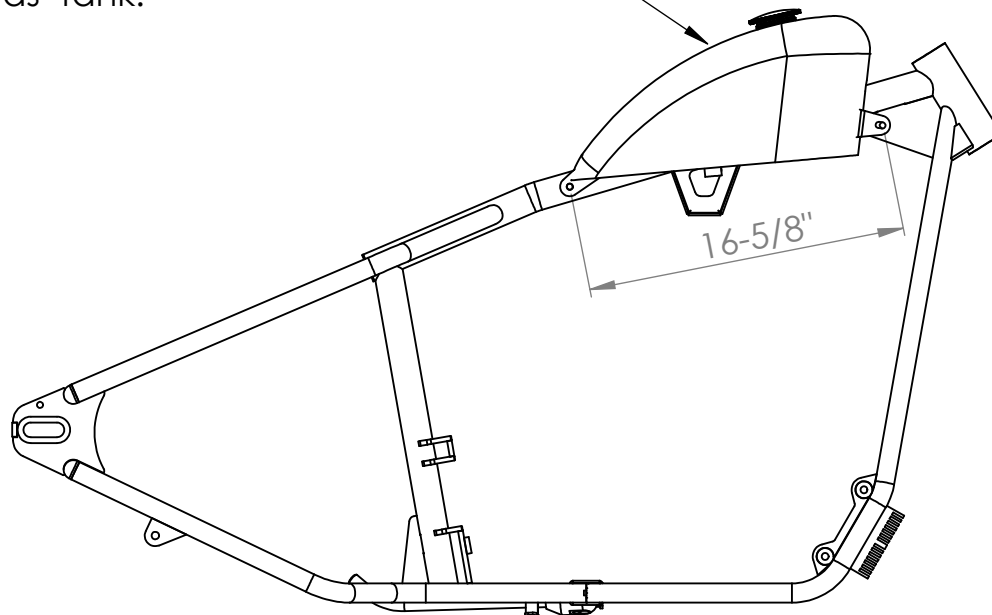

Engine Mounting



- Install all bolts, washers and nuts finger tight first to check fit and alignment.
- Tighten the rear engine bolts first, then the front engine mount plate bolts second.
- The top engine mount will require custom spacing to close the gap. Use spacers or washers as required.
- Use lock nuts or thread lock on all bolts.

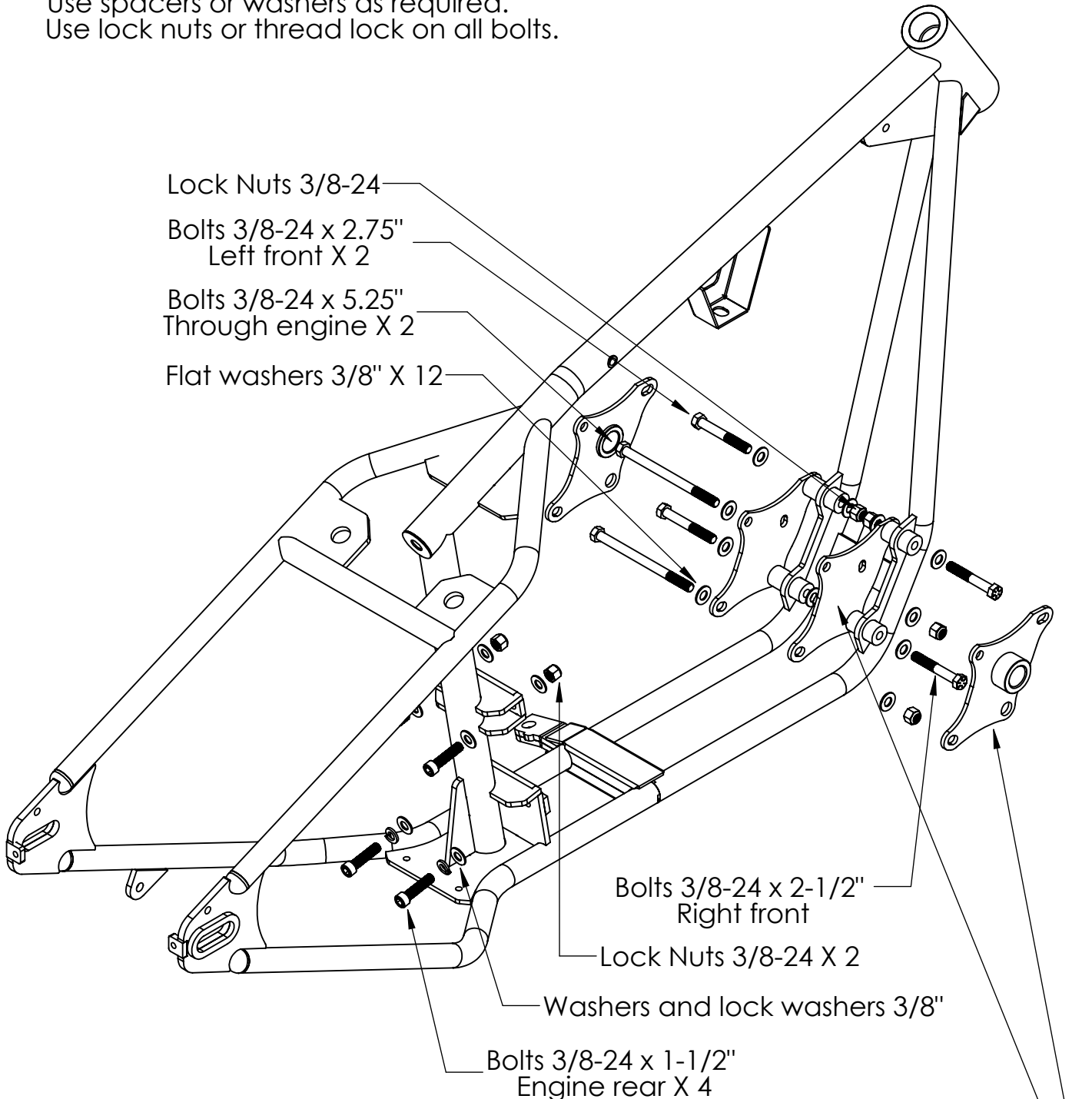

Front engine plates use the early Harley type.

- Gasbox #009773 Parkerized black. (H-D #16210-52)
- Gasbox #005585 Stainless.
- Gasbox #009772 with oil filter mount, parkerized black. (H-D #16210-81)
- Gasbox #A-22041 With footpeg mounts.

ALL PARTS AVAILABLE AT: www.lowbrowcustoms.com



Ironhead Top Motor Mount

- The top engine mount will require custom spacing for best fitment. Use spacers or washers as required.
- Use lock nuts or thread lock on all bolts.

- Gasbox #009245 XL Motor Mount with coil and crank start mounts.
- Mount location for Lowbrow Customs #002732 Weatherproof Starter Ignition Key Switch.

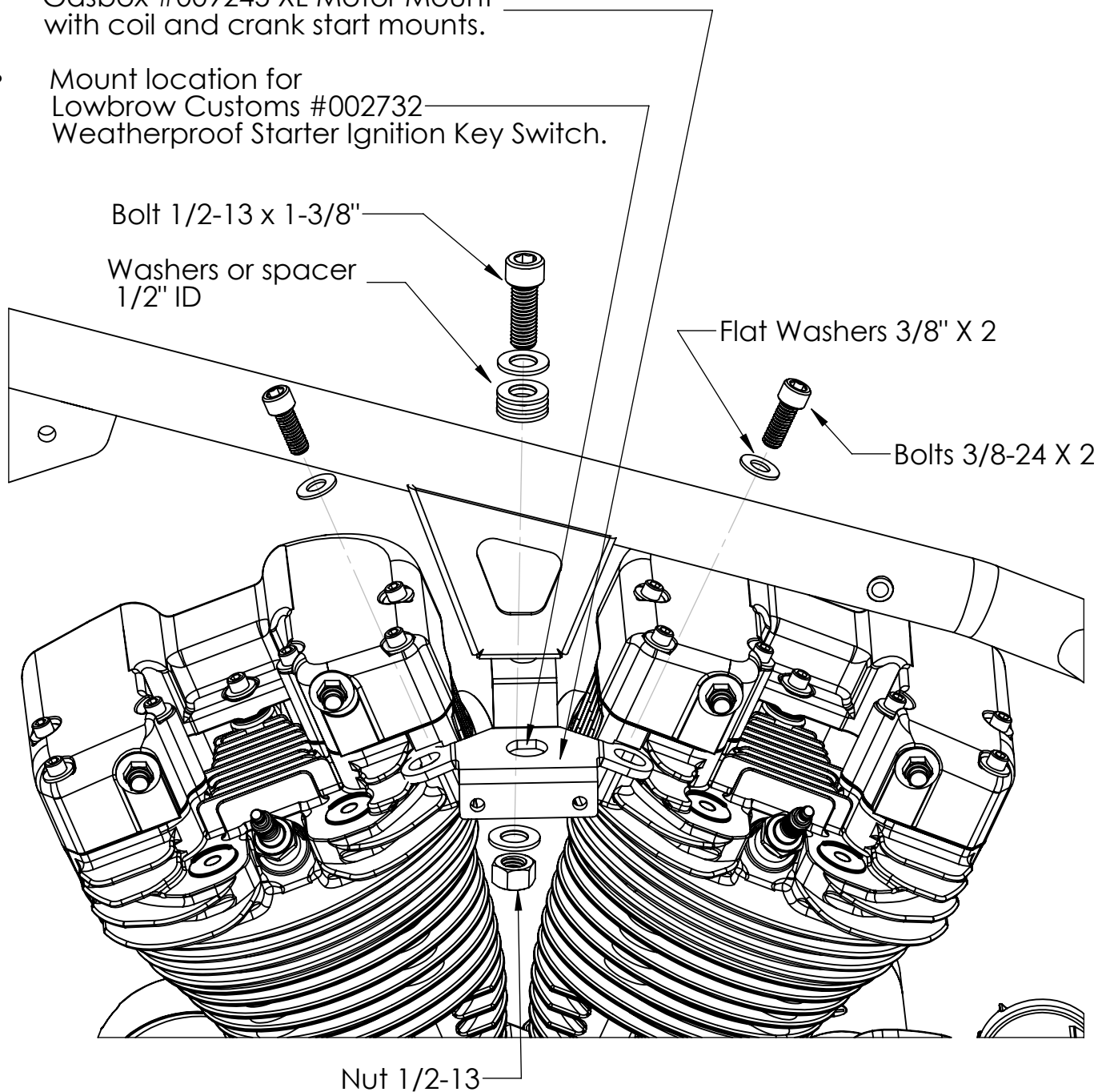

Evo Top Motor Mounts

- Use the spacer plate between frame and motor mount. (Supplied with frame)
- Use lock nuts or thread lock on all bolts.
- Gasbox #003998 Top Motor Mount with coil and stock ignition switch mounts- Black.
- Gasbox #011892 Top Motor Mount with coil and stock ignition switch mounts- Stainless.

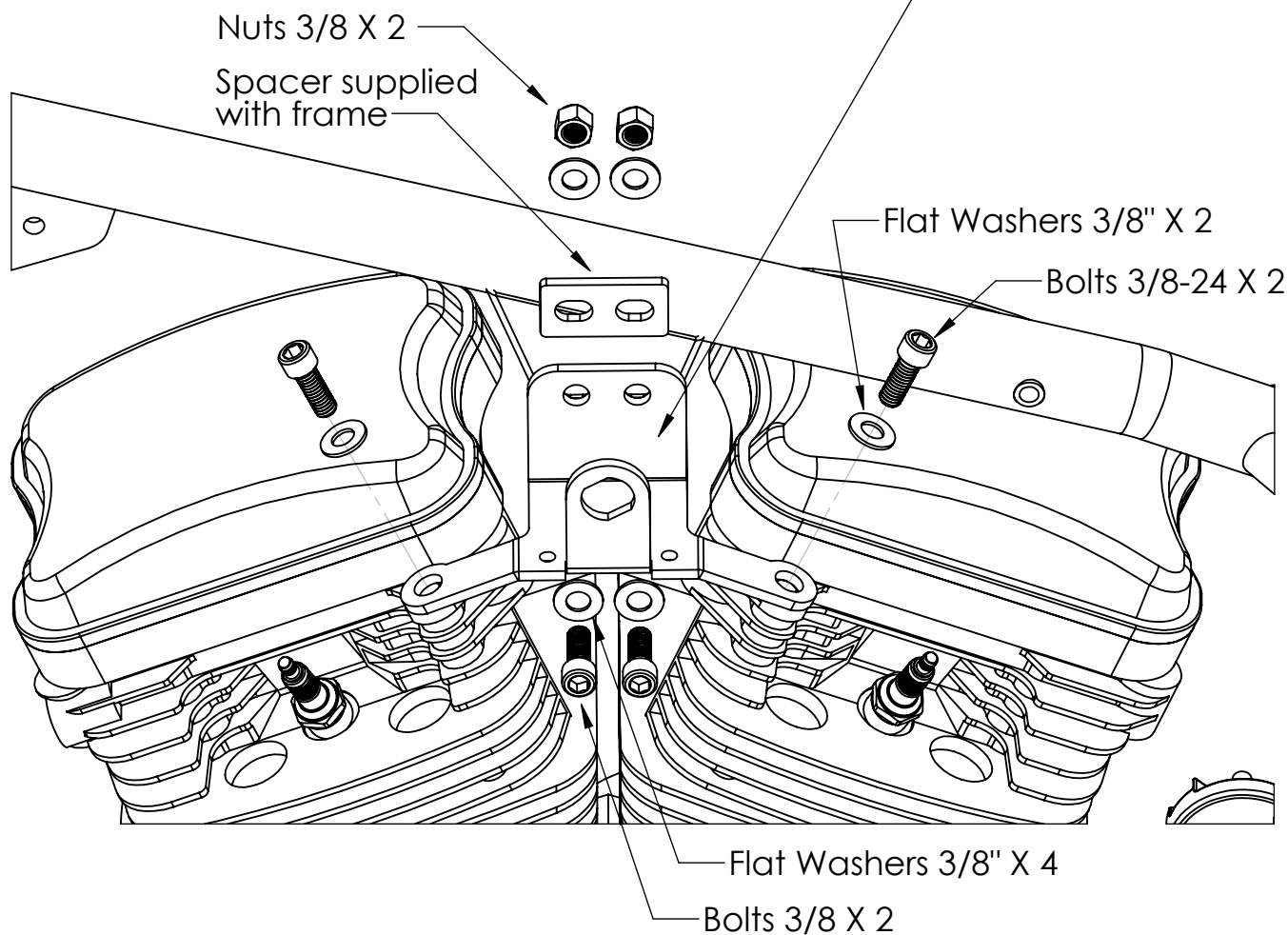

- Gasbox #010336 Top Motor Mount with ignition coil relocation- Black.
- Gasbox #011893 Top Motor Mount with ignition coil relocation- Stainless.

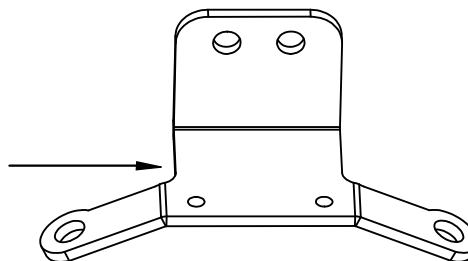

Triple Clamps

- The steering neck uses bearing cups for 1" diameter H-D steering stems.

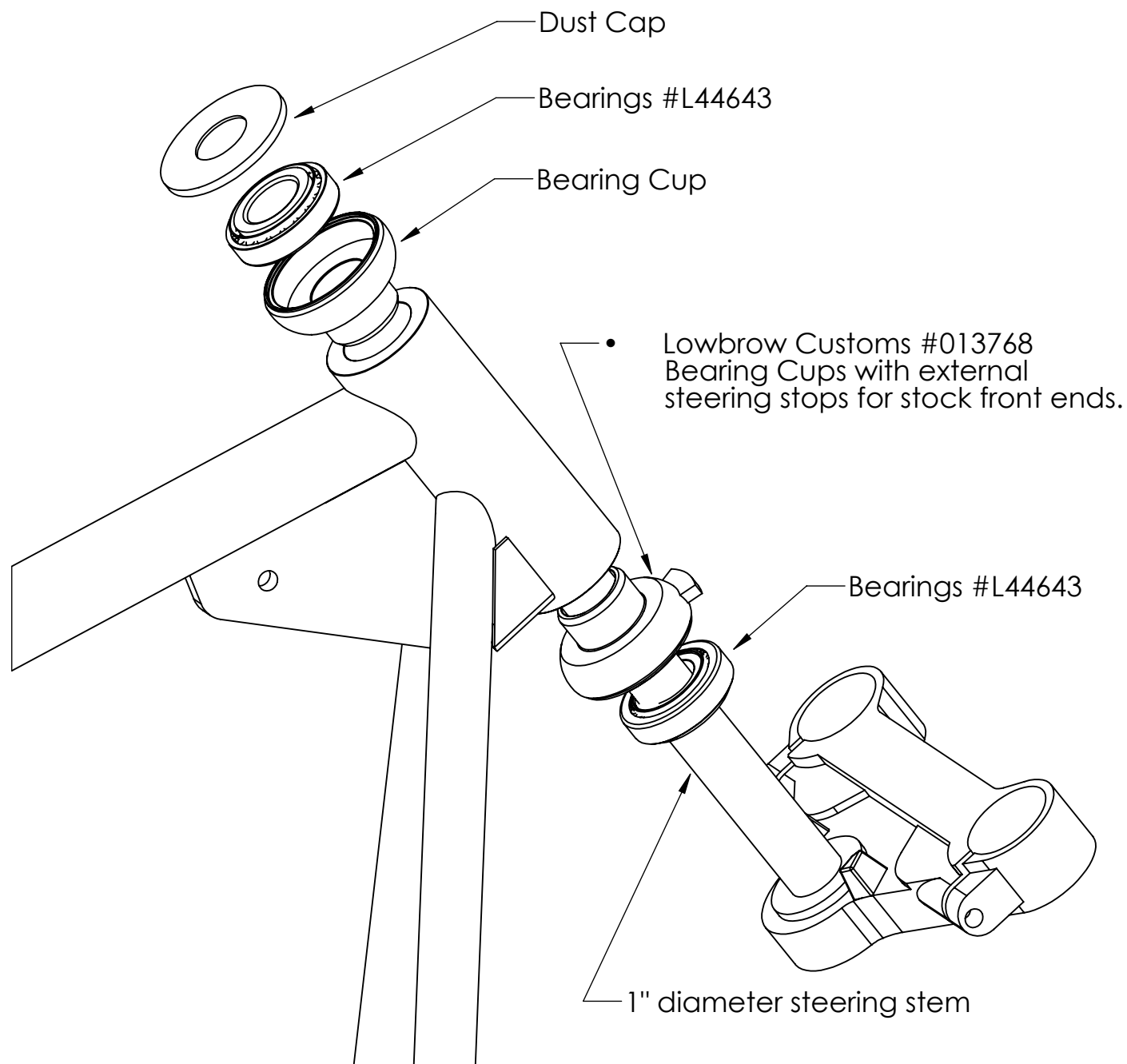

Rear Wheel and Brake



- The rear axle plates uses a 3/4" axle.
- Axle plates inside width is 9-1/2".
- Center the rear wheel in the frame with suitable 3/4" axle spacers.
- Use lock nuts or thread lock on all brake components.

- 16" X 3" Complete Rear Wheel Chrome
Lowbrow Customs #010382.
- 16" X 3" Complete Rear Wheel Black
Lowbrow Customs #010383.

Ironhead Sportster

- Lowbrow Customs #013769
Flat Rear Sprocket 51 Tooth.

Evo Sportster

- Lowbrow Customs #013770
Dish Rear Sprocket 51 Tooth.

- Lowbrow Customs #001773
3/4" Axle Adjusters Chrome.

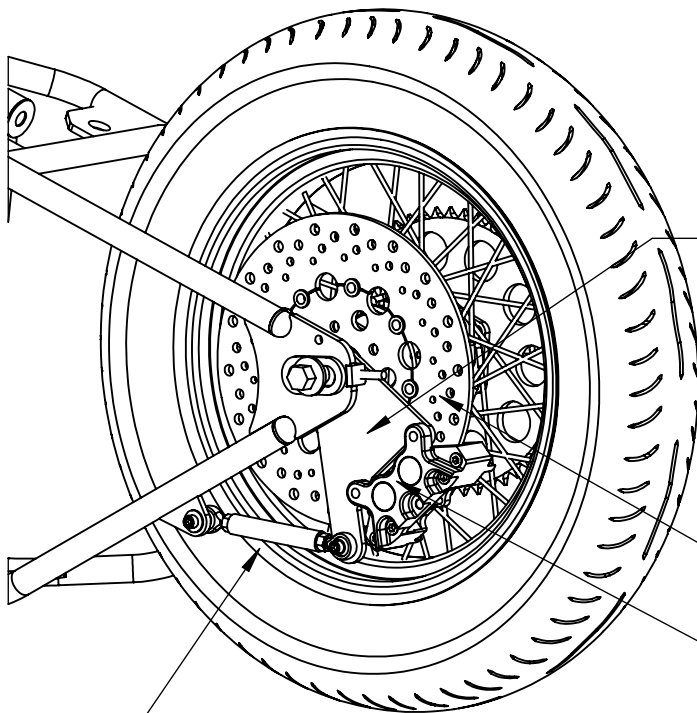
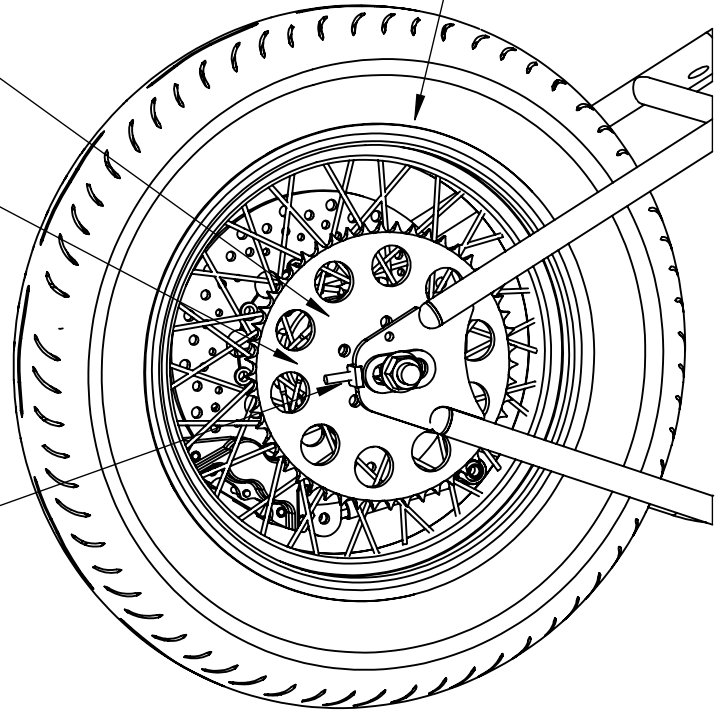

- Lowbrow Customs #010583
Rear Caliper Bracket for 11.5" Rotor Black.
- Lowbrow Customs #010584
Rear Caliper Bracket for 11.5" Rotor Raw.

- 11.5" Rear brake rotor
Lowbrow Customs #012137
Floating Drilled Brake Rotor.

Rear Brake Caliper
with 3.5" hole centers.

- Lowbrow Customs #010630
Brake Caliper Anchor Rod.

ALL PARTS AVAILABLE AT: www.lowbrowcustoms.com

Oil Tank Mounts

- The frame has top mounting tabs for Gasbox #010404 Hoseshoe Oil Tank.
- Install the tank with top rubber grommets, spacer collars, washers and bolts.
- Install the lower mount tab to oil tank with rubber grommets, spacer collars, washers and bolts to locate the tab for tack welding.
- Place small tack welds to secure the bottom mount tab.
- Remove the tank and grommets to finish weld the bottom mount tab.

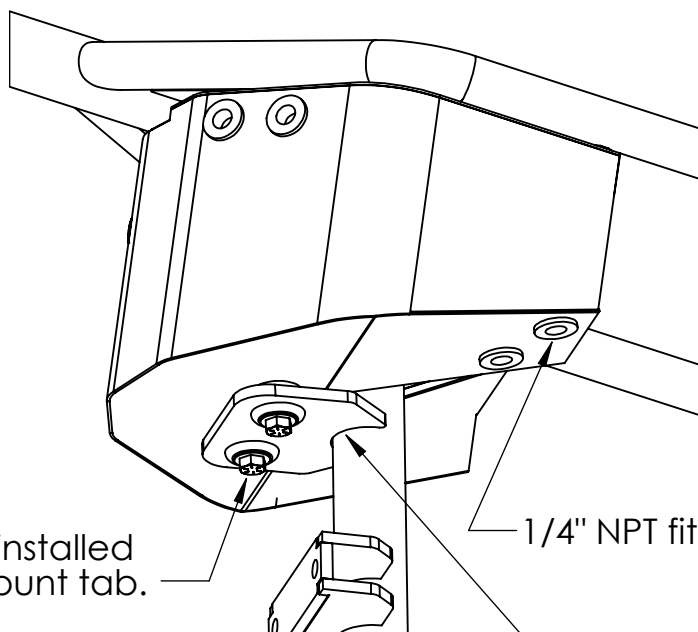
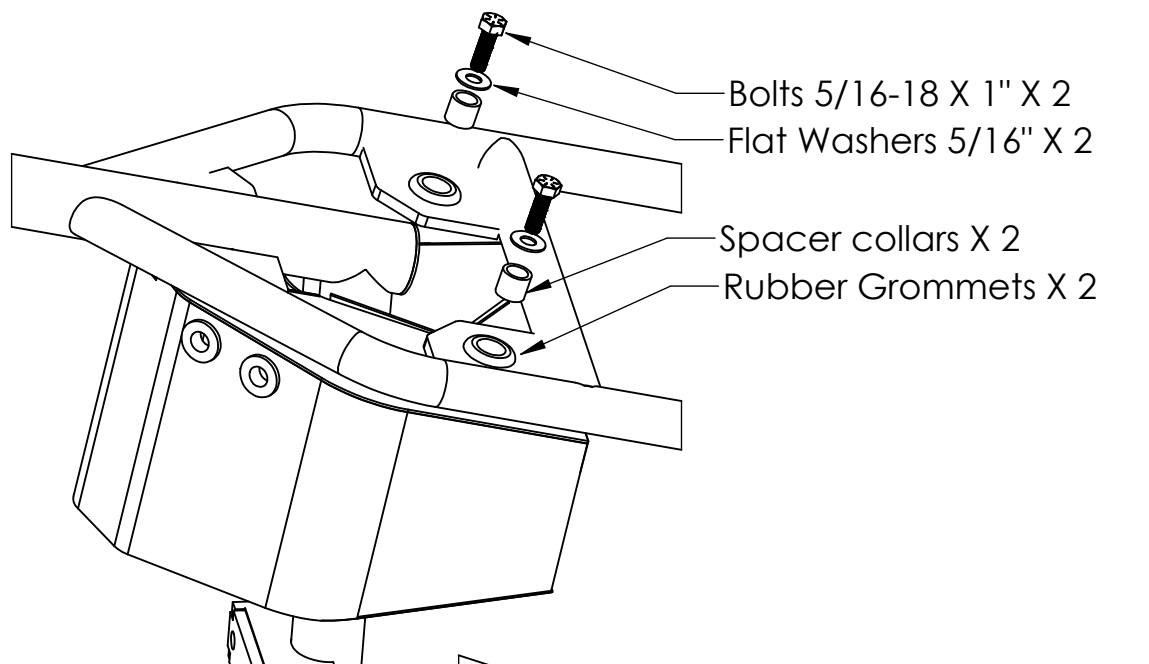

Bolts, Spacer collars, washers and grommets installed to locate the bottom mount tab.

Place small tack welds to locate the bottom mount tab, Remove the tank and grommets to finish weld the tab.

Clamp On Oil Tank

- Gasbox #012459 Dished Clamp On Steel Oil Tank.
- No welding required to mount tank.

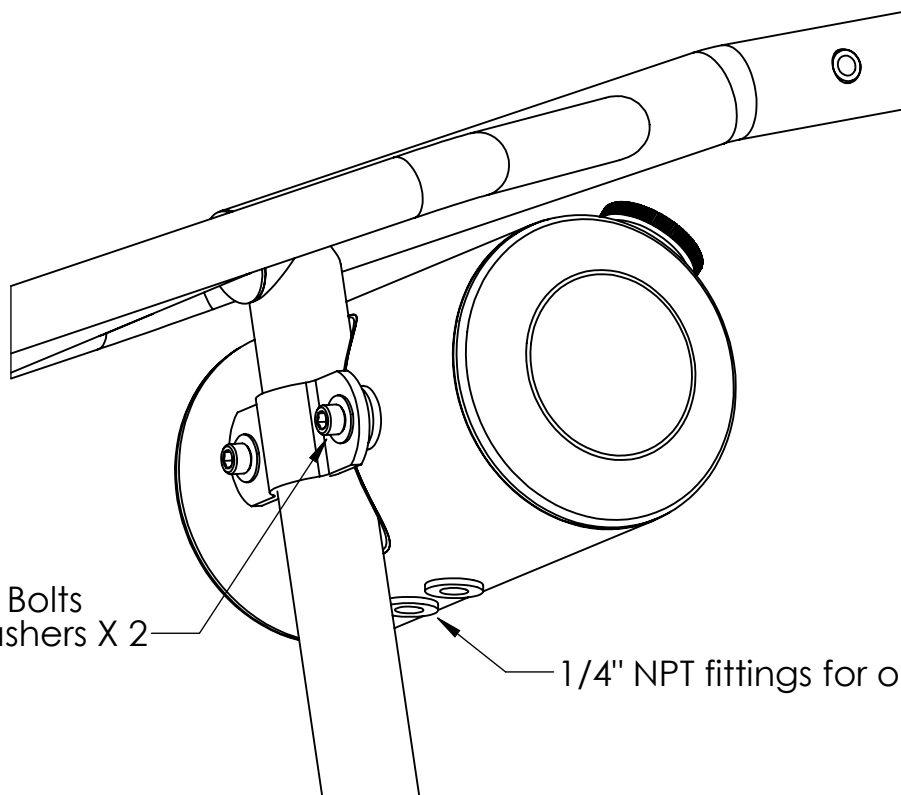
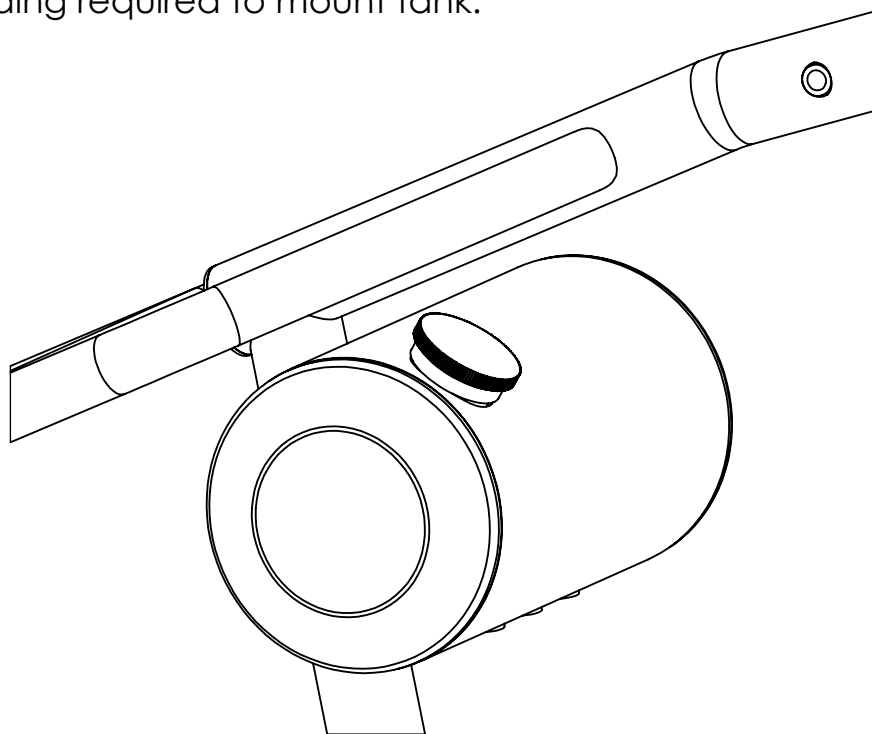

5/16-18 Bolts
and washers X 2

1/4" NPT fittings for oil lines

Battery Mounting



- The frame has holes pre-drilled to install Gasbox #013519 Battery Box Adapter Plate to mount the battery in front of the rear fender.
- The adapter plate can fit:
 - Gasbox #009408 Universal Battery Box for YTZ-12S electric start battery.
 - Gasbox #004489 Antigravity 12 Cell Universal Battery Box.
 - Gasbox #009409 Universal Battery Box for RTX5L-BS Kick Start Battery.
- The adapter plate has an adjustable tab for rear fender mounting.

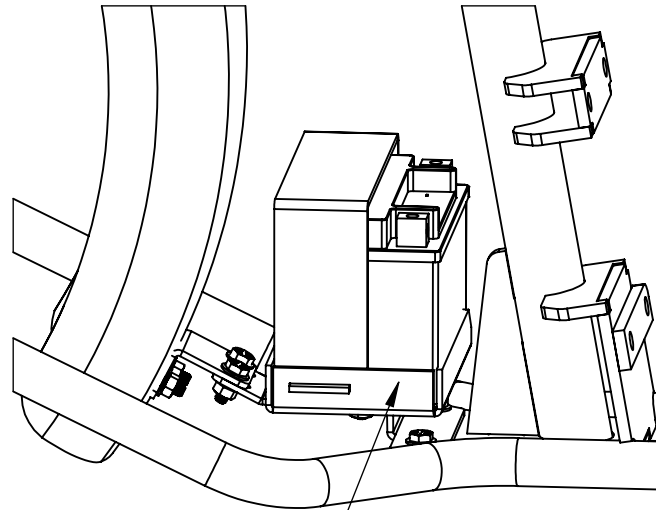

- Gasbox #009408 Universal Battery Box for YTZ-12S electric start battery.
- Gasbox #004489 Universal Battery Box for Antigravity 12 Cell kickstart battery.
- Gasbox #009409 Universal Battery Box for RTX5L-BS kick start battery.

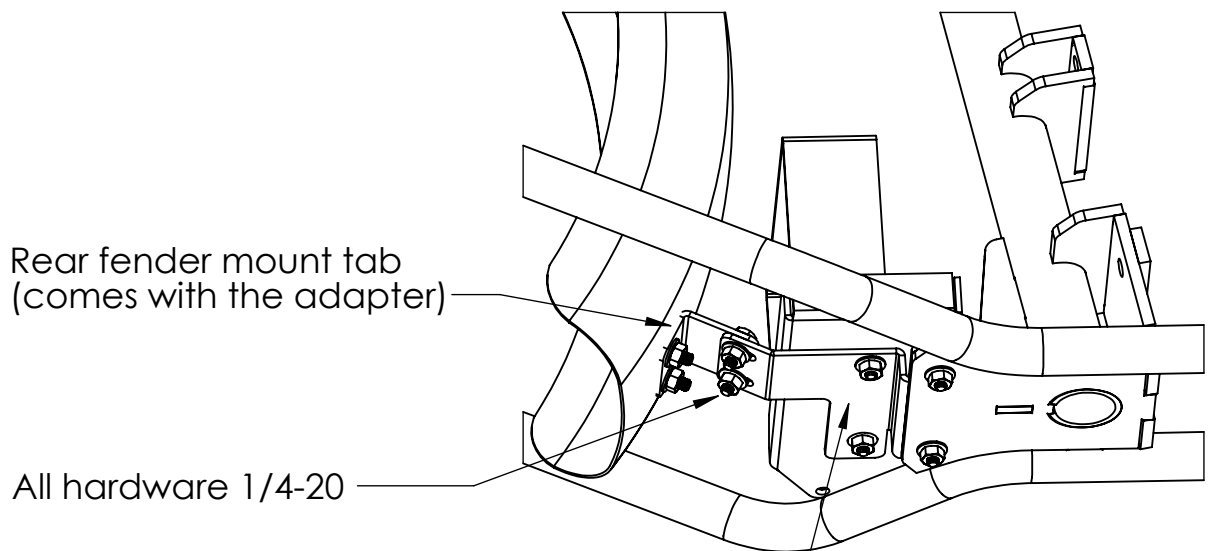

- Gasbox #013519 Battery Box Adapter Plate.

Fender Mounting



- There are many options for rear fender mounting, three versions are shown:
- Use lock nuts or thread lock on all fender components.

- Gasbox #011914 Chrome Shorty Grab Bar- Flat Fenders.
- Lowbrow Customs #002715 Box Chopper Tail Light
- Gasbox #011897 Box Tail Light Universal Fender Mount Bracket

- Lowbrow Customs #008624 Weld-On Upper Fender Mount Tab For Flat Fenders.

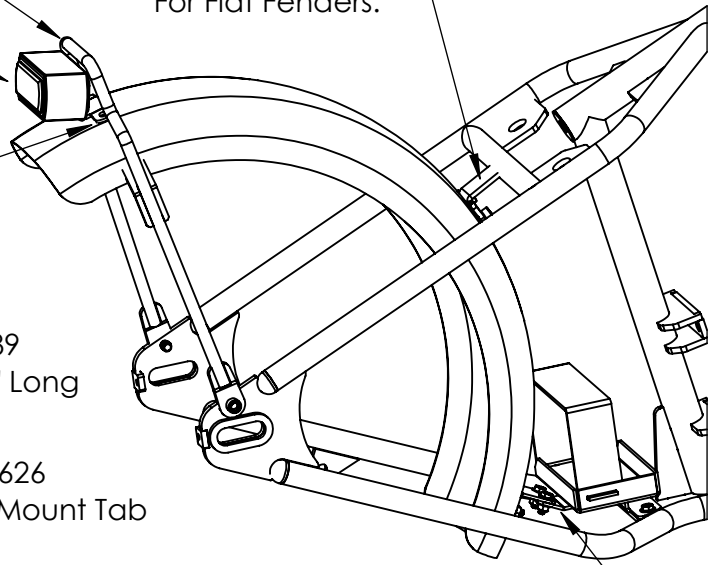

- Lowbrow Customs #000089 Threaded Steel Bung 1/2" Long 5/16-18 Threads.
- Lowbrow Customs #008626 Weld-On Upper Fender Mount Tab For Curved Fenders.

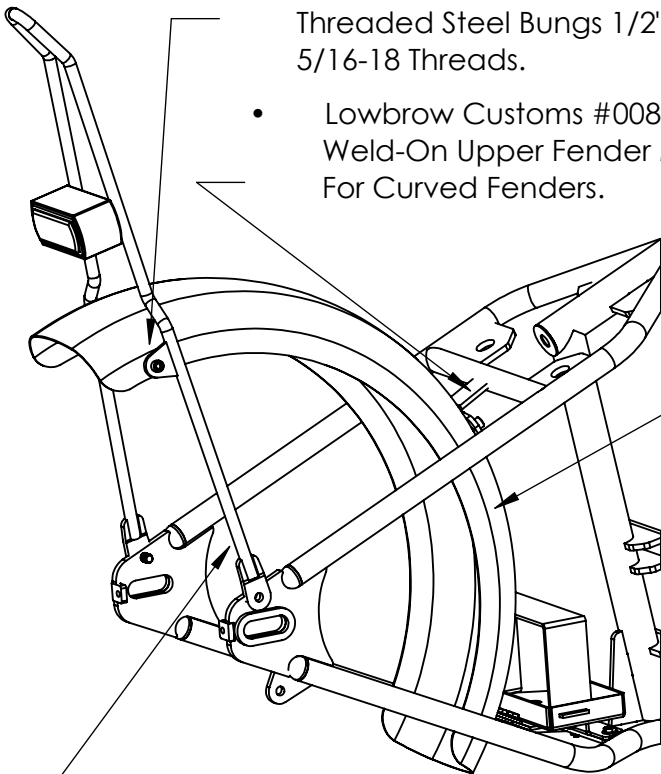

- Gasbox #013519 Battery Box Adapter Plate with Fender Tab.
- Gasbox #001156 Steel 16" Round Fender For Vintage Style Tires.

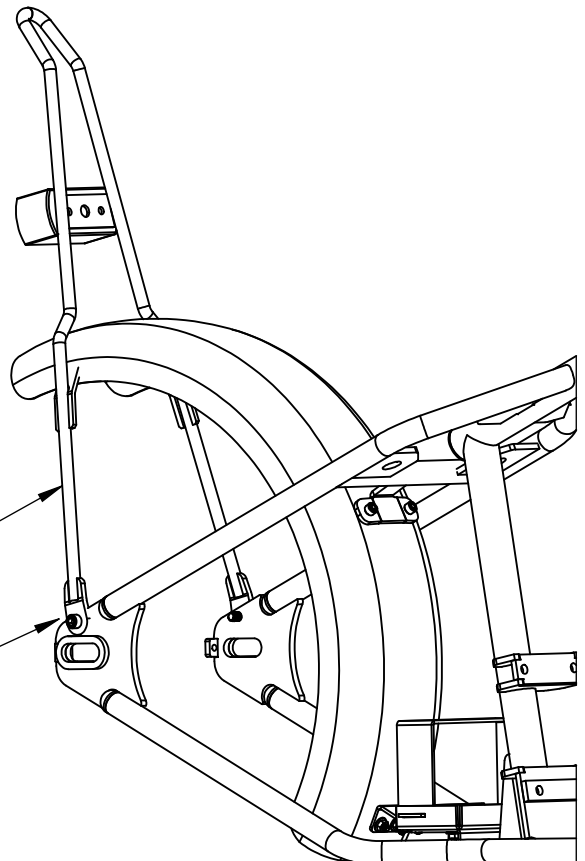

- Gasbox #011913 Chrome Kick Back Sissy Bar- Round Fenders.
- Gasbox #011912 Chrome Kick Back Sissy Bar- Flat Fenders.

Lower Sissy Bar bolts 3/8"

Seat Mounting



- Lowbrow Customs #009495 Black Steel Solo Seat Hinge/Pivot Bracket Weld-On.
- Lowbrow Customs #001475 Solo Seat Springs- Barrel Style- 3 Inch chrome

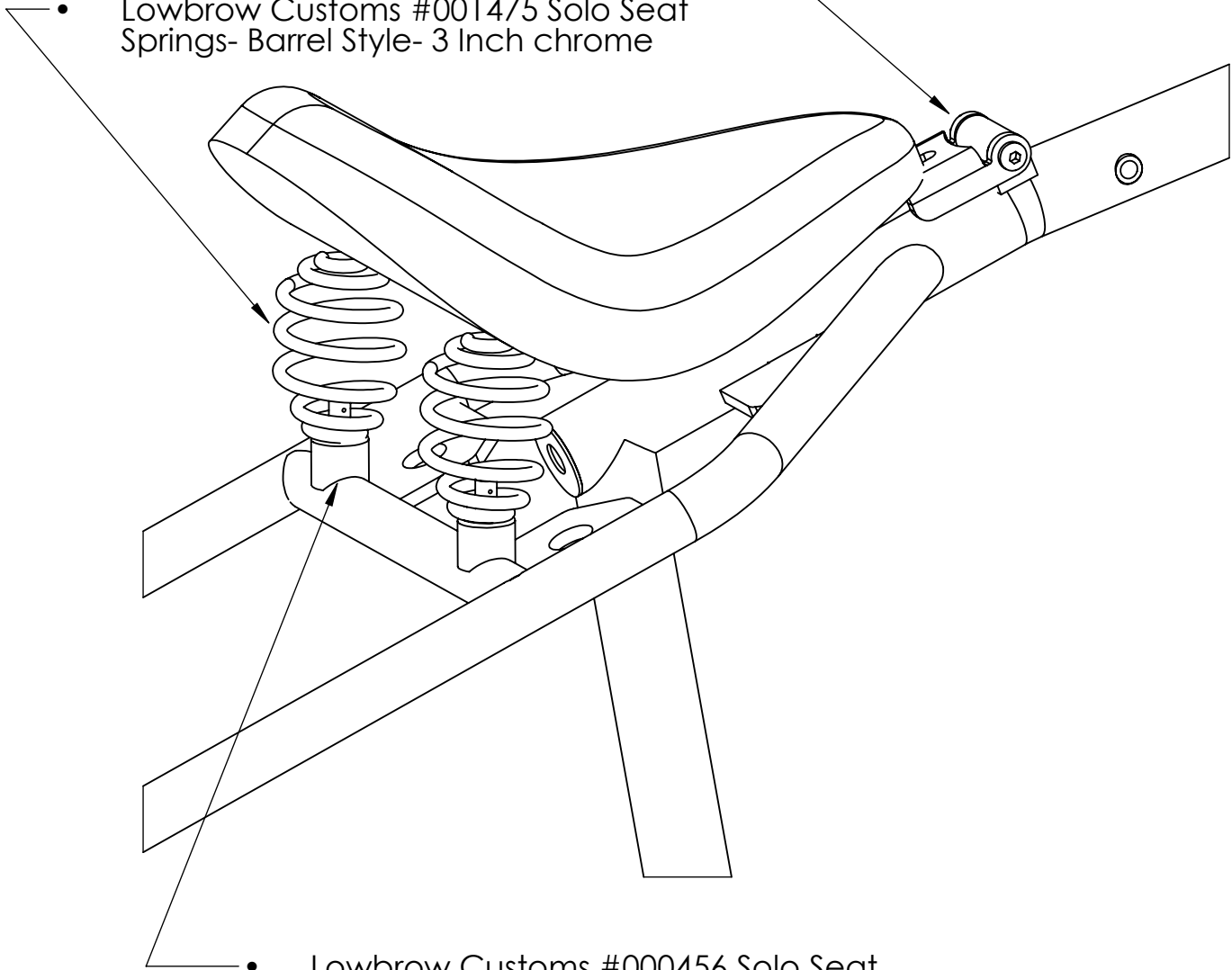

- Lowbrow Customs #000456 Solo Seat Weld-On Spring Mounts/Perches