

NOZZLE SCHEDULE							REMARKS
ITEM	SIZE	RATING	TYPE	MATL.	PROJ IN	PROJ OUT	
A	4"	N.P.T	W.F	C.S	STD.	STD.	PRIMARY EMERGENCY VENT OPENING
B	4"	N.P.T	W.F	C.S	STD.	STD.	SECONDARY EMERGENCY VENT OPENING
C	2"	N.P.T	W.F	C.S	STD.	STD.	

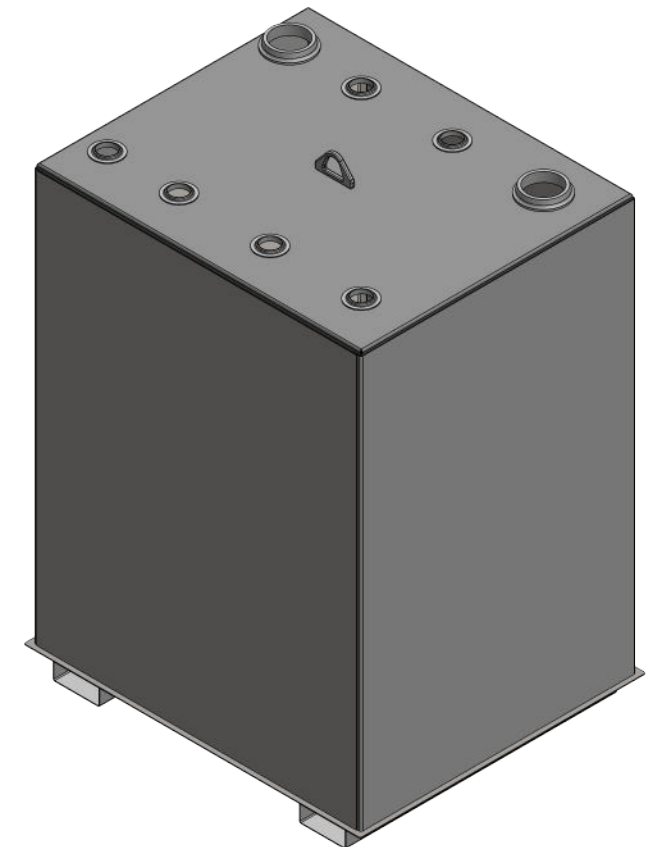
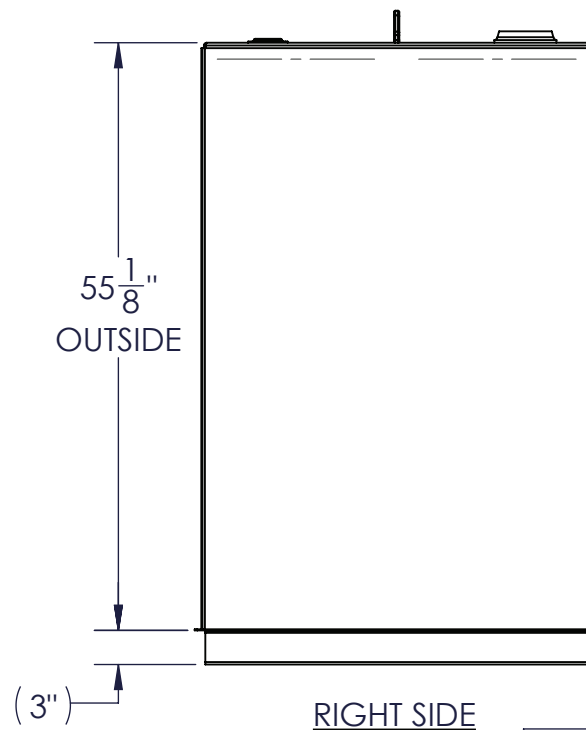
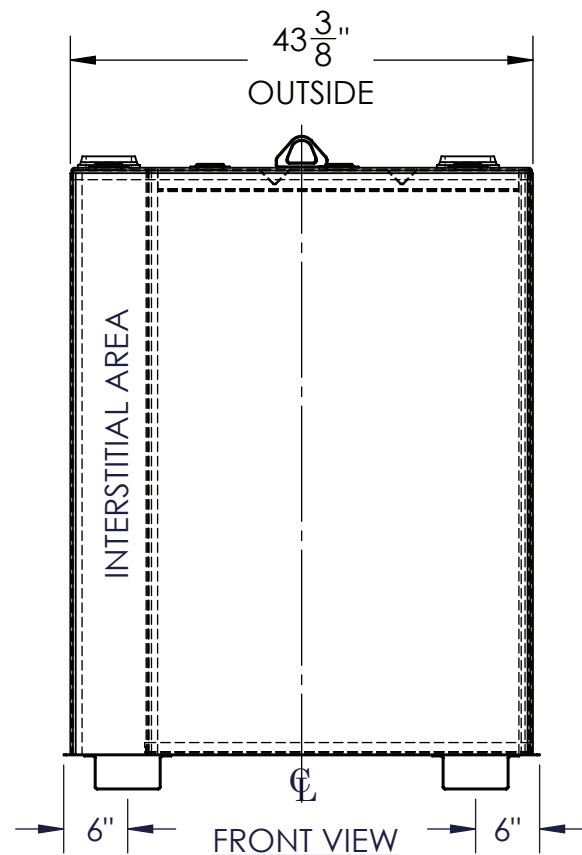
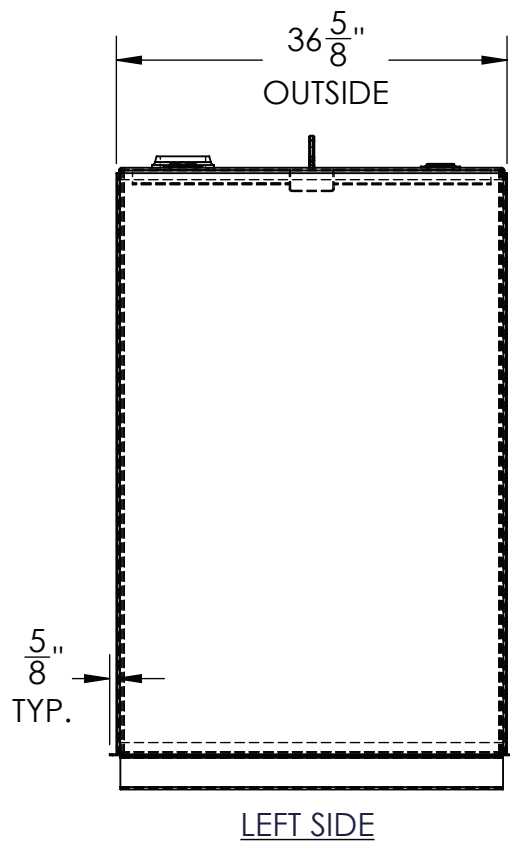

NOTES:

- A. MATERIAL: H.R. CARBON STEEL
- B. DESIGN & OPERATING PRESSURE: ATMOSPHERIC.
- C. DESIGN & OPERATING TEMPERATURE: AMBIENT.
- D. TANK TO BE BUILT & LABELED PER U.L. SPEC. #142.
- E. TANK TO BEAR MANUFACTURERS & U.L. LABELS ONLY.
- F. TANK TO BE AIR TESTED WITH WATER & SOAP SUDS SOLUTION.
- G. INTERIOR: REMOVE WELD SLAG (SHIP CLEAN & DRY).
- H. EXTERIOR: GRAY PRIMER INCLUDED; SEE SALES ORDER FOR TOP COAT.
- I. ALL FITTINGS TO BE PROTECTED FOR SHIPMENT.
- J. CUSTOMER HAS THE RESPONSIBILITY TO VERIFY ALL DIMENSIONS.

APPROVAL FOR CONSTRUCTION
SCHEDULE A - MASTER TERMS &
CONDITION OF SALE*

APPROVED AS DRAWN.

APPROVED WITH NOTED CHANGES,
CONSTRUCTION WILL BE SCHEDULED
WHEN SIGNED DRAWING AND
CONFIRMED ORDER ARE RECEIVED.

SIGNATURE: _____

DATE: _____

*All pages of this Schedule A are incorporated by
reference and are a part of the additional terms of
the Master Terms & Conditions of Sale.
www.newberrytanks.com/masterterms.pdf

SALES ORDER: - WEIGHT (LBS): 702

New Thinking

DESCRIPTION:
300 GALLON RECTANGULAR UL 142 DOUBLE WALL TANK

CUSTOMER: _____ P.O.# _____

DATE: 3/7/2023 SCALE: _____ DWG.# FTDBSW-0300 DRAWN BY: AJC
CHKD BY: _____