

Step 4: Full Motion Adjustment & Maintenance

1. To change the tilt angle of your display, have one person hold the display firmly in place while another person loosens the tilt adjustment nut. Once loosened, move your display to the desired position, and then re-tighten the nut (see Figure.8). Do not release the display until the nut is fully tightened.
2. Swivel adjustments can be made by moving the display to the desired position. Be careful that fingers or cables do not get pinched when moving the mount.

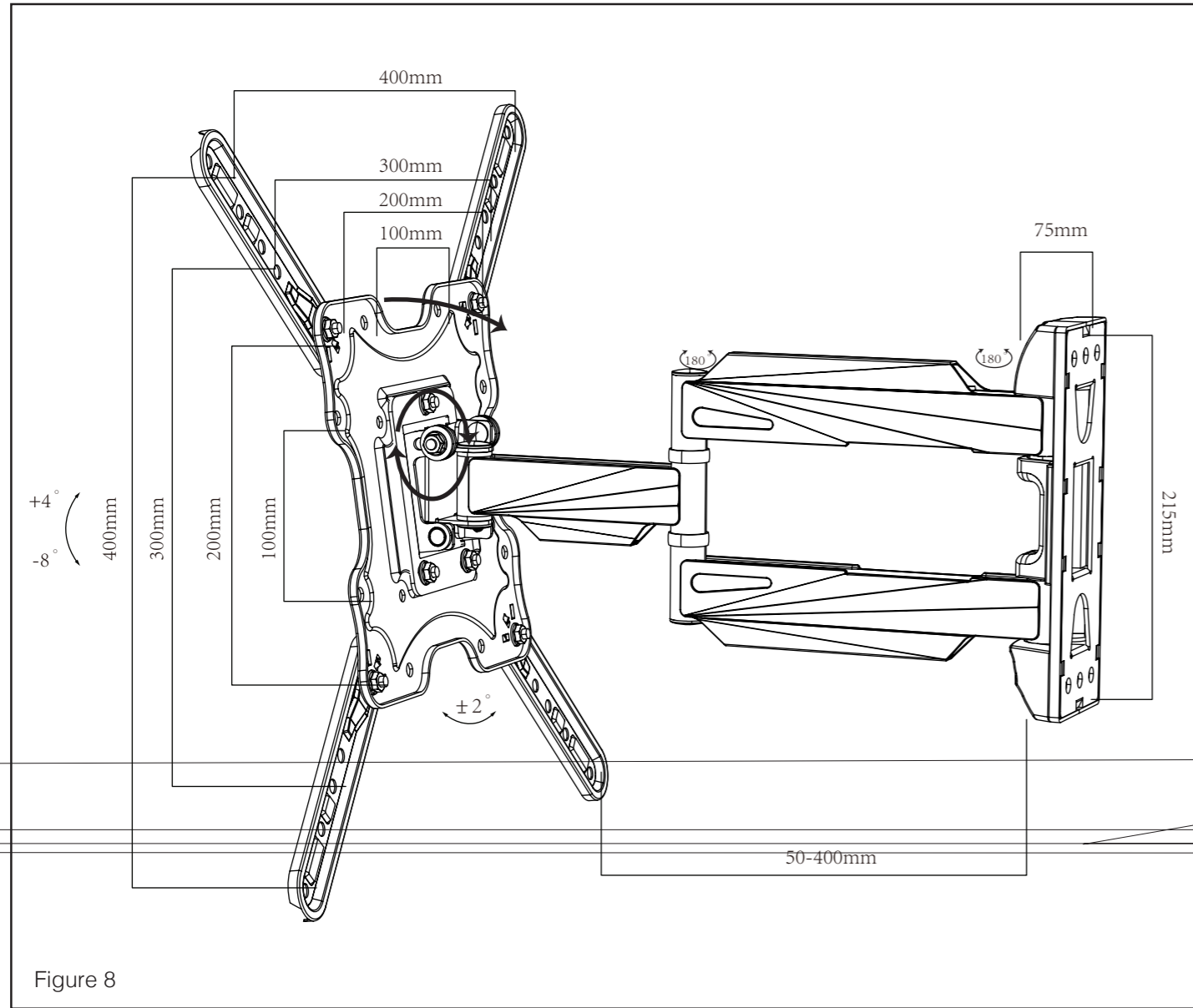

Figure 8

WARNING: Do not loosen too much as the Wall Mount may fall apart.

Check your TV Wall Mount is secure and safe to use at regular intervals (at least every three months).

5 YEAR WARRANTY

Olbertz Holdings Pty Ltd ACN 010 003 933 trading as The Crest Company of 165 South Pine Road, Brendale, Queensland, 4500, Ph: 1800 812 261, www.crest.com.au, warrants that if this Crest product purchased by you from The Crest Company or a retail outlet is found by The Crest Company to be defective in workmanship or materials within 5 years of the date of purchase, The Crest Company will (at its election) either repair that product, replace the product, supply an equivalent product or pay the costs of repairing or replacing the product or acquiring an equivalent product.

This limited warranty will not extend to or cover any expenses associated with removing, demounting the original product or installing the repaired, replaced or equivalent product or all or any of its components, you must bear these expenses. It also does not cover damage or loss resulting from intentional or unintentional misuse of, tampering with, alterations to or incorrect installation of this product or use of this product for purposes other than that for which it is designed or in a manner inconsistent with the product's instructions. This limited warranty also does not apply to damage or loss resulting from fair wear and tear or events beyond The Crest Company control including but not limited to natural disasters.

In order to claim under this warranty, you must contact The Crest Company and return to The Crest Company (via our nominated reply paid address) the product and its components and proof of purchase (including the date and location of purchase) so that The Crest Company can verify the defect and your purchase.

Our goods come with guarantees that cannot be excluded under the Australian Consumer Law. You are entitled to a replacement or refund for a major failure and compensation for any other reasonably foreseeable loss or damage. You are also entitled to have the goods repaired or replaced if the goods fail to be of acceptable quality and the failure does not amount to a major failure. The benefits given by this warranty are in addition to other rights and remedies which you may have under a law in relation to the goods or services to which the warranty relates.

Proudly brought to you by:



PO Box 5658 Brendale
QLD Australia 4500

Customer Support
1800 812 261
www.crest.com.au

AUSTRALIAN OWNED

MFP44FM TV Wall Mount



Full Motion

This TV Wall Mount allows you to move your TV at all angles and extends out up to 40cm from your wall



Compatible TV Size

This TV Wall Mount fits 20-55" (50-140cm) TV Screens



Maximum Mounting Pattern

This TV Wall Mount has a mounting hole pattern up to 400x400mm (WxH)



Maximum TV Weight

This TV Wall Mount supports TVs weighing up to 40kg

SAFETY FIRST

1. Installation of this TV Wall Mount will be easier with two people.
2. Some images in this guide may vary slightly from the actual components supplied.
3. Ensure this instruction manual is completely read and understood before attempting installation.
4. This TV Wall Mount MUST NOT be installed solely in plasterboard, fibre cement and similar surfaces.
5. This TV Wall Mount MUST be installed in sound supporting structures such as those made of timber, steel or masonry using appropriate fasteners.
6. The supporting structure must be capable of sustaining the combined weight of the TV Wall Mount and the display otherwise the structure must be reinforced.
7. The fasteners supplied in this hardware pack allow for fixing into timber and masonry only. If installing into a supporting structure made of steel, appropriate fasteners must be used and sourced from an appropriate supplier.
8. Use appropriate tools and safety equipment and ensure adequate ventilation during installation.
9. If uncertain about any aspect of installation, contact The Crest Company or an installation professional.
10. Please retain these instructions for future reference.

Hardware Kit Contents

ITEM	DESCRIPTION	QTY	ITEM	DESCRIPTION	QTY
A	M6 x 50mm Screw	4	J	M8 Washer	4
B	10 x 50mm Anchor	4	K	Spacer	8
C	M6 x 12mm Bolt	4	L	Wrench	1
D	M6 Locknut	4	M	Wall Plate	1
E	M4 x 25mm Bolt	4	N	Display Plate	1
F	M6 x 25mm Bolt	4	O	Display Plate Adaptors	4
G	M8 x 30mm Bolt	4			
H	M8 x 45mm Bolt	4			
I	M6 Washer	8			

crest

Tools Required

DRYWALL INSTALLATION (TIMBER SUPPORTS):

- Adjustable spanner/socket set
- Philips head screwdriver
- Power drill
- High speed 5mm drill bit
- Spirit level and pencil
- Stud Finder

MASONRY INSTALLATION:

- Adjustable spanner/socket set
- Philips head screwdriver
- Power drill with hammer function
- 10mm Masonry drill bit
- Spirit level and pencil
- Hammer

Step 2: Attach Display Plate

1. Using a second person for assistance, lay your TV face down on something soft so as not to scratch the TV screen.
2. Check the back of your TV to find the appropriate mounting pattern. If the mounting pattern is spaced more than 200mm x 200mm apart, you will need to attach the Display Plate Adaptors (O) to the Display Plate (N). Use the M6 x 12mm (C) bolts, M6 lock nuts (D) and wrench (L) for this (see Figure 3b).
3. Sort through the provided bolts (E to H) until you find the correct size that easily fits into the back of your TV and fits snugly (the bolt must turn at least 3 full turns. If you feel resistance stop immediately and select a smaller bolt).

The Crest Company is not responsible for any damage caused by screwing the bolt too far into the back of the TV.

Once you have selected the correct bolts (E to H), find the corresponding washers (I to J). If no bolts fit you will need to go to your local hardware supplier to find the correct bolt and washer sizes.

4. Gently put the Display Plate on the back of the TV and align to the correct holes.
5. Using the correct bolt size and length, insert these through corresponding washers to attach the Display Plate to the rear of the TV (see Figure 6). If one of the larger bolts is selected or your TV has a curved back, then use the hole spacer (K) to fill out the Display Plate hole and reduce its size for a snugger fit. To avoid damaging TV, do not over tighten bolts.

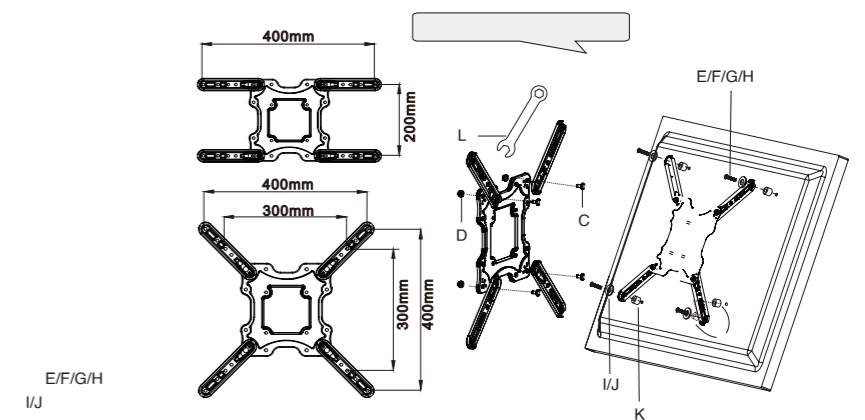

Step 3: Final Assembly

1. With the help of another person, place the Display Plate with your TV attached into the Wall Plate.
Remove the 3 nuts from the back of the Display Plate (N) and then carefully lift and hook into the front part of the wall mount. **Do not release the display until the mount is securely connected.**
Replace the nuts and washers removed above and tighten.
IMPORTANT! The nuts must remain sufficiently tightened at all times to prevent the display from being accidentally knocked from the mount.
2. Attached the Plastic Covers by pressing them onto the wall plate (see Figure 3a).
3. Cables can then be routed through the built in cable covers located on the Wall Plate (see figure 3b).

