

90cm dual fuel freestanding oven with 5 burner gas cooktop, multi-function 8 oven with Twin Fan, and 125L gross capacity.



Product Details

FEATURES

Fast Heat Up

Twin Fan System

Telescopic runners

Cooler touch door
For added safety and confidence in the kitchen, our cooler touch door is beautifully designed with a large window, so you can keep a close eye on your cooking.

Programmable timer

Large 125L gross oven capacity

High powered 14.4 MJ/h wok burner

Cast iron trivets

Triple glazed oven door glass

Handy storage compartment
Extra storage always comes in handy, so with a clever storage compartment you can easily stow away any extra pots and pans.

Fingerprint resistant stainless steel

Clip-on plinth included

BENEFITS

Fast heat up time

Every moment counts, so while your oven heats up super-fast you can save time and get on with cooking the dishes you and your family love.

Twin fan system for even cooking

Cook each dish to perfection with the Twin Fan System. Fans rotate in opposite directions, distributing heat evenly throughout the oven, so you enjoy great results every time.

Designed for ease and safety

Telescopic runners are another piece of thoughtful design that makes it easy to draw racks out and safely check on your dishes during cooking.

All the room for all your family favourites

If you are serious about creating delicious family feasts and you love entertaining, you'll be right at home with our 90cm oven with a generous 125L gross capacity. That's plenty of room for the biggest Christmas turkey or a weekend roast for all the family. The extra width makes getting things in and out super easy.

Bring out the flavour with high heat

Whip up tasty stir-fries and more with our high-powered wok burner. You'll get the high heat you need with 14.4 MJ/h of power at its highest setting.

Built in Australia

Westinghouse, has been the heart of the home for generations and the kitchen appliance brand we have always known and trusted to build reliable products. This oven is built in a local factory in Adelaide.

Specifications

PRODUCT PROFILE

Domestic warranty details (yrs)	2
---------------------------------	---

Oven fuel	electric
-----------	----------

Materials/Colour	mark resistant stainless steel
------------------	--------------------------------

Controls of Oven	control knob,3 button touch control LED
------------------	---

Cooling fan	Yes
-------------	-----

Plinth colour (kickboard)	stainless steel
---------------------------	-----------------

Anti tilt plate	Yes
-----------------	-----

Front/rear controls	front
---------------------	-------

FLUSH FIT CUT OUT

Flush fit cut out height (mm)	900
-------------------------------	-----

Flush fit cut out width (mm)	900
------------------------------	-----

Flush fit cut out depth (mm)	600
------------------------------	-----

DIMENSIONS

PRODUCT DIMENSION

Total height (mm)	910
-------------------	-----

Total width (mm)	895
------------------	-----

Total depth (mm)	600
------------------	-----

MAIN OVEN

Gross capacity litres	125
-----------------------	-----

Useable capacity litres	116
-------------------------	-----

Oven function	multifunction
---------------	---------------

MAIN OVEN

Number of functions	8
Oven liner	pyrolux high temperature enamel
Timer functions	duration,end,minute minder,oven start,Countdown,24 hour clock
Lights	2
Light wattage	25
Light position	top
Light activation by door	Yes
Layers of glass in door	3
Telescopic runners	one
Shelf support	Easy glide side racks
Number of shelves	2
Number of shelf positions	5
Closed door grilling	Yes

ELECTRICAL CONNECTION

SHIPPING

ELECTRICAL CONNECTION

Connected load KW	3.6
-------------------	-----

Maximum current rating (amps)	15
-------------------------------	----

Type of connection	hardwired
--------------------	-----------

SHIPPING

Shipping Volume (m3)	0.675
----------------------	-------

Shipping Weight (Kg)	82
----------------------	----

Pack Dimensions Height (mm)	900
-----------------------------	-----

Pack Dimension Width (mm)	1000
---------------------------	------

Pack Dimension Depth (mm)	750
---------------------------	-----

STUFFING QUANTITIES

20ft	32
------	----

40ft	64
------	----

40ft HC	90
---------	----

COOKTOP (IF APPLICABLE)

PRODUCT PROFILE

Cook top type	gas
---------------	-----

Materials/Colour	stainless steel
------------------	-----------------

Knob finish	metalised
-------------	-----------

ELEMENTS/BURNERS

Cooking zones	5
---------------	---

LEFT REAR ZONE

Left rear zone	semi-rapid
----------------	------------

FEATURES

CONTROLS

Trivets	cast iron
---------	-----------

Ignition type	electronic
---------------	------------

Position of controls	front
----------------------	-------

GAS SPECIFICATIONS

Maximum gas rating (NG)	49.4
-------------------------	------

Position of connection	rear right
------------------------	------------

Dimensions

90cm freestanding cooker

WFE9515SD,
WFE9516DD,
WFEP9717DD

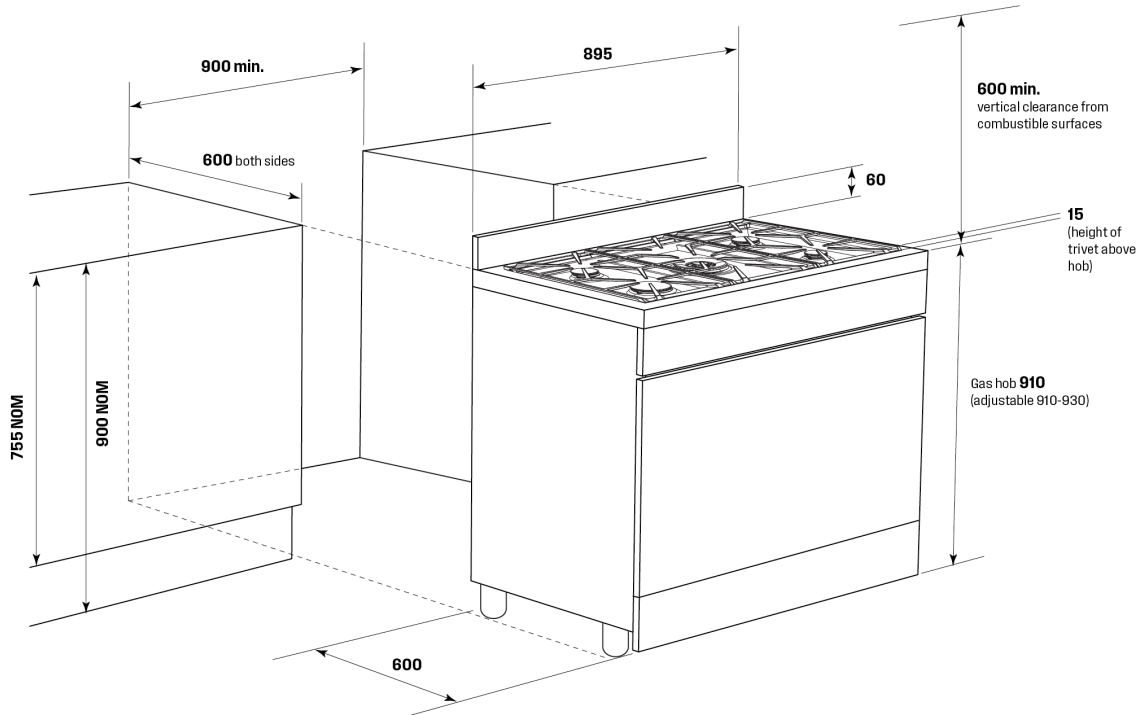

IMPORTANT

These dimensions are a guide only. All measurements are in millimetres (mm).
For complete installation instructions, refer to the manual provided with product.

Terms and Conditions

IMPORTANT

This is a guide of product dimensions only. For complete installation instructions, refer to the manual provided with product.

PRODUCT INFORMATION

The descriptors and illustrations in this publication apply to the specific products and models described as at the date of issue. Under our policy of continuous product development, product specifications may change without notice. Prospective purchasers should therefore check with their retailer to ensure this publication correctly describes the products that are being offered for sale. All information supplied is to be used for general reference purposes only and is on the understanding that Electrolux Home Products Pty Ltd (Australia) and Electrolux (NZ) Ltd (New Zealand) will not be liable for any loss, liability or damage of whatever kind arising as a result of reliance on such information. Colours of products illustrated are as close as printing limitations allow. Electrolux will at all times comply with its obligations pursuant to law including Trade Practices (Australian Consumer Law) Act and Regulations.

WARRANTY

This warranty only applies to Appliances purchased and used in Australia or New Zealand and used in normal domestic applications and is in addition to (and does not exclude, restrict, or modify in any way) any non-excludable statutory warranties in Australia or New Zealand. All warranties are subject to the conditions set out in the warranty card accompanying the product when purchased.

ELECTROLUX HOME PRODUCTS AUSTRALIA

telephone: 1300 363 640

fax: 1800 350 067

email: customercare@electrolux.com.au

web: www.electrolux.com.au

ELECTROLUX HOME PRODUCTS NEW ZEALAND

telephone: 09 573 2230

fax: 09 573 2221

email: customercare@electrolux.co.nz

web: www.electrolux.co.nz