

EAN: 8016361938946

# MODEL WDXOC575AC-AUS



FREESTANDING 7KG WASHING MACHINE & 5KG DRYER

## PRODUCT INFORMATION

### FINISH

- Colour- white (with chrome colour door)

### CAPACITY

- 7kg washing machine capacity
- 5kg dryer capacity
- Drum volume 56L

### CONNECTIVITY

- “One Touch” feature - can be used android phones using the Hoover Wizard app
- NFC technology (near field communication)

### FEATURES

- Electronic programme knob control selector
- Soft touch buttons
- Spin speed - 1500RPM with optional variable speed settings
- Motor- AC
- Stainless steel drum
- Politech Z tub
- Countdown timer
- Moisture monitoring system
- Adjustable feet
- Electronic speed management
- Electronic balance control

### FUNCTIONS

- Anti-crease function
- Programmes number 16 - all baby, all delicate, ALLinONE, hand wash (delicates/silk), high dry, low dry, rapid 14' 30'44', spin, sports wear, wash & dry 59', wool
- Functions - start delay, start/pause, spin speed, key lock, temperature selection, drying selection/steam function, rapid/stain/soil level

### SAFETY

- Door security
- Water protection system- foam control, anti overflow

### TECHNICAL

- Gross weight 73kg, net weight 69kg
- Current A 10
- Fuse rating (A) 10
- Dryer energy rating- 3.5 star

### DISCLAIMER

Eurolinx PTY LTD, is continually seeking ways to improve the design specifications, aesthetics and production techniques of its products. As a result alterations to our products and designs take place continually. Whilst every effort is made to produce information and literature that is up to date, this brochure should not be regarded as an infallible guide to the current specifications, nor does it constitute an offer for the sale of any particular product. Product dimensions indicated in our literature is indicative only. Actual product only should be used to define dimension cut outs. Distributors, and retailers are not agents of Eurolinx and are not authorized to bind Eurolinx by any express or implied undertaking or representation.



DYNAMIC NEXT

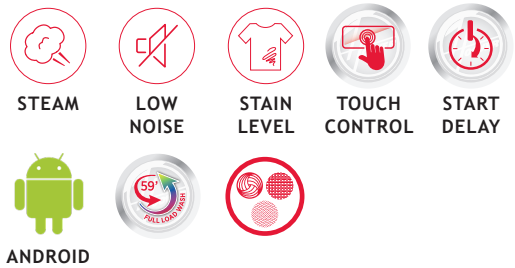

21122020

FOLLOW US ON: [hoover\\_appliancesAU](https://www.instagram.com/hoover_appliancesAU)

[www.hooverappliances.com.au](http://www.hooverappliances.com.au)

Australian National Telephone Number 1300 694 583  
Office Hours: Monday - Friday 8:30am-5pm  
Showroom Hours: Tuesday - Friday 9am-5pm & Saturday 10am-4pm  
Closed Sunday & Monday

**NSW & ACT (Head Office)**  
48-50 Moore Street  
Leichhardt  
F 02 8569 4699

**QLD**  
1/42 Cavendish Road  
Coorparoo  
F 07 3397 0850

**WA & NT**  
Unit 10/55 Howe Street  
Osborne Park  
F 08 9201 9188

EAN: 8016361938946

# MODEL WDXOC575AC-AUS



FREESTANDING 7KG WASHING MACHINE & 5KG DRYER

## TECHNICAL DIAGRAM

WDXOC 575AC-AUS

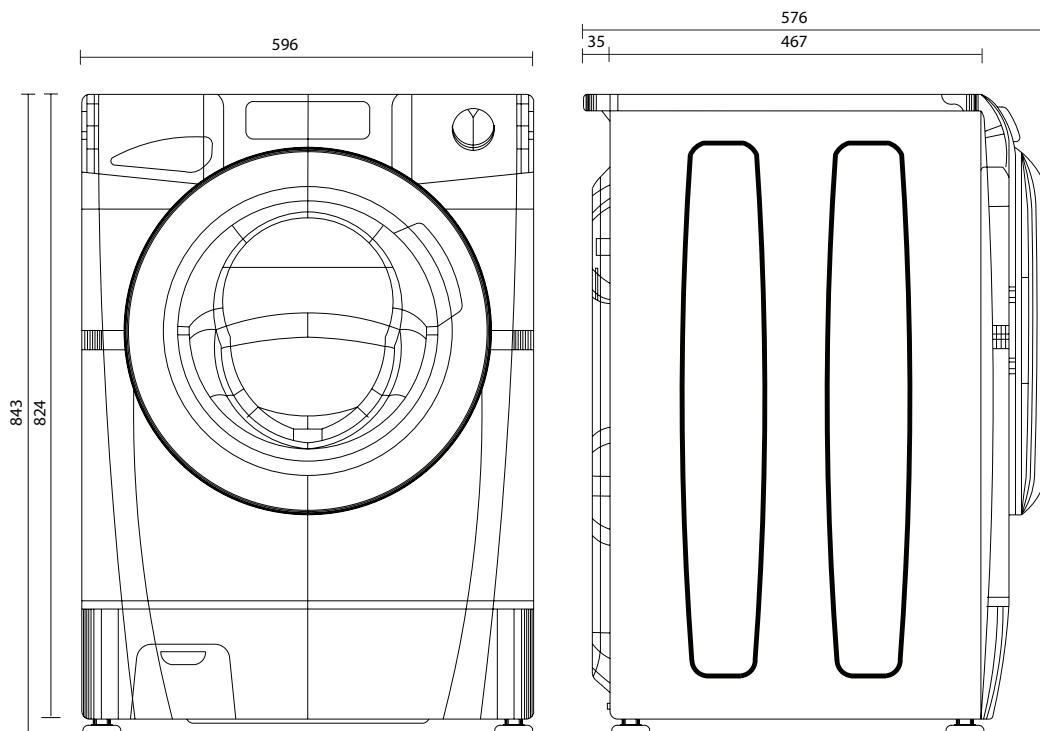

Model WDXOC575AC 7kg washing machine & 5kg dryer  
 Max absorbed power (W) 2150  
 Voltage V 220-240  
 Length inlet hose 150cm, length drain hose 200cm, length electrical supply cord 160cm

### DISCLAIMER

Eurolinx PTY LTD, is continually seeking ways to improve the design specifications, aesthetics and production techniques of its products. As a result alterations to our products and designs take place continually. Whilst every effort is made to produce information and literature that is up to date, this brochure should not be regarded as an infallible guide to the current specifications, nor does it constitute an offer for the sale of any particular product. Product dimensions indicated in our literature is indicative only. Actual product only should be used to define dimension cut outs. Distributors, and retailers are not agents of Eurolinx and are not authorized to bind Eurolinx by any express or implied undertaking or representation.

21122020

**FOLLOW US ON:** [hover\\_appliancesAU](https://www.instagram.com/hover_appliancesAU)

[www.hooverappliances.com.au](http://www.hooverappliances.com.au)

Australian National Telephone Number 1300 694 583  
 Office Hours: Monday - Friday 8:30am-5pm  
 Showroom Hours: Tuesday - Friday 9am-5pm & Saturday 10am-4pm  
 Closed Sunday & Monday

**NSW & ACT (Head Office)**  
 48-50 Moore Street  
 Leichhardt  
 F 02 8569 4699

**QLD**  
 1/42 Cavendish Road  
 Coorparoo  
 F 07 3397 0850

**WA & NT**  
 Unit 10/55 Howe Street  
 Osborne Park  
 F 08 9201 9188