

GMWG28TK

Built-In Microwave 600mm

Features

- 8 Auto cooking menus
- 5 power levels
- Digital control
- 28 litre capacity
- 900W microwave power
- 1100W grill power
- Speed cooking function
- 30 second quick start
- Child safety coat

- Stainless steel front panel & trim kit
- Silver housing cabinet
- 19 kg

Standard Accessories

- Glass turntable – 315mm
- Chrome grill rack

Power

- Total: 1450W (6.04amp)
- Fitted with 10 amp plug + lead

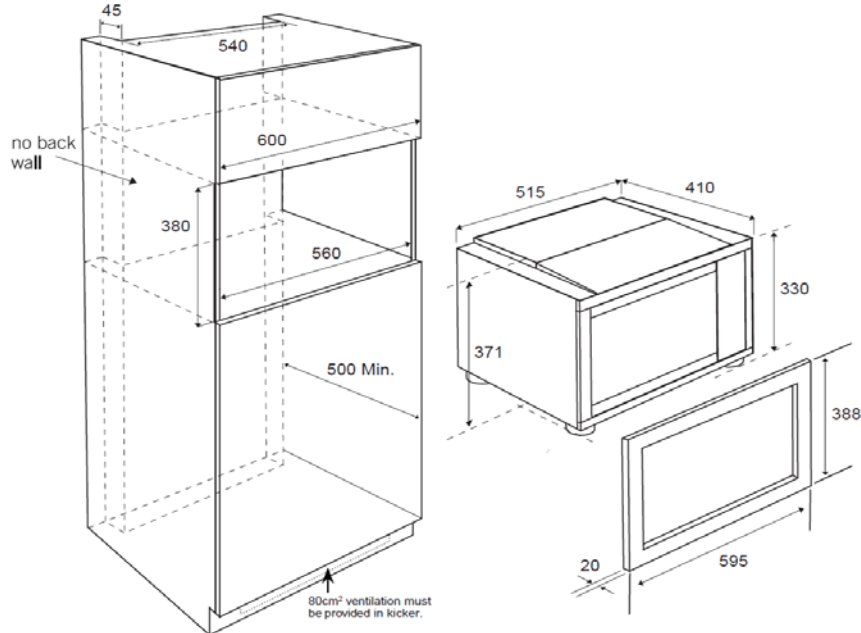

Product Dimensions

595mm (W) x 388mm (H) x 410mm (D) including trim kit

2 Year Warranty

Under Bench Installation

IMPORTANT: Cabinet housing Microwave Oven must have improved air flow to avoid overheating of the appliance – See minimum requirements below