

# 70CM INTEGRATED REFRIGERATOR & FREEZER

MODEL AINT7000

 **ARTUSI**  
THE ART OF LIVING



36 MONTH  
WARRANTY



70CM



LED  
LIGHTS



SHELF  
POSITIONS



255L FRIDGE  
CAPACITY



86L FREEZER  
CAPACITY



34L FRESH FOOD  
COMPARTMENT



## PRODUCT INFORMATION

### FEATURES

- electronic touch control display
- super cool function
- super freezing function
- ECO function
- holiday function
- door open alarm
- reversible door
- frost free
- safety glass shelves
- full height LED panel illuminates the entire fridge

### CAPACITY

- refrigerator: 255L net
- fresh zone compartment: 34L net
- freezer: 86L net
- Total gross: 350L
- Total net: 341L

### TEMPERATURE RANGE

- Fridge: 5°C - 2°C
- Fresh Zone: 3°C - -3°C
- Freezer: -15°C - -25°C

### COMPARTMENTS

- 3 freezer drawer compartments
- 4 fridge adjustable shelves
- 1 x vegetable crisper drawer
- 1 x meat storage drawer
- 1 x large door shelf
- 3 x medium door shelves

### ACCESSORIES

- 1 x egg tray
- 1 x ice tray

### TECHNICAL INFORMATION

- 4-Star energy rating (freezer compartment)
- 3 Star energy rating (refrigerator)
- 2m power cord
- 690W x 1937H x 550D
- max. door weight: 15kgs per door

### DISCLAIMER

Eurolinx PTY LTD, is continually seeking ways to improve the design specifications, aesthetics and production techniques of its products. As a result alterations to our products and designs take place continually. Whilst every effort is made to produce information and literature that is up to date, this brochure should not be regarded as an infallible guide to the current specifications, nor does it constitute an offer for the sale of any particular product. Product dimensions indicated in our literature is indicative only. Actual product only should be used to define dimension cut outs. Distributors, and retailers are not agents of Eurolinx and are not authorized to bind Eurolinx by any express or implied undertaking or representation.

EAN 9347777005021

AR09052022



### FOLLOW US ON:

 [instagram.com/artusi\\_appliances](https://www.instagram.com/artusi_appliances)

 [www.linkedin.com/company/eurolinx-pty-ltd-t-a-llve/](https://www.linkedin.com/company/eurolinx-pty-ltd-t-a-llve/)

Australia National Telephone Number 1300 (694 583) New Zealand Telephone Number 64 3 344 5913  
Artusi showroom hours: Tuesday to Friday - 9am-5pm, Saturday - 10am-4pm, Sunday and Monday - closed  
\* Melbourne showroom hours: Tuesday to Saturday - 10am-4pm

[artusi.com.au](https://www.artusi.com.au)

**NSW & ACT (Head Office)**  
48-50 Moore Street  
Leichhardt

**VIC & SA**  
2R/131 Church Street  
Hawthorn

**QLD**  
1/42 Cavendish Road  
Coorparoo

**WA & NT**  
Unit 10/55 Howe Street  
Osborne Park

**New Zealand**  
PO Box 11.160  
Sockburn Christchurch

# 70CM INTEGRATED REFRIGERATOR & FREEZER

MODEL AINT7000

 **ARTUSI**  
THE ART OF LIVING

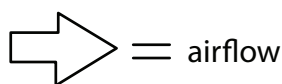
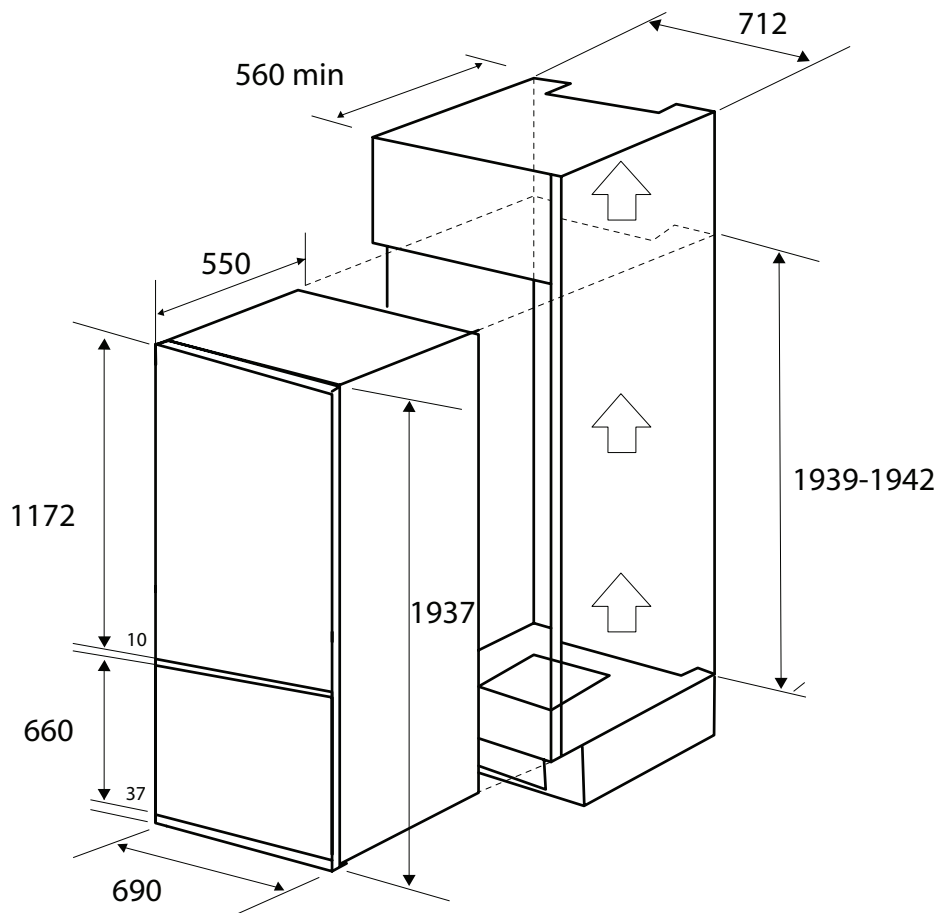

NB: drawings are not to scale — they are to be used for detailed installation instructions, please refer to user guide.

**EAN 9347777005021**

AR09052022

#### DISCLAIMER

Eurolinx PTY LTD, is continually seeking ways to improve the design specifications, aesthetics and production techniques of its products. As a result alterations to our products and designs take place continually. Whilst every effort is made to produce information and literature that is up to date, this brochure should not be regarded as an infallible guide to the current specifications, nor does it constitute an offer for the sale of any particular product. Product dimensions indicated in our literature is indicative only. Actual product only should be used to define dimension cut outs. Distributors, and retailers are not agents of Eurolinx and are not authorized to bind Eurolinx by any express or implied undertaking or representation.

**FOLLOW US ON:**  [instagram.com/artusi\\_appliances](https://www.instagram.com/artusi_appliances)

 [www.linkedin.com/company/eurolinx-pty-ltd-t-a-lve/](https://www.linkedin.com/company/eurolinx-pty-ltd-t-a-lve/)

Australia National Telephone Number 1300 (694 583) New Zealand Telephone Number 64 3 344 5913  
Artusi showroom hours: Tuesday to Friday - 9am-5pm, Saturday - 10am-4pm, Sunday and Monday - closed  
\* Melbourne showroom hours: Tuesday to Saturday - 10am-4pm

[artusi.com.au](https://www.artusi.com.au)

**NSW & ACT (Head Office)**  
48-50 Moore Street  
Leichhardt

**VIC & SA**  
2R/131 Church Street  
Hawthorn

**QLD**  
1/42 Cavendish Road  
Coorparoo

**WA & NT**  
Unit 10/55 Howe Street  
Osborne Park

**New Zealand**  
PO Box 11.160  
Sockburn Christchurch