

# INTEGRATED REFRIGERATOR & FREEZER

MODEL AINT3000

**ARTUSI**  
THE ART OF LIVING



## PRODUCT INFORMATION

### FEATURES

- Supplied with left hand hinge
- Reversible door
- Fixed hinge door system
- Touch control
- LED lighting with adjustable thermostat cooling intensity
- Acoustic door alarm
- Holiday mode
- Fresh zone (chiller box) temperature selection -2°C to 3°C
  - The fresh zone will help meat, fish and dairy products stay fresher for longer and also keep any unwanted odours from the main fridge compartment
- Smart mode (sets the fridge to 5°C and freezer to -18°C)
- Fast Cool & Freeze (sets the fridge to 2°C for 2 hours & freezer to -25°C for 6 hours)
- 300kw/yr energy consumption
- 41 dBA max noise level
- ON/OFF setting

### SHELVES

- 4 x removable glass shelves
- 1 x chrome (foldable) wine or beverage rack
- 1 x vegetable crisper
- 1 x meat compartment
- Chiller compartment with telescopic rails
- 3 x balconies on door (1 large, 2 medium)
- 3-drawer freezer compartment

### DISCLAIMER

Eurolinx PTY LTD, is continually seeking ways to improve the design specifications, aesthetics and production techniques of its products. As a result alterations to our products and designs take place continually. Whilst every effort is made to produce information and literature that is up to date, this brochure should not be regarded as an infallible guide to the current specifications, nor does it constitute an offer for the sale of any particular product. Product dimensions indicated in our literature is indicative only. Actual product only should be used to define dimension cut outs. Distributors, and retailers are not agents of Eurolinx and are not authorized to bind Eurolinx by any express or implied undertaking or representation.

## CAPACITY & TEMPERATURE RANGE

- Refrigerator: 177 litres (net)  
2°C - 8°C
- Freezer: 64 litres (net)  
- 15°C - - 25°C

## ACCESSORIES

- Ice-cube tray, egg tray

## DETAILED INFORMATION

- 10 amp GPO electrical connection, 3-pin plug
- 190cm power cord
- weight: 58kg (net)



EAN TBA

AR02032023

**FOLLOW US ON:**  [/artusi\\_kitchen\\_laundry\\_outdoor](https://www.instagram.com/artusi_kitchen_laundry_outdoor)

Australia National Telephone Number 1300 MYILVE (694 583) New Zealand Telephone Number 0508 458 369  
ILVE showrooms are open daily from 9am-5pm and Saturdays 10am-4pm

[artusi.com.au](https://www.artusi.com.au)

**NSW & ACT (Head Office)**  
48-50 Moore Street  
Leichhardt  
F 02 8569 4699

**Victoria**  
2r/131 Church Street  
Hawthorn

**QLD**  
1/42 Cavendish Road  
Coorparoo

**WA & NT**  
Unit 10/55 Howe Street  
Osborne Park

**New Zealand**  
PO Box 11, 160  
Sockburn Christchurch

# INTEGRATED REFRIGERATOR & FREEZER

MODEL AINT3000

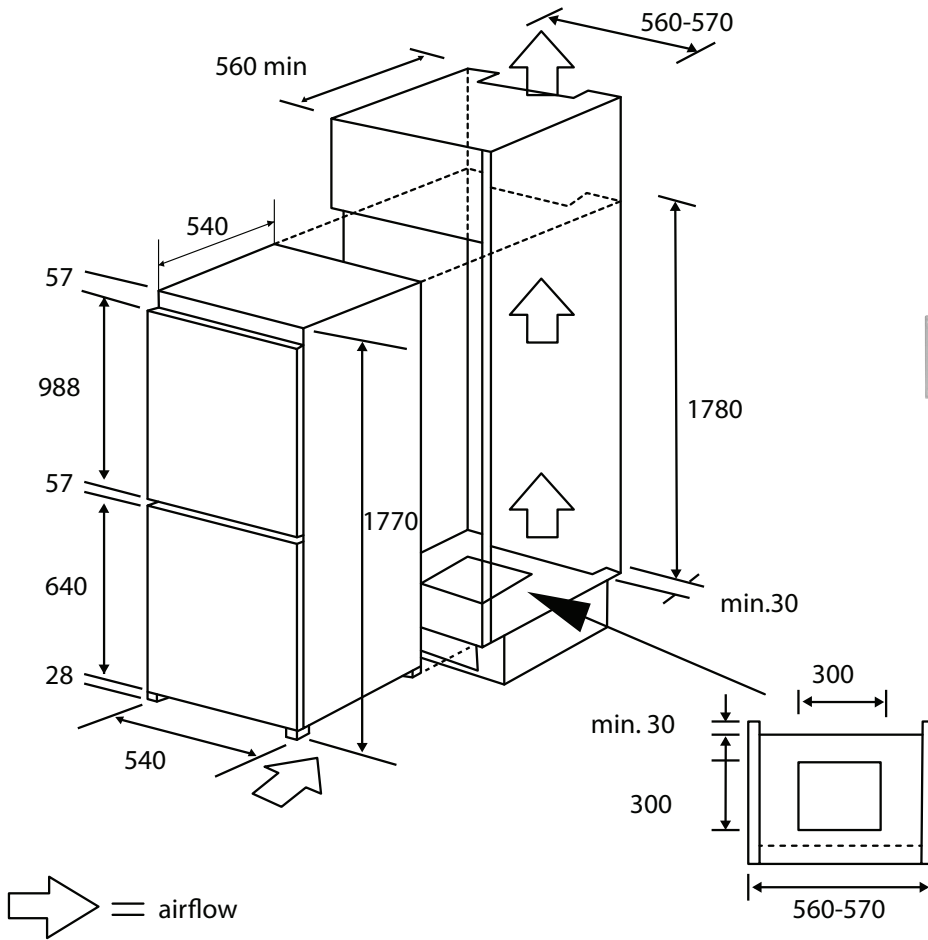

## Installation kit

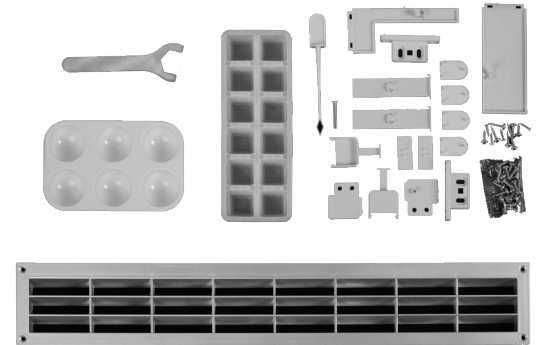

NB: drawings are not to scale — they are to be used for detailed installation instructions, please refer to user guide.

**EAN TBA**

AIN3000  
540W x 550D x 1769H mm  
10 AMP, 190cm power cord

AR02032023

### DISCLAIMER

Eurolinx PTY LTD, is continually seeking ways to improve the design specifications, aesthetics and production techniques of its products. As a result alterations to our products and designs take place continually. Whilst every effort is made to produce information and literature that is up to date, this brochure should not be regarded as an infallible guide to the current specifications, nor does it constitute an offer for the sale of any particular product. Product dimensions indicated in our literature is indicative only. Actual product only should be used to define dimension cut outs. Distributors, and retailers are not agents of Eurolinx and are not authorized to bind Eurolinx by any express or implied undertaking or representation.

**FOLLOW US ON:**  [/artusi\\_kitchen\\_laundry\\_outdoor](https://www.instagram.com/artusi_kitchen_laundry_outdoor)

Australia National Telephone Number 1300 MYILVE (694 583) New Zealand Telephone Number 0508 458 369  
ILVE showrooms are open daily from 9am-5pm and Saturdays 10am-4pm

[artusi.com.au](http://artusi.com.au)

**NSW & ACT (Head Office)**  
48-50 Moore Street  
Leichhardt  
F 02 8569 4699

**Victoria**  
2r/131 Church Street  
Hawthorn

**QLD**  
1/42 Cavendish Road  
Coorparoo

**WA & NT**  
Unit 10/55 Howe Street  
Osborne Park

**New Zealand**  
PO Box 11.160  
Sockburn Christchurch