

MODEL ACM45MB 60CM BUILT-IN COMBINATION MICROWAVE OVEN

EXCLUSIVE TO SELECT PARTNERS
CONSULT WITH YOUR ARTUSI REPRESENTATIVE



MADE
IN ITALY



24 MONTH
WARRANTY



60CM



COOKING
FUNCTIONS



SHELF
POSITIONS



CHILD
LOCK



TOUCH
CONTROL

PRODUCT INFORMATION

FINISH

- Matt Black Enamel

FEATURES

- preset recipes with automatic cooking time and weight preset for a variety of family meals
- full-glass oven door and inner glass
- TFT touch control panel
- Electronic timer and clock

SAFETY

- Safe touch glass door
- Child lock

FUNCTIONS

- 9 combi cooking modes
- 3 microwave cooking wattage levels
- Forced-air cooking
- Combination microwave and forced-air cooking
- Combination microwave cooking and grill

CLEANING

- Stainless steel cavity

CAPACITY & INTERIOR

- Oven cavity size (cm): 42.3w x 37.7d x 21h
- 3 shelf positions

ACCESSORIES

- 1 x round grill, 1 x stainless steel tray with support grill



EAN 9347777003539

AR14042022

DISCLAIMER

Eurolinx PTY LTD, is continually seeking ways to improve the design specifications, aesthetics and production techniques of its products. As a result alterations to our products and designs take place continually. Whilst every effort is made to produce information and literature that is up to date, this brochure should not be regarded as an infallible guide to the current specifications, nor does it constitute an offer for the sale of any particular product. Product dimensions indicated in our literature is indicative only. Actual product only should be used to define dimension cut outs. Distributors, and retailers are not agents of Eurolinx and are not authorized to bind Eurolinx by any express or implied undertaking or representation.

FOLLOW US ON:  [instagram.com/artusi_appliances](https://www.instagram.com/artusi_appliances)

 www.linkedin.com/company/eurolinx-pty-ltd-t-a-lv/

Australia National Telephone Number 1300 (694 583) New Zealand Telephone Number 64 3 344 5913
Artusi showroom hours: Tuesday to Friday - 9am-5pm, Saturday - 10am-4pm, Sunday and Monday - closed
* Melbourne showroom hours: Tuesday to Saturday - 10am-4pm

[artusi.com.au](https://www.artusi.com.au)

NSW & ACT (Head Office)
48-50 Moore Street
Leichhardt
F 02 8569 4699

QLD
1/42 Cavendish Road
Coorparoo
F 07 3397 0850

WA & NT
Unit 10/55 Howe Street
Osborne Park
F 08 9201 9188

New Zealand
PO Box 11,160
Sockburn Christchurch
F 03 344 5906

MODEL ACM45MB 60CM BUILT-IN COMBINATION MICROWAVE OVEN

EXCLUSIVE TO SELECT PARTNERS
CONSULT WITH YOUR ARTUSI REPRESENTATIVE

TECHNICAL DIAGRAM

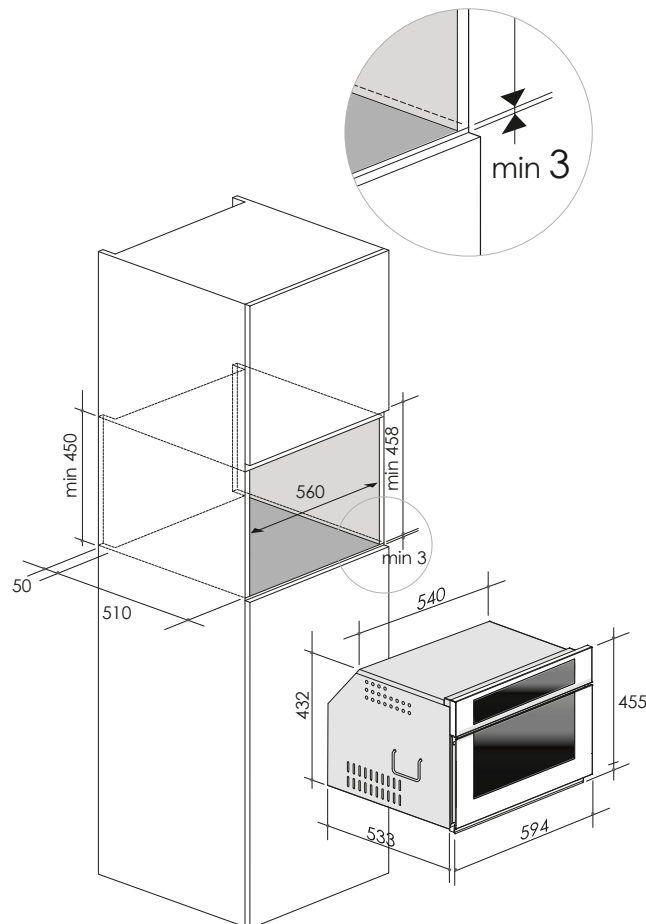

NB: drawings are not to scale — they are to be used for detailed installation instructions, please refer to user guide.

EAN 9347777003539

AR14042022

DISCLAIMER

Eurolinx PTY LTD, is continually seeking ways to improve the design specifications, aesthetics and production techniques of its products. As a result alterations to our products and designs take place continually. Whilst every effort is made to produce information and literature that is up to date, this brochure should not be regarded as an infallible guide to the current specifications, nor does it constitute an offer for the sale of any particular product. Product dimensions indicated in our literature is indicative only. Actual product only should be used to define dimension cut outs. Distributors, and retailers are not agents of Eurolinx and are not authorized to bind Eurolinx by any express or implied undertaking or representation.

ACM45MB Built-in Combination Microwave Oven

Power Consumption: 3.5kW/hr total electrical consumption

Hard wired, supplied with 1.2m cable

Size: 594W x 455H x 533D + 21mm fascia

FOLLOW US ON:  [instagram.com/artusi_appliances](https://www.instagram.com/artusi_appliances)

 www.linkedin.com/company/eurolinx-pty-ltd-t-a-lve/

Australia National Telephone Number 1300 (694 583) New Zealand Telephone Number 64 3 344 5913
Artusi showroom hours: Tuesday to Friday - 9am-5pm, Saturday - 10am-4pm, Sunday and Monday - closed
* Melbourne showroom hours: Tuesday to Saturday - 10am-4pm

[artusi.com.au](https://www.artusi.com.au)

NSW & ACT (Head Office)
48-50 Moore Street
Leichhardt
F 02 8569 4699

QLD
1/42 Cavendish Road
Coorparoo
F 07 3397 0850

WA & NT
Unit 10/55 Howe Street
Osborne Park
F 08 9201 9188

New Zealand
PO Box 11,160
Sockburn Christchurch
F 03 344 5906