

Bastia • LJMO25GXBI

25L Built-In Microwave Oven



Available Colors
Stainless Steel Panel &
Matching Trim Kit

Signature Features

FlatWave Technology

- Seamlessly distributes heat throughout the entire oven for the best cooking results

Flatbed Design

- Flatbed design makes removing grease or oil effortless
- Scratch-resistant and easy-to-clean interior

Grilling Element

- Enjoy crispy food in minutes as the grill function crisps your food on the outside without drying inside

Intuitive Display

- Ease of use with innovative design. Access a variety of features on the LED display panel for optimal performance at the convenience of your fingertips

Conventional
Turntable

Features

- 25L Capacity
- FlatWave Technology
- 900W of Cooking Power
- 5 Power Levels
- 1200W of Grill Power
- 2 Grill Power Levels
- 2 Combi Cooking Levels
- 6 Auto Menu Programs
- LED Display

Convenience

- Clock (24hr)
- Child Safety Lock
- Pre-Set Timer Function
- Completion Beeper
- Auto-Weight Defrost
- Quick-Reheating
- Push handle door

Accessories

- Matching Trim Kit
- 1 Round Wire Grill Rack

Bastia • LJMO25GXBI

25L Built-In Microwave Oven

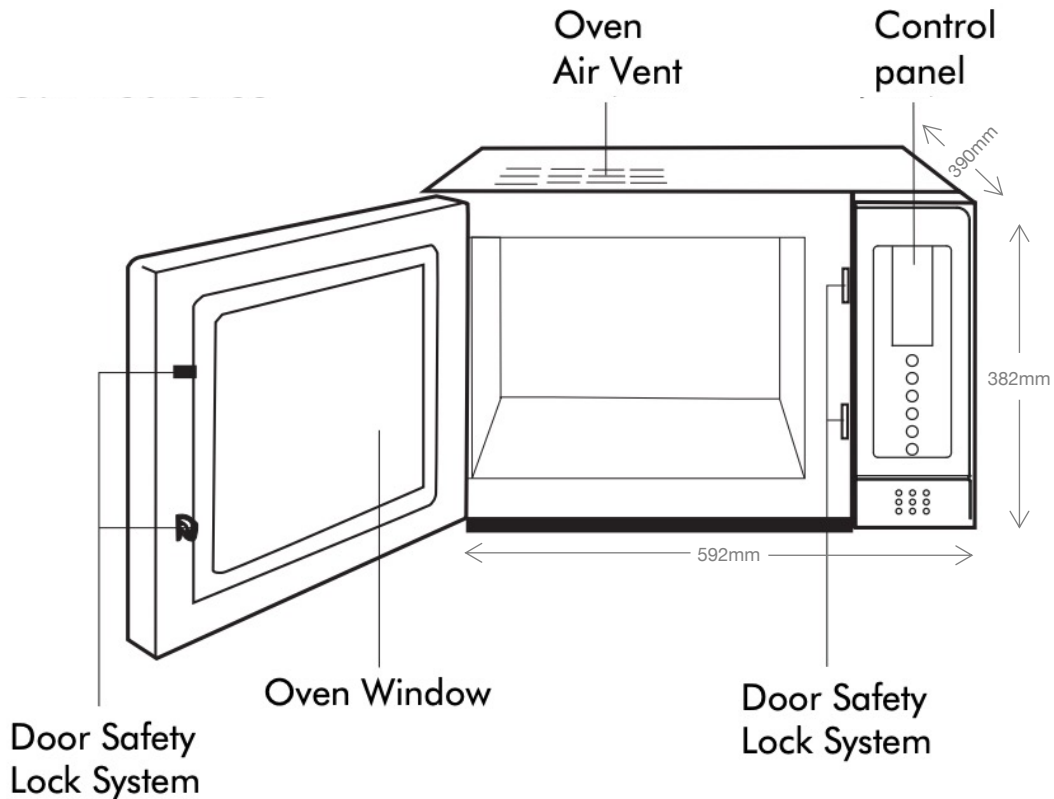

Specifications

- Oven Cavity: 25L
- Microwave Distribution System: Flatbed
- Power Output: 900W
- Grill Power Output: 1200W
- Quick-Reheating
- Weight-Defrosting
- Cooking Controls:
 - 5 Power Levels
 - 2 Grill Power Levels
 - 2 Combi Power Levels
- Control Method: Electronic Touch
- Display: LED (red)
- Light: Incandescent
- Pre-Set Timer Function: 60 Minutes
- Noise Level: <65db
- Operating Frequency: 2450MHz
- Power Consumption: 1400W/10 A
- Power Source: 220-240V / 50 Hz

Warranty

- Two (2) Year Parts and Labor
- *Extend your warranty by registering your product linarie.com.au*

Product Dimensions & Weight

- Outside: 592 (W) x 390(H) x 382 (D) mm
- Cavity: 330 (W) x 212 (H) x 330 (D) mm
- Weight: 16.5 kg (including accessories)

Trim Kit Dimension

- Frame: 592 (W) x 390 (H) x 20 (D) mm
- Cavity: 566-580 (W) x 365-380 (H) x 550 (D) mm

Shipping Dimensions & Weight

- Dimensions: 655 (W) x 440 (H) x 470 (D) mm
- Weight: 18.5 kg

Bastia • LJMO25GXBI

25L Built-In Microwave Oven

Installation

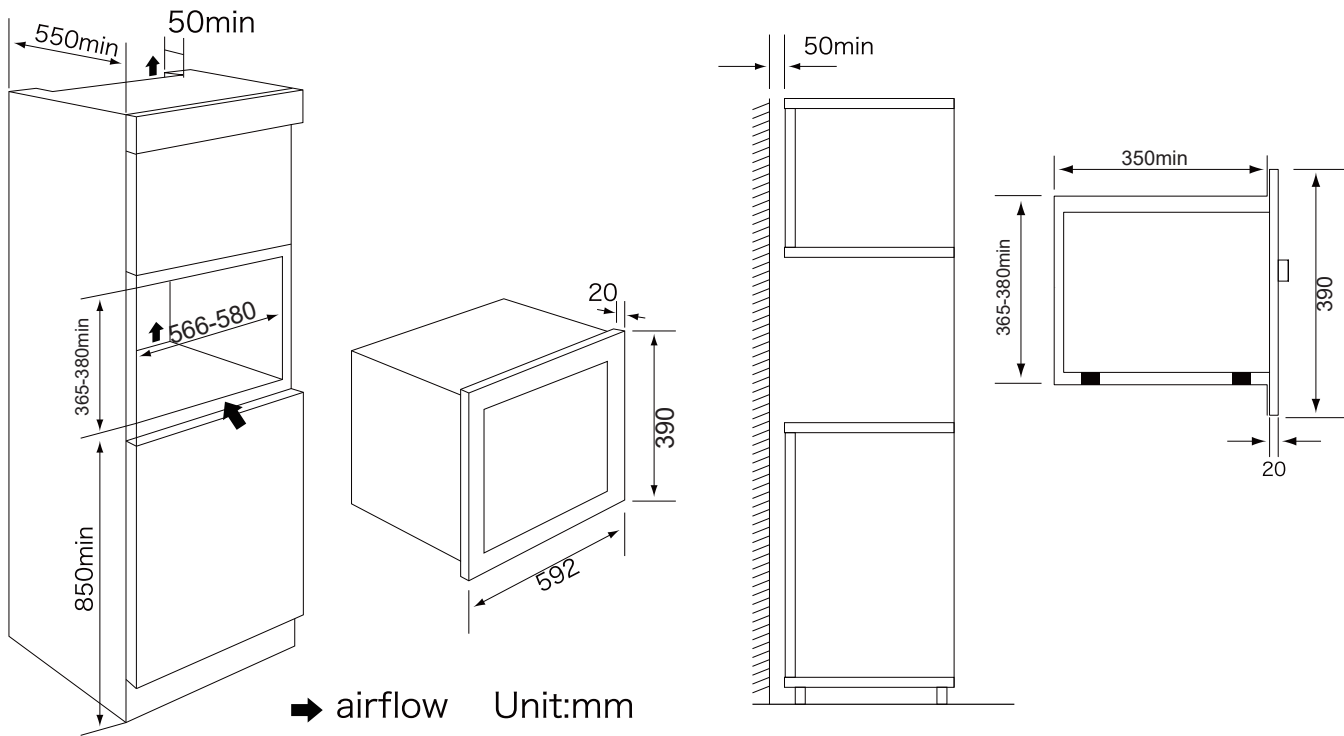

Installation in top cabinet

