

# cooking collection

---

Instructions for use and warranty details

To register your warranty or make a warranty claim, scan this QR code:



Rangehood  
Model No.: RHSO91

 **kLEENmaid**

Dear Customer,

Thank you and congratulations for choosing Kleenmaid.

Your new appliance has been designed and meticulously tested to ensure that it meets all your culinary requirements, and has been carefully manufactured using top quality materials to give you years of reliable performance.

For best results, carefully read the instructions on how your new appliance is to be installed. Correct installation will avoid delays and unnecessary service call costs.

Once installation is complete, please read this instruction manual carefully and get to know the controls and the features of your new Kleenmaid appliance. These simple instructions will enable you to achieve excellent results from the very first time you use it.

Again, congratulations and thank you for choosing The Best You Can Own.

KLEENMAID

## Table of contents

● Technical Specifications	4
● Dimensions	4
● SAFETY: Read this first!	5
● Warnings	6
● Description of Parts	7
● Instruction for use	8
● Installation	8-10
● Cleaning & Maintenance	11-12
● Troubleshooting	13
● Warranty Terms & Conditions	14-15

\*Read the complete manual carefully before installation\*  
The current online version of the User Manual is available on the  
Kleenmaid website (see back cover for details).

## TECHNICAL SPECIFICATIONS

Voltage	220-240V~ 50Hz/60Hz
Rated Power	283W
Lighting Power	1.5W x2
Motor Power	280W
Diameter of air outlet	150mm
Air flow	Max 850m <sup>3</sup> /h (air flow meter)
Noise	57dB(A) at Low Speed

## DIMENSIONS

External Dimensions: W 902x D280x H322 mm

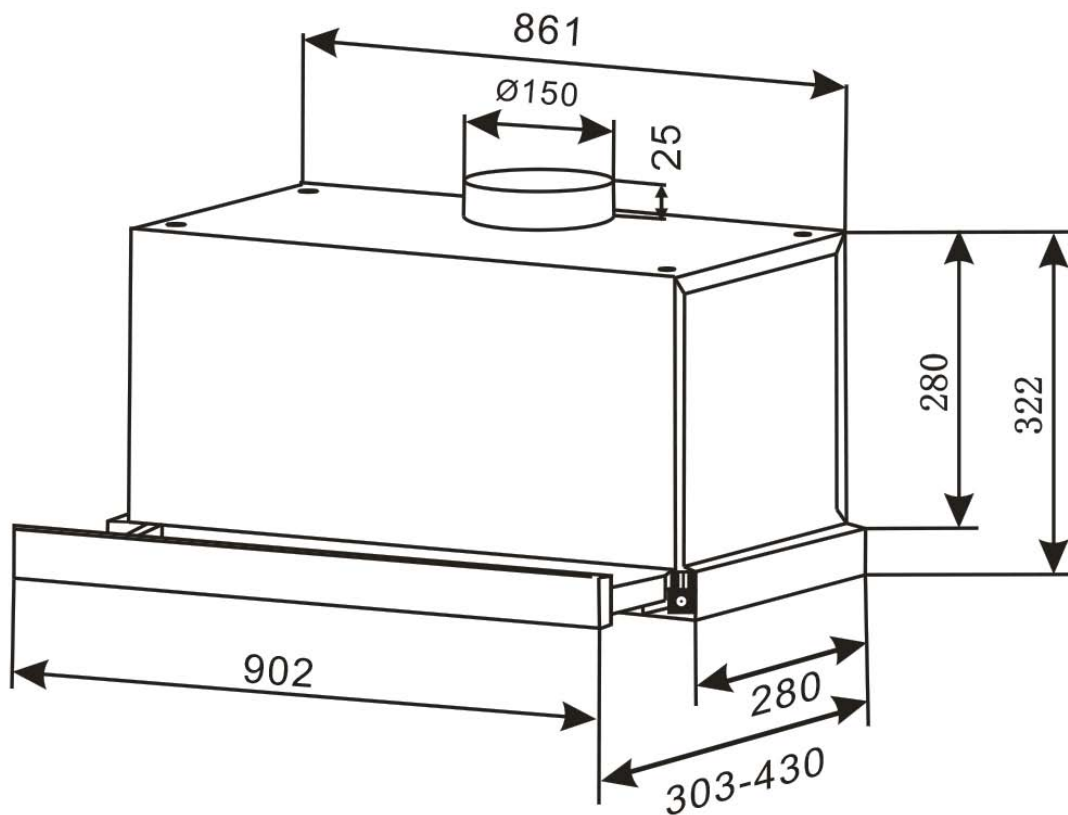

## **SAFETY: Read this First!**

- Do not connect the appliance if there are obvious signs of transportation damage.
- Read this user manual thoroughly before attempting to use this appliance.
- Installation and repair should be attempted only by qualified technical personnel.
- It is dangerous to modify any parts of this appliance.
- The manufacturer declines all responsibility in case of failure to adopt proper safety measures.
- Ensure the location in which this appliance is installed has good, permanent ventilation.
- The safety gap between the rangehood and the hob below must comply with the recommendations of the hob manufacturer. In case of no instructions, a minimum distance of 650mm (or other minimum distance as may be specified by AS ZS 5601 and interpreted by a certified installer) should apply.
- Use an electrical connector with earth that conforms to local standards.
- Check that the voltage in your area is correct before plugging in.
- Multiple plugs and extension cables must not be used. Electrical overload is dangerous and may cause a fire.
- Ensure that the power cord is free from any heat source or sharp objects.
- The appliance should be switched off and the electrical supply disconnected before any cleaning or maintenance work is carried out.
- The electrical connection of this appliance must be connected to earth.

Green & yellow	=	EARTH
Blue	=	NEUTRAL
Brown	=	LIVE



WARNING: IT MUST BE ENSURED THAT THIS APPLIANCE IS CONNECTED ONLY TO A 230VAC +10%/-6% 50Hz MAINS POWER SUPPLY WHICH CONTINUOUSLY COMPLIES WITH THE RELEVANT AUSTRALIAN STANDARD. FAILURE TO DO SO MAY SERIOUSLY DAMAGE THE APPLIANCE AND ANY SUCH DAMAGE IS NOT COVERED BY THE MANUFACTURER'S WARRANTY.



## **Warning**

- This appliance is not intended for use by persons (including children) with reduced physical, sensory or mental capabilities, or lack of experience and knowledge, unless they have been given supervision or instruction concerning use of the appliance by a person responsible for their well being.
- Children must be supervised so they do not play with the appliance.
- There should be adequate ventilation of the room when the rangehood is used at the same time as appliances burning gas or other fuels. (Not applicable to appliances that only discharge the air back into the room.)
- There is a fire risk if cleaning is not carried out in accordance with the instructions.
- Do not flame under the rangehood.
- CAUTION: Accessible parts may become hot when used with cooking appliances.
- The air must not be discharged into a flue that is used for exhausting fumes from appliances burning gas or other fuels.
- Regulations concerning the discharge of air must be fulfilled .
- If the supply cord is damaged, it must be replaced by the manufacturer, its service agent or similarly qualified persons in order to avoid a hazard.
- Cleaning and user maintenance should not be made by children without supervision.

## **Safe disposal of appliances and packaging**

- This appliance and packaging are produced by processes that minimize waste and respect the environment.
- There are model specific accessories (e.g. screws) supplied with the rangehood which should be retained for installation and not discarded with packaging.
- Please help us to continue the protection of the environment by disposing of the packaging in a correct manner.
- Please do not allow young children to play with the plastic bag packaging.
- Before disposing of any old appliances, be sure to cut off the power cord so that others will not be endangered by a defective electric appliance.

## Description of Parts

**A** 2 position rocker switch for selecting motor speed

**B** ON/OFF switch for lamp

**C** Lamps with LEDs

**D** Removeable filters

**E** Slide out extraction panel

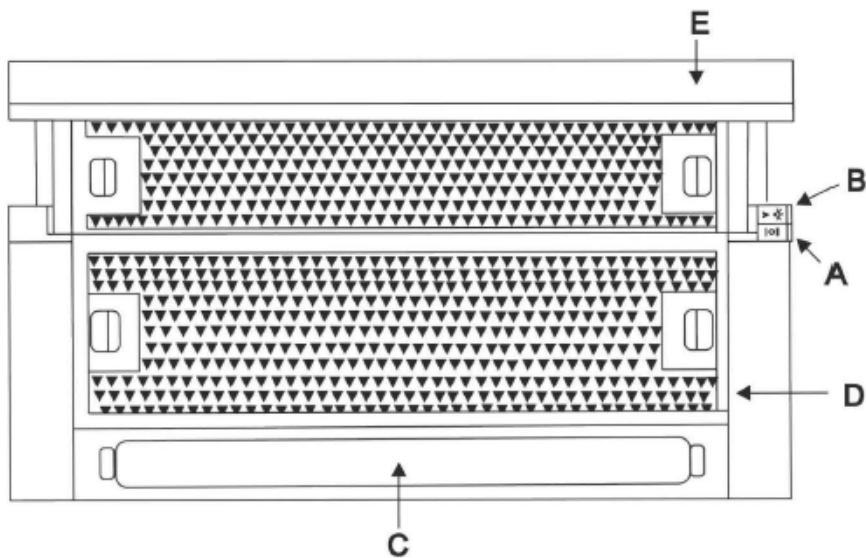

**F** Positions for carbon filters if to be used.

**G-H** Anti return tabs are to be fitted in the outlet mouth, by positioning the locating ends in the holes provided.

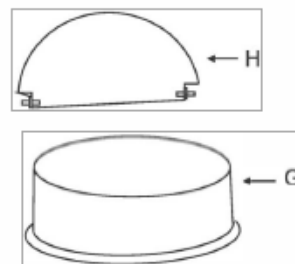
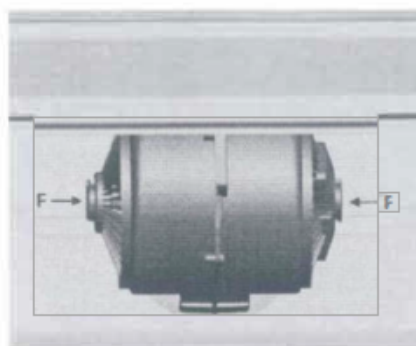

# Instructions for use

Press the button shown in the diagram below, to control the functions of the rangehood. To achieve better fume extraction, it is recommended the rangehood be switched on for a few minutes (approx 3-5minutes) before starting to cook so that the air flow is stable and continuous.

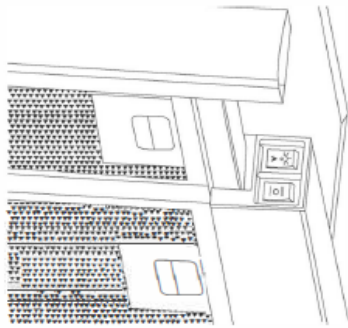

	Speed
I	Low
II	High
⚡	<u>Light</u> ON
0	OFF
A	Automatic

## Installation

NOTE: Before making preparations for or commencing installation, the installer should refer to the current online version of the User Manual, which is available on the Kleenmaid website (see back cover for details).

### Notes:

- Attach the rangehood to the kitchen unit.
- The safety gap between the rangehood and the hob below must comply with the recommendations of the hob manufacturer. In case of no instructions, a minimum distance of 650mm (or other minimum distance as may be specified by AS/NZS 5601 and interpreted by a certified installer) should apply.
- When the rangehood is working at the same time as other non-electrical cooking equipment, the outlet air pressure must not exceed 4 Pa.
- To achieve optimum performance the length of the outlet ducting should not exceed 4 meters, or include more than two 90 angles (elbows). Rigid smooth surface ducting is recommended.
- Although venting to the outside is recommended, carbon filters may be used, which allow the air to be returned to the kitchen through the outlet pipe.
- If the cabinet into which the rangehood is installed is more than the total depth of the rangehood the installer will need to fit an appropriately thick sealing batten to the wall behind the rangehood, equal in width to the rangehood.



## Notes

- Before installation make sure that the household voltage is same as the voltage on the rating label of the rangehood.
- The wall or ceiling on which the rangehood is installed must be strong and flat enough to support the rangehood. The wall shall be non-combustible and the rangehood must not be mounted on a wall made of flammable material such as wood.
- To prevent any fire, please discharge the exhaust gas to a public cold flue (in apartments) or outdoors.
- The air must not be discharged into a flue that is used for exhausting fumes from appliances burning gas or other fuels.
- Do not unpack your rangehood if your kitchen is undergoing decoration as building materials , dust, paint, coatings , and their gases can corrode and tarnish the surface of the range hood. Please install the rangehood after the decoration.
- The rangehood shall be level, firm and steady after the installation.

### Location and height for installation

- Install the rangehood in a dry place without direct sunlight.
- If the rangehood is installed within a cabinet, the latter must be installed with enough space reserved to easily install, disassemble and maintain the rangehood.
- The rangehood shall be installed as close to the outlet of the flue or external wall as possible to shorten the distance between the outlet of the rangehood and the public flue or external wall.
- The rangehood shall be mounted above the stove in parallel and on the same axis.
- The safety gap between the rangehood and the hob below must comply with the recommendations of the hob manufacturer. In case of no instructions, a minimum distance of 650mm (or other minimum distance as may be specified by AS/NZS 5601 and interpreted by a certified installer) should apply.
- The vertical separation distance shall not exceed 750mm so as not to adversely affect the extraction efficiency. See Figure 3.

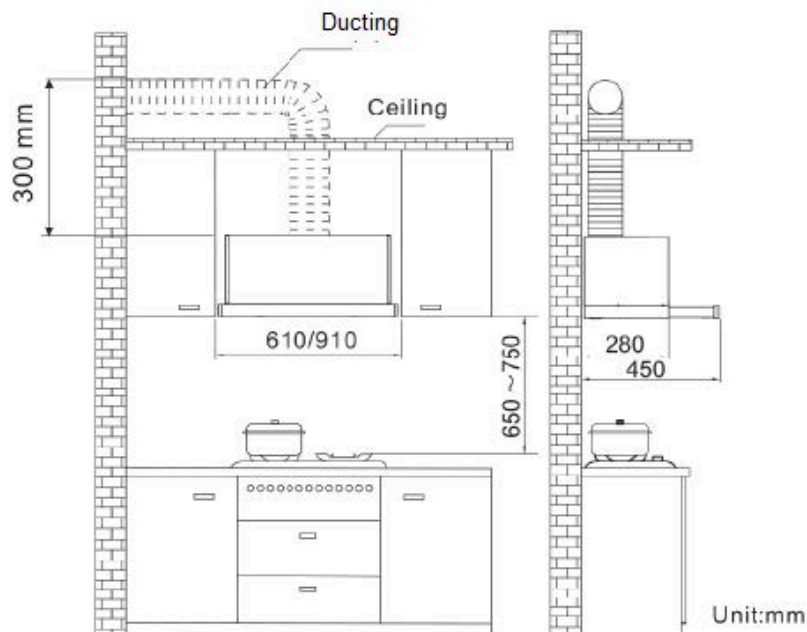

Picture 3

## Drill holes and install rangehood body

Method: Built-in (picture 4)

- Drill four holes of 6mm diameter and a hole of 170mm diameter on the top of the cabinet.
- Install the rangehood under the cabinet and screw tight with supplied M5 screws and gasket.
- Install the mounting board under the rangehood so as to cover the gap between the back of rangehood and cabinet.

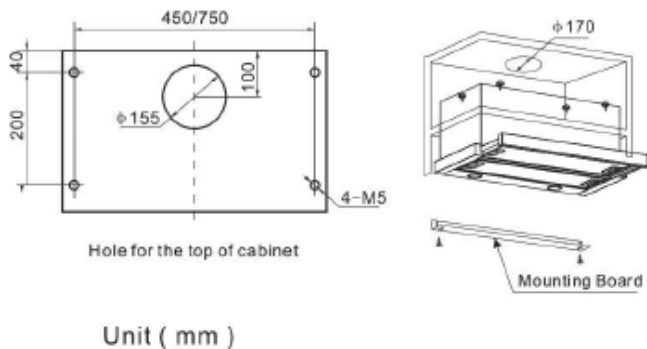

### Option (Recirculation Mode)

Put the carbon filter onto the motor fan system at the two sides (shown as above), then fix them in clockwise direction. Caution:

- 1) The cabinet front door should have an air inlet louvre.
- 2) The distance of the rangehood air outlet to the top of the cabinet should be at least 200mm
- 3) With normal usage the carbon filter should be replaced every 3 mths.

## Installing the rigid smooth surface ducting (not supplied)

- Fix one end of the rigid duct pipe onto the outlet of the rangehood, and connect the other end directly with the public flue or the external wall hole. The connection shall be firmly fixed and sealed.
  - When installing the duct pipe, examine whether the anti-return valves of the rangehood and the public flue outlet (if installing in an apartment) can be operated normally.
  - Avoid too many bends of the duct pipe, and bending angle of less than 90 degrees as this will affect the efficiency of the appliance.
  - Do not connect the duct pipe of this rangehood with any pipe of smaller diameter as this may affect the exhaust.
  - If you need to connect the rigid duct pipe to a public flue, do not insert it too deeply into the public flue, so as to prevent the exhaust resistance from increasing. It is recommended that a check valve is installed at the connection between the duct pipe and the public flue.
- If you need to connect the duct pipe outdoors, it is recommended that a blind window is installed at the connection between the duct pipe and external wall to prevent the outdoor wind from flowing indoors.
- The distance from the top of rangehood to the ceiling should be at least 300mm.

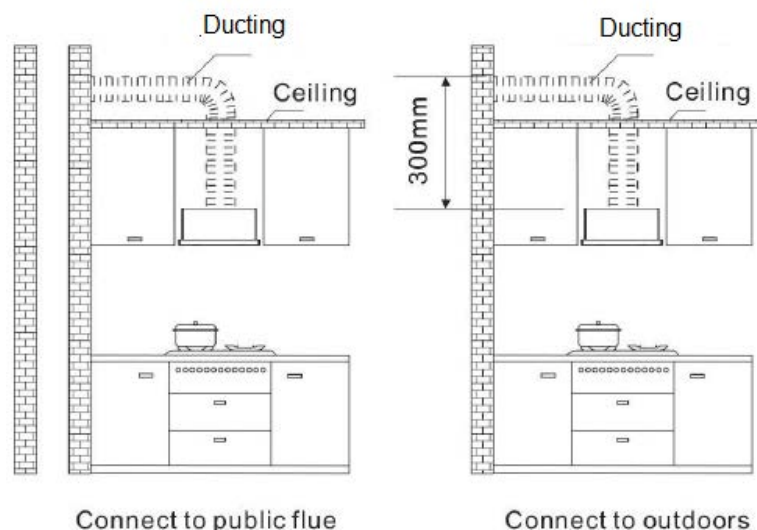

# Cleaning & Maintenance

Before carrying out any cleaning or maintenance activities, ensure that the appliance is disconnected from the mains.

Take note of safety instructions when carrying out cleaning and maintenance.

There is a fire risk if cleaning is not carried out in accordance with the instructions.

## **Cleaning the Rangehood Body**

Moisten a cloth in warm soapy water (40°C approx.) to clean the rangehood, paying special attention to the grids. Afterwards, dry it using a lint-free cloth.

Notes: Never use metallic scouring pads or abrasive products that could damage the surface. Do not use scrapers with metallic surfaces such as knives, scissors etc.

## **Maintenance and Replacement of your Kleenmaid Rangehood Filters**

Your Kleenmaid rangehood has one or both the following types of filters:

### **1. The visible aluminium grease filter, which is present on every rangehood.**

These filters should be removed, cleaned and re-installed at least every three months, and more often if food is regularly fried or grilled. These filters may be cleaned either with a soft-bristled brush in warm soapy water, or in a dishwasher (without other items). Ensure that each filter is completely dry before re-installing it into the rangehood.

### **Filter Cleaning**

Release the anchoring points to withdraw the filters from their locations. Clean the filters by putting them in the dishwasher (without other items), leaving them standing in hot water to simplify the removal of grease or by using appropriate special sprays (protecting the non metallic parts). Once clean, leave them to dry before re-installing.

Notes: Cleaning filters in the dishwasher with harsh detergents may blacken the surface of metallic parts without affecting the gas retaining properties. The filters must be cleaned at least once a month depending on how often the appliance is used. It must be remembered that grease is deposited in the rangehood when cooking, whether it is switched on or not.

Normally these filters will last the life of the rangehood, however if they are damaged in any way, replacements may be purchased by emailing [support@kleenmaid.com.au](mailto:support@kleenmaid.com.au) or calling 02 9310 1207.

**Warning:** It must be ensured that the grease filters are correctly installed whenever the rangehood is operating. Failure to do so may damage the rangehood, and such damage will not be covered by the manufacturer's warranty.

### **2. The internal Kleenmaid Activated Charcoal (or "Carbon") Filter, which should be present on a rangehood which is installed in recirculating mode i.e. not vented outdoors.**

These filters are located inside the rangehood and remove cooking odours from the air. These filters cannot be cleaned and will require replacement. The effective life of the filter depends on the type and amount of cooking you do. Generally the life of these filters is approximately six months. However, always replace the filter when it no longer absorbs odours effectively.

When replacement Kleenmaid Activated Charcoal filters are required they may be purchased by emailing [support@kleenmaid.com.au](mailto:support@kleenmaid.com.au) or calling 02 9310 1207.

# Cleaning & Maintenance

## Replacing the Charcoal Filter

To install the carbon filter (after removing saturated filter) align the motor anchorage with the anchor points of the carbon filter and turn clockwise.



## Changing LEDs

Take care to disconnect the rangehood from the mains power beforehand and check that the LEDs to be replaced are not hot.

Remove the filter support to access the LED.

Use a flat-blade screwdriver to remove the LED from the lamp and separate it from the terminal. Replace with a new LED of the same type with maximum power 1.5W. Reinstall into the rangehood body and replace the filter support.

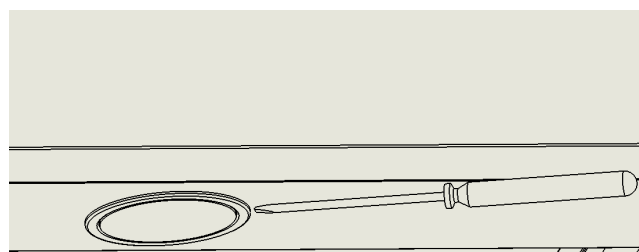

The range hood with LED modules, 2X1,5W, DC12V , 60mm

Name	IL COS D code in according to standard	Max Power	voltage	shape description/picture/nominal dimension
LED	IEC/EN 61231	1,5W	DC12V	Diameter: 60mm 

# Troubleshooting Guide

Symptoms	Possible Cause	Action
Does not function	No electrical supply	Check that the plug is connected
		Check that the main switch is turned on
Poor airflow	Aluminium grease filters clogged	Clean the filters and replace when dry see p11
	Carbon grease filters clogged	Replace carbon filters with new sets see p12
Motor running but no airflow	Butterfly valve jammed	Contact technician
Motor cuts out after a few minutes	High temperature safety device activated	The kitchen is not sufficiently ventilated
	The rangehood is installed too near the cooktop	The hood must be at least 650mm from the cooktop
Strong cooking smell	Carbon filters not installed	In re-circulating mode, carbon filters must be installed
Oil dripping onto stove	Aluminium grease filters saturated	Wash the aluminium grease filters see p11
Whirring sound	Foreign object in contact with fan blade	Contact technician

If the appliance fails to operate correctly during the warranty period please visit our website to request a warranty service (see back cover of this manual for details). When booking a service please provide your Model No.: RHSO91 and the individual Serial Number of your appliance. If you no longer have documentation showing the serial number it can be found on the appliance rating label on the underneath right hand side of the retractable/sliding section of the rangehood. To access the rating label remove the grease filters as per instructions for cleaning on page 11.

# KLEENMAID WARRANTY

## TERMS AND CONDITIONS

1. Compass Capital Services Pty Ltd ABN 96 138 214 525 trading as Kleenmaid will provide parts and labour to you the customer as set out herein.
2. Kleenmaid may engage a Service Agent to provide service under this warranty.
3. Kleenmaid's Products come with guarantees that cannot be excluded under the Australian Consumer Law. You are entitled to a replacement or refund for a major failure and for compensation for any other reasonably foreseeable loss or damage. You are also entitled to have the goods repaired or replaced if the goods fail to be of acceptable quality and the failure does not amount to a major failure.
4. The benefits given to you under this Kleenmaid Warranty are in addition to other rights and remedies to which you may be entitled under the Australian Consumer Law in relation to the Product to which this Kleenmaid Warranty relates. Subject to the conditions below, the Product is warranted by Kleenmaid and/or its agents to be free from defects in materials and workmanship for the Warranty Period for normal Domestic Use.
5. Product Identification: -
  - a. Kleenmaid reserves the right to reject claims for any services or work where you cannot produce for verification the serial number and a proof of purchase for the Product (including but not limited to the original invoice).
  - b. this Kleenmaid Warranty will be voided if the serial number for the Product cannot be verified. This is not intended to exclude, restrict or modify any right or remedy to which you may otherwise be entitled under the consumer guarantee provisions of the Australian Consumer Law.
  - c. in the event that a request for repair is made against this Kleenmaid Warranty where the serial number for the Product cannot be verified or you cannot produce for verification a proof of purchase for the Product (including but not limited to the original invoice), the repairer will not carry out any repairs on the Product and you will be charged a service call-out fee.
6. What is covered by this Kleenmaid Warranty: -
  - a. the Product is covered for faulty workmanship or parts that have failed under normal Domestic Use.
  - b. Kleenmaid and/or its agents will determine by objective testing if there are any defects in the Product and/or faulty workmanship.
  - c. this Kleenmaid Warranty is only applicable if repairs on Products are carried out within Mainland Australia.
  - d. this Kleenmaid Warranty: -
    - i. covers a Product purchased as new, manufactured for use in Mainland Australia;
    - ii. commences from the date of delivery of the Product;
    - iii. provides for the labour and replacement parts necessary to maintain the Product in good operating condition as specified in this Kleenmaid Warranty, however, if repair is needed because of Product failure during normal Domestic Use, Kleenmaid has the option to repair or replace the defective Product or part of the Product with a product or part of like kind and quality. A replacement part may be new or reconditioned of like kind and quality and may cost less than the original Product purchased and no charges or refunds will be made based on the replacement product or part cost difference; and
    - iv. is only applicable when the Product is used and operated in accordance with the Manufacturer's instructions.
7. What is not Covered by this Kleenmaid Warranty (excluded):-
  - a. any damage or failure to or of the Product or part of the Product:
    - i. due to the Product being inadequately serviced to manufacturer's recommendations;
    - ii. resulting from environmental conditions including and not limited to dirt, dust, rodents, insects, rust, corrosion, salt built-up, or of in any part of the Product;
    - iii. resulting from excessive use but fair wear and tear is excepted;
    - iv. resulting from installation by an unqualified or uncertified tradesperson;
    - v. resulting from poor or incorrect installation including and not limited to positioning and externally fitted equipment such as plumbing and drainage, cabling, antennae or due to incompatibility of connected equipment;
    - vi. caused by overheating as a result of sitting or positioning of the Product, where there is no provision for adequate ventilation or adequate protection from excessive dust;
    - vii. if the Product has been dismantled, repaired or serviced by any person other than someone authorised by Kleenmaid or its agents or representatives;
    - viii. caused by power surges or spikes, including and not limited to, mains power and telecommunications connections, or to other unspecified sources, incorrect power current, voltage fluctuation, amperage fluctuation, rust or corrosion;
    - ix. if the Product is dropped, collision of the Product with another object, use for which the Product is not designed, damage to the Product caused by your own negligence, accidental or deliberate misuse of the Product by you, theft, abuse, vandalism, flood, fire, earthquake, electrical storms or any other act of God or any war related events; or
    - x. due to the introduction of abnormal heat loads to the Product;
  - b. costs of attendance and testing where no fault or defect covered by the terms of this Kleenmaid Warranty is identified in the Product;
  - c. initial setup and installation of the Product;
  - d. normal maintenance costs and costs incurred through the installation of items listed as requiring periodic replacement;
  - e. Products with removed or altered serial numbers;
  - f. broken or cracked glass other than transport damage to the initial point of delivery;
  - g. consumables such as but not limited to bulbs/globes, seals, filters, batteries and remote controls;
  - h. removal and reinstallation of an internal component not performed by an authorised Kleenmaid agent or representative or authorised service centre;
  - i. cosmetic or structural items; or
  - j. any failures due to interference from or with other products and/or sources.
8. This Kleenmaid Warranty ceases if: -
  - a. the Product ceases to carry the original manufacturer's serial number or is sold at an auction;
  - b. the Product is rented; or
  - c. there is failure to pay monies owing on invoices as a result of non-warranty work being carried out at the request of the end user as per point 16 below.

9. Service under this warranty may be limited by the area in which you live. Service to remote and regional areas may incur additional travel costs which will be payable by you. You will be advised of this at the time you make a claim and Kleenmaid arranges to attend your premises.
10. Neither Kleenmaid nor its representatives provide loan equipment under the terms of this Kleenmaid Warranty.
11. Any unauthorised access to the internal hardware of the Product will void this Kleenmaid Warranty.
12. Repair Notice: Products presented for repair may be replaced by refurbished Products of the same type rather than being repaired. Refurbished parts may be used to repair the Products.
13. Replacement items are "like for like" and is not "new for old" and does not indicate in any way that a faulty Product will be replaced with a new part or unit. "Like for like" may either be a quality checked, refurbished or reconditioned unit of the same or later batch of model/size/specifications
14. The cost of making a claim under this Kleenmaid Warranty is not covered by Kleenmaid, including any costs of transportation or travel expenses between your home and your nearest authorised service agent.
15. Kleenmaid accepts no liability for items that are lost, damaged, or stolen as a result of freight, transport or storage. If you are required to transport the Product to an authorised service centre, you must ensure that it is securely packed and insured.
16. On Public Holidays or other periods when regular business and wholesale operations are temporarily ceased, repairer availability and warranty response times may extend beyond the standard response times due to the unavailability of repairers and parts.
17. For any repair performed on a Product under this Kleenmaid Warranty where no fault can be found, or the item is deemed by Kleenmaid or an authorised agent, to be not faulty under this Kleenmaid Warranty, or the repair or fault is not covered under this Kleenmaid Warranty, a 'No Fault Found' fee is payable by you. Kleenmaid will advise you of this cost and seek your agreement to pay such costs before commencing such repairs.
18. Any repairs or services required that are outside the terms and conditions of this Kleenmaid Warranty can be carried out at your request at your cost (including where the Product has not been installed or set up correctly). Kleenmaid will always advise you of this cost and seek your agreement to pay such costs before commencing such repairs. A credit card may be required prior to the commencement of such services.
19. Extra charges will be payable by the customer should the Product not be readily accessible without special equipment, such as but not limited to cranes and lifts or should the Product be installed in a position that service access is blocked and/or repair work is not possible without uninstalling the Product to gain access.
20. You, the customer, may be entitled to purchase an extended warranty in respect of the Product. Any extended warranty will not be issued by Kleenmaid but by a third party. Any extended warranty services will be provided directly by the third party as principal and not as agent for Kleenmaid, under their extended warranty terms and conditions and not under this Kleenmaid Warranty.
21. To make a claim under this Kleenmaid Warranty, please have your proof of purchase and the serial number of the Product ready and call (02) 9310 1207 during business hours.
22. This Kleenmaid Warranty is given by:  
Name: Compass Capital Services Pty Ltd ABN 96 138 214 525 trading as Kleenmaid  
Business address: Level 2, Suite 3, 204 Botany Rd, Alexandria NSW Australia 2015  
Telephone: (02) 9310 1207
23. Definitions:
  - a. **Australian Consumer Law** means the *Competition and Consumer Act 2010* (Cth).
  - b. **Domestic Use** means use of the Product for personal, domestic or household purposes.
  - c. **Kleenmaid** means Compass Capital Services Pty Ltd ABN 96 138 214 525 trading as Kleenmaid.
  - d. **Mainland Australia** means the following States and Territories of Australia: New South Wales, Victoria, South Australia, Western Australia, Queensland, Tasmania, Northern Territory, Australian Capital Territory.
  - e. **Product** means the appliance sold by Kleenmaid to you as evidenced by the original purchase invoice.
  - f. **Service Agent** means any independent service agent engaged by Kleenmaid to carry out any repair or service under this warranty.
  - g. **Warranty Period** means for domestic use and for Products purchased on or after 1 January 2019 the period of 60 months, otherwise 36 months. For non-domestic use 12 months or such alternative period as may be specified.

**UPDATE NOTICE:** This Kleenmaid Warranty is current as at 1 December 2022 but is subject to variation from time to time. For the latest version of the Kleenmaid Warranty, please see our website <https://kleenmaid.com.au/warranty/> or phone us on (02) 9310 1207.

## Other products available in the Kleenmaid range of appliances

---

- | Washing machines
- | Clothes dryers
- | Dishwashers
- | Ovens
- | Cooktops
- | Steam ovens
- | Microwave ovens
- | Built in espresso coffee machines
- | Rangehoods
- | Freestanding ovens
- | Refrigerators & Freezers
- | Beverage Serving Cabinets
- | Water Dispensers
- | Vacuum Cleaners

To register your warranty or make a warranty claim, scan this QR code:



Compass Capital Services Pty Limited  
trading as Kleenmaid  
ABN 96138214525

Level 2, 204 Botany Road Alexandria  
NSW 2015



Register your Kleenmaid  
Appliances Warranty  
[www.kleenmaidwarranty.com.au](http://www.kleenmaidwarranty.com.au)



Request a Warranty Service  
[www.kleenmaidwarranty.com.au](http://www.kleenmaidwarranty.com.au)

E: [warranty@kleenmaid.com.au](mailto:warranty@kleenmaid.com.au)

Please download the current User Manual for this  
appliance at [www.kleenmaid.com.au](http://www.kleenmaid.com.au)

 **kleenmaid**