

Top Mount Refrigeration User Manual

KTB2302, KTB2502, KTB2802

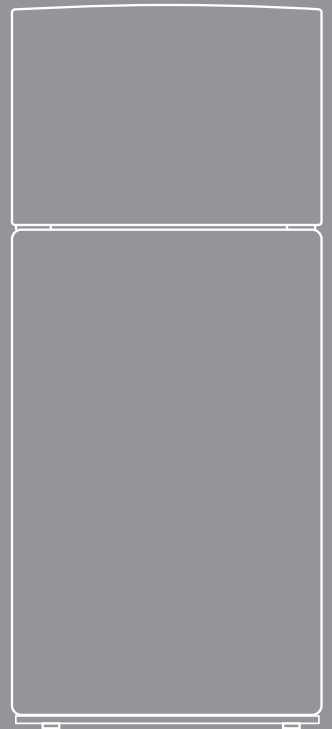

Australians love
a Kelvinator



Congratulations

Dear customer,

Congratulations and thank you for choosing our refrigerator. We are sure you will find your new appliance a pleasure to use. Before you use the appliance, we recommend that you read through the entire user manual, which provides the description of the appliance and its functions.

To avoid the risks that are always present when you use an electrical appliance, it is important that the appliance is installed correctly and that you read the safety instructions carefully to avoid misuse and hazards.

We recommend that you keep this instruction booklet for future reference and pass it on to any future owners.

After unpacking the appliance, please check that it is not damaged. If in doubt, do not use the appliance but contact your local customer care centre.

Conditions of use

This refrigerator is designed and intended to be used in normal domestic applications only.

important

CHECK FOR ANY DAMAGES OR MARKS

If you find the refrigerator is damaged or marked, you must report it within 7 days if you wish to claim for damage/marks under the manufacturer's warranty. This does not affect your statutory rights.

environment

Information on disposal for users

- Most of the packing materials are recyclable. Please dispose of those materials through your local recycling depot or by placing them in appropriate collection containers.
- If you wish to discard this product, please contact your local authorities and ask for the correct method of disposal.

Please ensure you read the instruction manual fully before you call for service, or a full service fee could be applicable.

Record model and serial number here:

Model number:

Serial number:

Contents

Important safety information	3
Installation	5
Top freezer features	6
Temperature control	7
Door alarm	7
LED lighting	7
Features	8
Door storage bins	8
Crisper bin	8
Food storage guide	9
Appliance noise	10
Troubleshooting	11
Notes	12
Warranty	15

Important safety information

Please read the user manual carefully and store in a handy place for later reference. Pass the user manual on to new owners of the refrigerator.

The symbols you will see in this booklet have these meanings



warning
This symbol indicates information concerning your personal safety.



caution
This symbol indicates information on how to avoid damaging the refrigerator



important
This symbol indicates tips and information about use of the refrigerator



environment
This symbol indicates tips and information about economical and ecological use of the refrigerator



- When you dispose of your old refrigerators and freezers, remove any doors. Children can suffocate if they get trapped inside.
- This appliance is not intended for use by persons (including children) with reduced physical, sensory or mental capabilities, or lack of experience and knowledge, unless they have been given supervision or instruction concerning use of the appliance by a person responsible for their safety. Children should be supervised to ensure that they do not play with the appliance.
- Do not use a steam cleaner. If live components come into contact with condensing steam, they may short-circuit or cause an electric shock.
- Do not use mechanical devices or other means to accelerate the defrosting process other than those recommended by the manufacturer.
- This appliance contains insulation formed with flammable blowing gases. Avoid safety hazards by carefully disposing of this appliance.

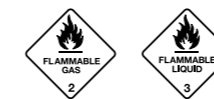

- If pressurised aerosol containers bear the word 'flammable' and/or a small flame symbol, do not store them inside any refrigerator or freezer. If you do so you may cause an explosion.

R600a refrigerant warning

- This appliance contains flammable R600a refrigerant. Avoid safety hazards by carefully installing, handling, servicing and disposing of this appliance. If your appliance contains R600a it will be indicated on the rating plate inside the appliance.
- Ensure that the tubing of the refrigerant circuit is not damaged during transportation and installation.
- In the event any damage accidentally occurs, keep the appliance away from open fires and any devices that produce sparks or arcs and luminaries during normal or abnormal operation, and unplug the appliance at the powerpoint. Call authorised service for necessary action and advice.
- Leaking refrigerant may ignite vent area if leak occurs.
- The room for installing appliance must be at least 1m³ per 8g of refrigerant. The amount and type of refrigerant in the appliance can be found on the rating plate inside the appliance.
- In Queensland the authorised service person MUST hold a gas work authorisation for hydrocarbon refrigerants to carry out servicing or repairs which involve the removal of covers.
- Do not damage the refrigerant circuit.
- Do not use electrical appliances inside the food storage compartments of the appliance, unless they are of the type recommended by the manufacturer.



warning
It is hazardous for anyone other than an authorised service person to service this appliance. In Queensland the authorised service person MUST hold a gas work authorisation for hydrocarbon refrigerants to carry out servicing or repairs which involve the removal of covers.



Stable footing

When your refrigerator is in place, you need to stabilise it. Lift the front of the refrigerator to take the weight off each stability foot and make small quarter turns to each foot until it is in firm contact with the floor. If you intend to move the refrigerator, remember to wind up each foot so that you can move it freely. Repeat the process of the foot adjustment once you have settled on the new location of the refrigerator.

Side View

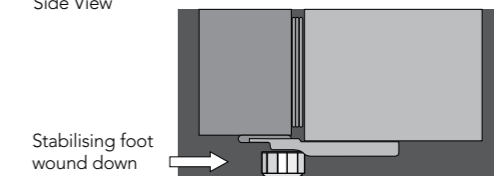





















General warnings

Read the following carefully to avoid damage or injury.

 This symbol indicates never to do this

 This symbol indicates always do this

It is important to use your refrigerator safely. Check these safety points before using your refrigerator.

-  The appliance must be plugged into its own dedicated 220-240V, 50Hz AC electrical outlet.
-  The plug must be accessible when the refrigerator is in position.
-  It is essential the powerpoint is properly earthed to ground. Consult a qualified electrician if you are unsure.
-  Don't use extension cords or adapter plugs with this refrigerator.
-  If the supply cord is damaged, it must be replaced by the manufacturer, its service agent or similarly qualified persons in order to avoid a hazard.
-  Unplug the appliance before cleaning and before changing the light bulb to avoid electric shock.
-  Never unplug the refrigerator by pulling the electrical cord as this may damage it. Grip the plug firmly and pull straight out.
-  Choose a location for your refrigerator that isn't too cold. The ambient room temperature should be above 10°C.
-  Stand your refrigerator in a dry place – avoid areas of high moisture or humidity.
-  Don't put the refrigerator in frosty or unprotected areas like a garage or on the verandah.
-  Don't plug your refrigerator into a timer fitted to the powerpoint.
-  Do not put the refrigerator in direct sunlight, near stoves, fires or heaters.
-  Do not put the refrigerator on an uneven surface.
-  Do not store flammable materials on or under the appliance, e.g. aerosols.
-  Do not store explosive substances such as aerosol cans with a flammable propellant in this appliance.
-  Never store fizzy drinks in the freezer compartment.
-  Never try to repair the refrigerator yourself, only use a qualified or authorised service person for repairs.
-  Never use electric heaters or dryers to defrost the freezer because you can receive an electric shock.
-  When transporting and installing the refrigerator, care should be taken to ensure that no parts of the refrigerating circuit are damaged.
-  Keep ventilation openings in the appliance enclosure or in the built-in structure clear of obstruction.

 When installed correctly, your refrigerator should:

- Have adequate space at the back and sides for air circulation (refer to page 5).
- Be vertically aligned to the surrounding cupboards.
- Have doors that will self-close from a partially open position.

NOTE: You must read these warnings carefully before installing or using the refrigerator. If you need assistance, contact your Customer Care Department. The manufacturer will not accept liability, should these instructions or any other safety instructions incorporated in this book be ignored.

Installation

Clean the refrigerator thoroughly according to instructions and wipe away any dust that has accumulated during shipping.

Check that the floor is level. If it is not, adjust the stabilising foot so that the refrigerator is level and stable.

We recommend that the refrigerator be turned on and left to run for two to three hours before placing any food inside it. This will allow you to check that it is operating properly and there is adequate cool air in the freezer.

Installation clearances

- Allow a minimum of 30mm clearance on both sides of the refrigerator.
- Allow a minimum of 50mm clearance at the back of the refrigerator.
- Allow a minimum of 10mm clearance above the hinge cover.
- If you do not have a cupboard with a rear gap, the recommended clearance above the refrigerator is 90mm.
- When positioned in a corner, the clearance must be at least 350mm on the hinge side to allow the door to open smoothly so that bins and shelves can be removed easily.

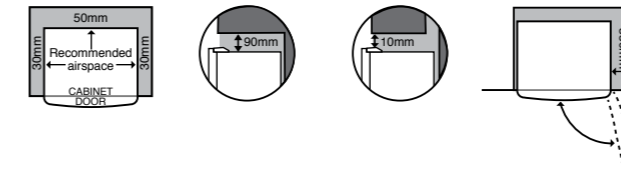

NOTE: Refrigerator doors on all models are designed to sit proud of cabinetry (not flush). In installations where both sides and the rear of the refrigerator are not enclosed by cabinetry eg the refrigerator is placed against a wall, the clearance between the rear of the refrigerator and the wall should not be greater than 75mm.

Initial start up

When in operation, the outside of the refrigerator will feel warm, particularly at start up. This is normal.

Avoid placing food against air outlets as this will impede air circulation.

A light frosting will occasionally occur on the cold interior of the freezer if the door is opened frequently. This is normal and the frost will disappear after a few days in most climates.

Make sure that the freezer and fresh food doors are fully closed after you have loaded or removed food from these compartments. If the doors are left partly opened, a heavy frost will coat the inside of the freezer. If this occurs, remove the frost. Ensure that all doors are properly closed to prevent frost from reappearing.

Your refrigerator uses energy efficient components that may produce different noises from your old refrigerator. Occasionally, a gurgling sound of refrigerant flowing or sound of parts expanding or contracting can be heard. These noises are quite normal. Refer to page 10 for more details on product noises.

Cleaning

Exterior

Clean the refrigerator with only lukewarm soapy water and a soft cloth. Rinse the clean water and then wipe the surface with a soft clean cloth to remove any soap residue.

Interior

Clean the refrigerator interior regularly. Turn power off. Wipe the interior with a soft cloth and lukewarm soapy water. Thoroughly dry all surfaces and removable parts. Avoid getting water on the refrigerator controls. If you have taken out any removable parts, replace them and switch on the power before re-stocking the refrigerator. Wipe away thoroughly any food spills.

Keep door seals clean

Ensure that the door seals are always clean. Sticky food and drinks can cause seals to adhere to the cabinet and may cause tear when opening the door. Wash seals with lukewarm soapy water. Rinse thoroughly and dry

warning

Never use hot water, solvents, commercial kitchen cleaners, aerosol cleaners, metal polishers, caustic or abrasive cleaners or scourers to clean the appliance as they will damage it. Many commercially available cleaning products and detergents contain solvents that will damage your refrigerator. When cleaning, use only a soft cloth and lukewarm soapy water.

Top freezer features

KTB2302, KTB2502, KTB2802

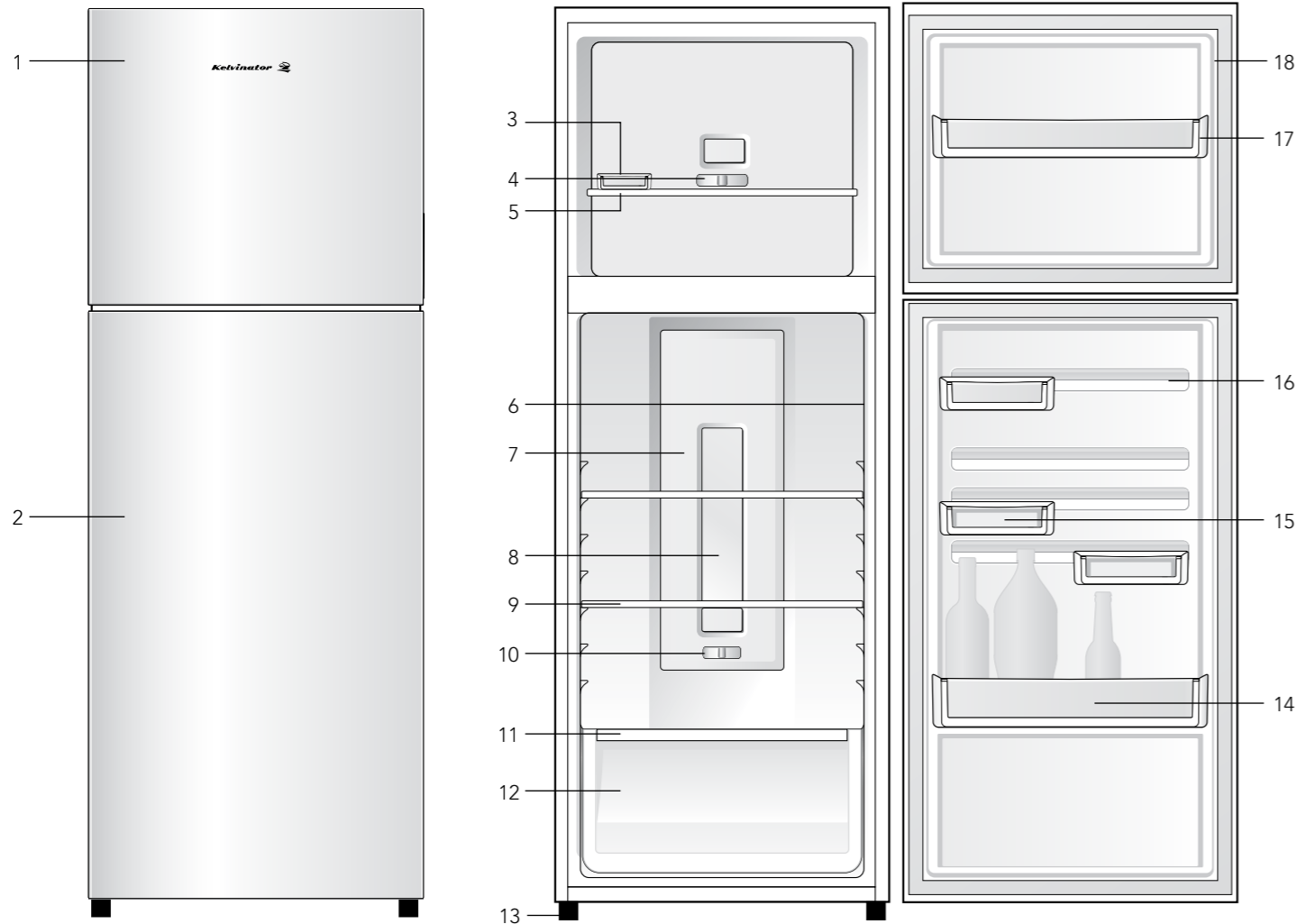

The details of the refrigerator feature:

- | | |
|---------------------------------------|---------------------|
| 1 Freezer Door | 11 Humidity Slide |
| 2 Food Door | 12 Crisper |
| 3 Ice Tray | 13 Adjustable Feet |
| 4 Temperature Control (Freezer) | 14 Bottle Door Bin |
| 5 Freezer Shelf | 15 Door Bins |
| 6 Light Switch | 16 Slide Rails |
| 7 Multiflow | 17 Freezer Door Bin |
| 8 Refrigerator Light | 18 Gaskets |
| 9 Adjustable Glass Shelves | |
| 10 Temperature Control (Refrigerator) | |

Temperature control

When you first turn on the refrigerator, set both the refrigerator and freezer temperature control to MID.

Please refer to the below section for information on adjusting the refrigerator and freezer temperature.

i important

Changing settings

When you change the temperature settings, make small adjustments and wait 24 hours before assessing whether you need to make any further changes.

Refrigerator temperature adjustment

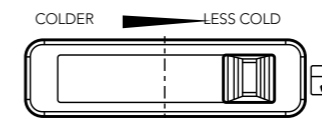

1. Select the refrigerator control.
2. Slide the control to the left to set Colder.
3. Slide the control to the right to set Less Cold.

Adjusting the freezer temperature

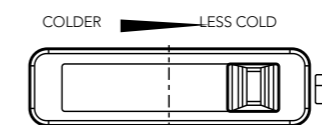

1. Select the freezer control.
2. Slide the control to the left to set Colder.
3. Slide the control to the right to set Less Cold.

i important

Setting the freezer temperature to colder is not recommended for normal or very hot climate conditions as this will limit the cooling capacity to other sections of the refrigerator. In very cold climate, the freezer will need to be set colder.

Door alarm

If the refrigerator door is left open longer than two minutes, a buzzer will sound. Re-set the alarm by pressing the light switch.

LED lighting

Your refrigerator is fitted with long life LED lighting. In the unlikely event the LED lights should ever fail, then the LED lights need to be serviced by the manufacturer, its service agent or similarly qualified personnel in order to avoid a hazard. Refer to page 15 for contact details.

Features

Door storage bins

Both the refrigerator and freezer have door storage bins. You can adjust the refrigerator bins to meet different storage needs. All the door bins are completely removable for cleaning. If you want to remove or adjust a bin, lift and tilt to remove. To replace, tilt the top and push bin down until the support lugs lock it in place.

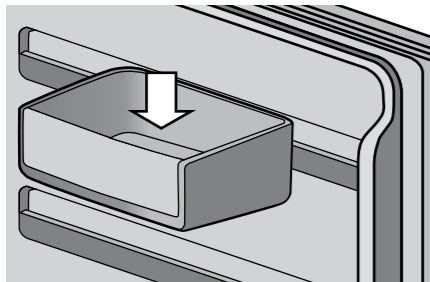

Crisper bin

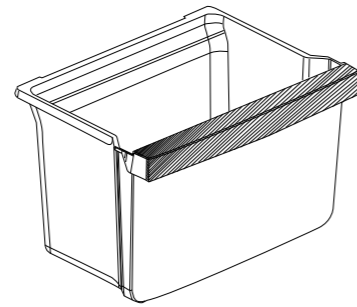

Storing vegetables

Use the crisper bin to store vegetables, fruits or small items. You can adjust the humidity inside the bin by sliding the humidity control.

Storing fruits and small items

You can store fruits in the crisper bin, but do remember to lower the humidity via the humidity control. The humidity can be adjusted by the sliding the lever on the humidity control.

Food storage guide

Category	Product	Refrigerator	Freezer	Storage Tips
Meat	Sausage and mince	1-2 Days	2-3 Months	Keep cold meat at the back of the refrigerator where it is coldest.
	Chops and steak	3-4 Days	4-6 Months	
	Cold meats	3-5 Days	4-6 Months	Plastic can cause meat to sweat if stored in refrigerator for more than a day.
	Cuts for roasting	3-5 Days	12 Months	Cuts for roasting can take up to 48 hours to defrost properly. Transfer frozen cuts to the refrigerator 2 days before use.
Poultry	Chicken	1-2 Days	2 Months	If poultry takes on a smell or colour you are unsure about it is best to throw it out.
	Roast chicken	3-5 Days	12 Months	
	Eggs	6 Weeks	Not suitable	Whole eggs are not suitable for freezing slightly beaten eggs may be frozen for four months.
Seafood	Whole fish and fillets	2-3 Days	2 Months	Store in an airtight container or foil.
	Lobster and crabs	1-2 Days	2 Months	
	Prawns	1-2 Days	2 Months	Never freeze prawns in salty water as this will dehydrate the flesh.
Dairy	Milk	Until expiry dates	Not suitable	If dairy takes on a smell or colour and you are unsure about it, it is best to throw it out.
	Yoghurt	7-10 Days	Not suitable	
	Hard cheese	2 Weeks-2 Months	2 Months (Grated)	Depending on the variety hard cheese can last from 2 weeks to 2 months
	Soft cheese	1-2 Weeks	Not Suitable	
	Butter	8 Weeks	12 Months	
Fruit & Vegetables	Every fruit and vegetable has a different shelf life. Some stay fresh for a couple of days e.g. beans, others can last for a couple of months e.g. onions.		8-12 Months When freezing chop and blanch in small portions.	Keep vegetables in the crisper and away from the air vents to avoid freezing. If you wash fruit and vegetables before storing them make sure they are dry or wrap in absorbent paper before storing in the refrigerator as this can make them susceptible for rotting.
				Try to keep fruit and vegetables separated as fruits that give off high levels of ethylene (the ripening agent) can prematurely ripen and spoil surrounding vegetables.

i important

Please note, use this information as a guide only, actual storage times will vary depending on how you use your refrigerator, climatic conditions and the freshness of the food.

Appliance noise

Your new refrigerator may make sounds that your old one didn't make. Because the sounds are new to you, you might be concerned about them. Most of the new sounds are normal. Hard surfaces, like the floor, walls and cabinets, can make the sounds seem louder than they actually are. The following describes the kinds of sounds and what may be making them."

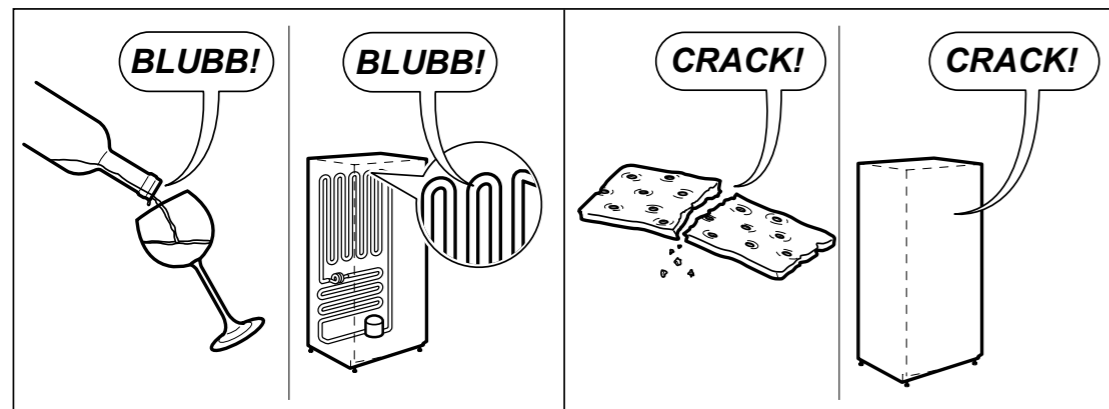
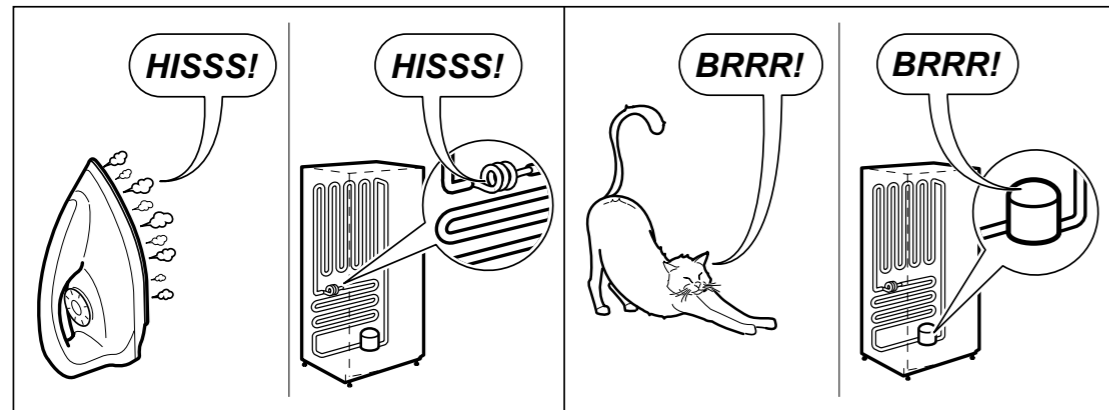
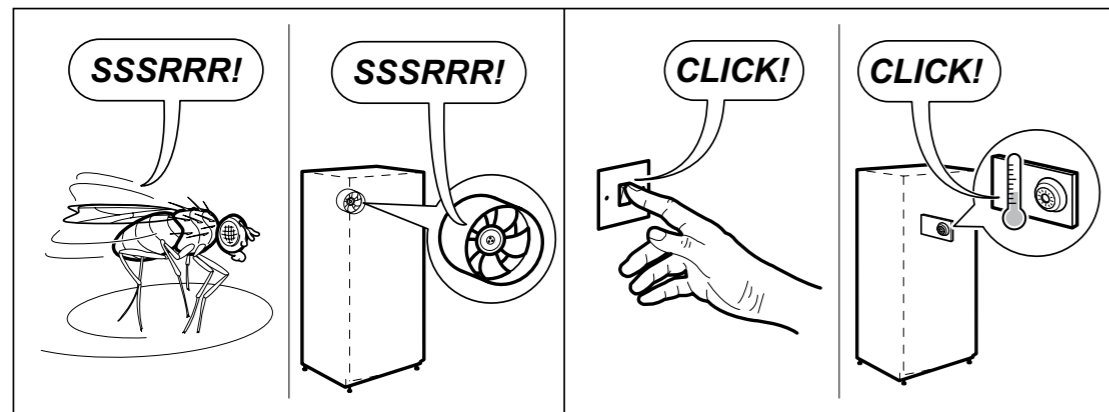
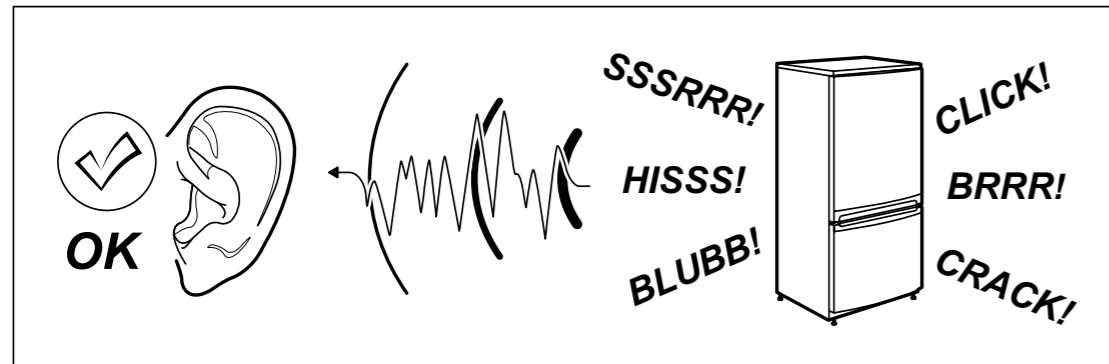

Troubleshooting

If you think something may be wrong with your refrigerator, you can carry out some easy checks before calling for service. You may locate the problem, sparing yourself from inconvenience, saving time and money.

Problem	Solution
When your appliance is not operating	<ul style="list-style-type: none"> Check that the power cord is plugged into the power outlet properly and that the outlet is switched 'ON'. Try running another appliance from the power outlet. If no power is coming from the outlet you may have blown a fuse or tripped a circuit of your household power supply. Try adjusting the temperature control to a slightly "colder" position. It is normal for the freezer fan NOT to operate during the automatic defrost cycle, or for a short time after the appliance is switched on.
When there is refrigerator/freezer noise	<p>Modern refrigerators/freezers with increased storage capacity use high speed compressors. These can provide a seemingly high level of sound which is quite normal. Normal operational sounds include:</p> <ul style="list-style-type: none"> Occasional gurgling, similar to water boiling. Air flow noise (air circulates because of a small fan). A popping noise heard during automatic defrost. <p>Other strange sounds may mean that you need to check and take action. For example, noises may mean that:</p> <ul style="list-style-type: none"> The cabinet is not level. The floor is uneven or weak. Bottles are badly placed and rattling. There are vibrations from an object on top of or behind or beside the refrigerator. The back of the refrigerator cabinet is touching the wall. <p>Remember it is quite normal for noise to seem louder just after the refrigerator starts operating.</p>
If there are odours inside the appliance	<ul style="list-style-type: none"> The interior may need cleaning. Some foods produce odours. Some containers and wrapping can cause odours. Ask yourself if the odour started about the same time you started storing something unusual.

When the motor seems to run more than expected	<p>Your new appliance provides you with large capacities in both the refrigerator section and the separate freezer. It is normal for the motor to operate frequently. However, to keep operation to a minimum, check the following:</p> <ul style="list-style-type: none"> Are doors kept open too long or too often? Are controls set too cold? Refer to page 7 "Controlling temperature". Have large amounts of warm food just recently been stored? Summer, festive seasons and holidays usually mean a lot more work for your appliance. If the day is hot or the room is very warm, the appliance will need to run more than normal. The appliance will run more than normal just after you install it or when it has been turned off for a long time.
If the temperature in the refrigerator is too warm	<ul style="list-style-type: none"> Check that the appliance has enough clearance at the sides, back and top. Refer to page 5 "Installing your new appliance". Refer to page 7 "Controlling temperature". You may have kept the door open too long or too frequently. Food containers or packaging may be holding a door open.
If the temperature in the refrigerator is too cold	<ul style="list-style-type: none"> Refer to page 7 "Controlling temperature". Increase the temperature to avoid high energy consumption.
If heavy frosting occurs in the freezer	<p>Make sure you fully close the freezer and fridge doors. If the doors are left partly open a heavy frost will coat the inside of the freezer. If a frost develops, remove it. Take care to properly close the doors and the frost will not reoccur.</p>
If water drips on the floor	<p>The defrost water tray, (located on the compressor at the back of the cabinet), may not be properly positioned, or the drain tube may not be properly positioned to direct water into this tray. You may need to pull the refrigerator away from the wall to check the tray and tube.</p>

If you still require service

If you have a problem, and the problem persists after you have made the checks mentioned above, contact your nearest Electrolux approved Service Centre or the dealer you bought the refrigerator from. Be ready to quote the model number, 9-digit PNC and 8-digit serial number, which is stated on the label inside the refrigerator compartment.

For more information on all Kelvinator appliances, or for dimension and installation information, call into your retailer, phone or email our customer care team or visit our website:

AUSTRALIA

phone: 1300 363 640
fax: 1800 350 067
email: customercare@electrolux.com.au
web: kelvinator.com.au

NEW ZEALAND

phone: 0800 436 245
fax: 0800 225 088
email: customercare@electrolux.co.nz
web: kelvinator.co.nz

Kelvinator. We are part of the Electrolux Family.
To add a touch of professional inspiration to your home,
visit electrolux.com.au