

MODEL  
IWC34B

WINE CHILLER  
34 BOTTLE

INALT<sup>®</sup>

CLASSIQUE

V 1.1

USER MANUAL

**Residentia Group Pty Ltd**

ACN 600 546 656

—

Head Office.

165 Barkly Avenue, Burnley

VIC Australia 3121

—

Support.

1300 11 4357

support@residentiagroup.com.au

—

Online.

residentia.group

Congratulations on purchasing your new appliance. The InAlto brand is proudly distributed within Australia by Residentia Group Pty Ltd.

Please refer to the warranty card at the rear of this manual for information regarding your product's parts and labour warranty, or visit us online at [www.residentia.group](http://www.residentia.group)

At Residentia Group, we are customer obsessed and our Support Team are there to ensure you get the most out of your appliance. Should you want to learn more about recommended temperatures, the various features of your appliance, and importantly taking care of your appliance when cleaning, our Support Team are here to help. You can use our online Support Centre at anytime by visiting <http://support.residentiagroup.com.au>, or you can contact us via calling us on 1300 11 HELP (4357).

It is important that you read through the following use and care manual thoroughly to familiarise yourself with the installation and operation requirements of your appliance to ensure optimum performance.

Again, thank you for choosing an InAlto appliance and we look forward to being of service to you.

Kind Regards,  
The Residentia Team



**A RESIDENTIA  
GROUP INITIATIVE**

# CONTENTS

<b>1 Safety warnings</b>	
1.1 Warning	1-2
1.2 Meaning of safety warning symbols	3
1.3 Electricity related warnings	3
1.4 Related warnings for use	4
1.5 Warnings related to placing items	5
1.6 Warnings for energy	5
1.7 Warnings related to disposal	5
<b>2 Proper use of wine cooler</b>	
2.1 Names of components	6
2.2 Temperature Control	7
2.3 Placement	8
2.4 Start to use	8
2.5 The arrangement of bottle	8
2.6 Practical skills for grape wine's storage	9
2.7 Serving temperature	9
2.8 Energy saving tips	9
<b>3 Maintenance of wine cooler</b>	
3.1 Disconnect the cooler	10
3.2 Stop using the cooler	10
3.3 Clean the cooler	10
<b>4 Trouble shooting</b>	11

## DEAR CUSTOMER:

Thank you for buying this wine cooler. To ensure that you get the best results from your new wine cooler, please take time to read through the simple instructions in this booklet. Please ensure that the packing material is disposed of in accordance with the current environmental requirements. When disposing of any wine cooler equipment please contact your local waste disposal department for advice on safe disposal. This appliance must be only used for its intended purpose.

## 1 Safety warnings

### 1.1 Warning



**Warning**: risk of fire / flammable materials

#### RECOMMENDATIONS:

**This** appliance is intended to be used in household and similar applications such as staff kitchen areas in shops, offices and other working environments; farm houses and by clients in hotels, motels and other residential type environments; bed and breakfast type environments; catering and similar non-retail applications.

**Children** should be supervised to ensure that they do not play with the appliance.

**If** the supply cord is damaged, it must be replaced by the manufacturer, its service agent or similarly qualified persons in order to avoid a hazard.

**Do** not store explosive substances such as aerosol cans with a flammable propellant in this appliance.

**The** appliance has to be unplugged after use and before carrying out user maintenance on the appliance.

**WARNING**: Risk of fire / flammable materials.

**WARNING**: Keep ventilation openings, in the appliance enclosure or in the built-in structure, clear of obstruction.

**WARNING**: Do not use mechanical devices or other means to accelerate the defrosting process, other than those recommended by the manufacturer.

**WARNING**: Do not damage the refrigerant circuit.

**WARNING**: Do not use electrical appliances inside the food storage compartments of the appliance, unless they are of the type recommended by the manufacturer.

**WARNING**: Please abandon the appliance according to local regulators for its use of flammable blowing gas and refrigerant.

**WARNING**: When positioning the appliance, ensure the supply cord is not trapped or damaged.

**WARNING**: Do not locate multiple portable socket-outlets or portable power supplies at the rear of the appliance.

**Do** not use extension cords or ungrounded ( two prong ) adapters.

**DANGER**: Risk of child entrapment. Before you throw away the appliance:





- Take off the doors.
- Leave the shelves in place so that children may not easily climb inside.

**The** appliance must be disconnected from the source of electrical supply before attempting the installation of accessory.

**REFRIGERANT** and cyclopentane foaming material used for the appliance are flammable. Therefore, when the appliance is scrapped, it shall be kept away from any fire source and be recovered by a special recovering company with corresponding qualification other than be disposed by combustion, so as to prevent damage to the environment or any other harm.

**FOR** EN standard: This appliance can be used by children aged from 8 years and above and persons with reduce physical sensory or mental capabilities or lack of experience and knowledge if they have been given supervision or instruction concerning use of the appliance in a safe way and understand the hazards involved. Children shall not play with the appliance. Cleaning and user maintenance shall not be made by children without supervision. Children aged from 3 to 8 years are allowed to load and unload refrigerating appliances.

**TO** avoid contamination of food, please respect the following instructions:

- Opening the door for long periods can cause a significant increase of the temperature in the compartments of the appliance.
- Clean regularly surfaces that can come in contact with food and accessible drainage systems.
- Clean water tanks if they have not been used for 48 h; flush the water system connected to a water supply if water has not been drawn for 5 days. (note 1)
- Store raw meat and fish in suitable containers in the refrigerator, so that it is not in contact with or drip onto other food.
- Two-star  frozen-food compartments are suitable for storing pre-frozen food, storing or making ice-cream and making ice cubes. (note 2)
- One  -, two  , three-star  -and four-star  compartments are not suitable for the freezing of fresh food. (note 3)

**FOR** appliances without a 4-star compartment: this refrigerating appliance is not suitable for freezing foodstuffs. (note 4)

- If the refrigerating appliance is left empty for long periods, switch off, defrost, clean, dry, and leave the door open to prevent mould developing within the appliance.

Note 1,2,3,4: Please confirm whether it is applicable according to your product compartment type.

**FOR** a freestanding appliance: this refrigerating appliance is not intended to be used as a built-in appliance.

**FOR** wine storage appliances: this appliance is intended to be used exclusively for the storage of wine.

**ANY** replacement or maintenance of the LED lamps is intended to be made by the manufacturer, its service agent or similar qualified person.

### 1.2 Meaning of safety warning symbols

	<p>The symbols indicate prohibited matters, and those behaviors are forbidden. Non-compliance with the instructions may result in product damages or endanger the personal safety of users.</p>
	<p>The symbols indicate matters that must be followed, and those behaviors must be strictly executed in line with the operation requirements. Non-compliance with the instructions may result in product damages or endanger the personal safety of users.</p>
	<p>The symbols indicate matters to pay attention to, and these behaviors shall be specially noted. Due precautions are needed or minor or moderate injuries or damages of the product will be caused.</p>

This manual contains lots of important safety information which shall be observed by the users.

### 1.3 Electricity related warnings

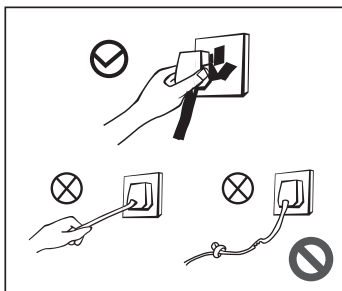

- Do not pull the power cord when pulling the power plug of the wine cooler. Please firmly grasp the plug and pull out it from the socket directly.
- Do not damage the power cord under any condition so as to ensure safety use, do not use when the power cord is damaged or the plug is worn.
- Worn or damaged power cord shall be replaced in manufacturer-authorized maintenance stations.

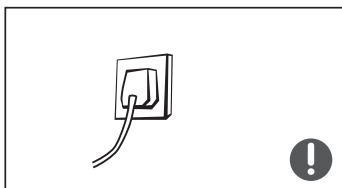

- The power cord should be firmly contacted with the socket or else fires might be caused. Please ensure that the grounding electrode of the power socket is equipped with a reliable grounding line.

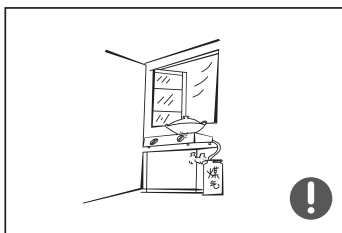

- Please turn off the valve of the leaking gas and then open the doors and windows in case of leakage of gas and other flammable gases. Do not unplug the cooler and other electrical appliances considering that spark may cause a fire.

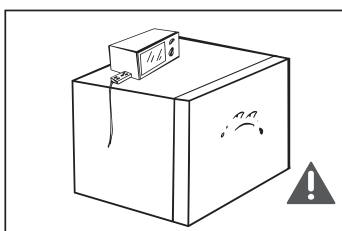

- To ensure safety, it is not recommended that to place socket, regulators, rice cookers, microwave ovens and other appliances at the top of the wine cooler, those recommended by the manufacturer are not included. Do not use electrical appliances in the food pantry.

## 1.4 Related warnings for use

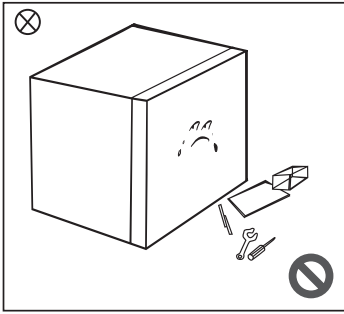

- Do not arbitrarily disassemble or reconstruct the wine cooler, nor damage the refrigerant circuit; maintenance of the appliance must be conducted by a specialist.
- Damaged power cord must be replaced by the manufacturer, its maintenance department or related professionals in order to avoid danger.

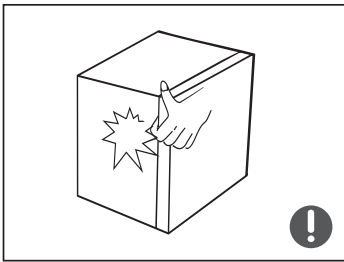

- The gaps between cooler door and cooler body are small, be noted not to put your hand in these areas to prevent from squeezing the finger. Please be gentle when close or open the cooler door to avoid falling articles.

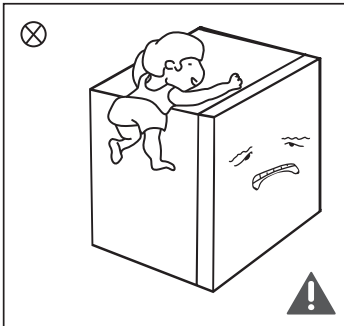

- Do not give package and other components to children to play. The bending board and plastic film may lead to suffocation! Do not allow children to enter or climb the cooler to prevent that children are sealed in the cooler or children are injured by the falling cooler.
- Do not spray or wash the cooler; do not put the cooler in moist places easy to be splashed with water so as not to affect the electrical insulation properties of the cooler.
- Do not use cooler body, cooler door, etc. as pedal or support.

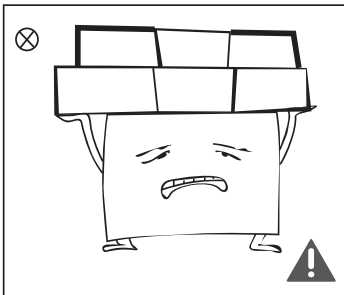

- Do not place heavy objects on the top of the cooler considering that objects may fall when open or close the door, and accidental injuries might be caused.
- Please pull out of the plug in case of power failure or cleaning. Do not connect the cooler to power supply within five minutes to prevent damages to the compressor due to successive starts.

## 1.5 Warnings related to placing items

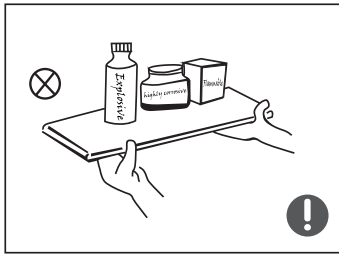

- Do not put flammable, explosive, volatile and highly corrosive items in the cooler to prevent damages to the product or fire accidents.
- Do not place flammable items near the cooler to avoid fires.

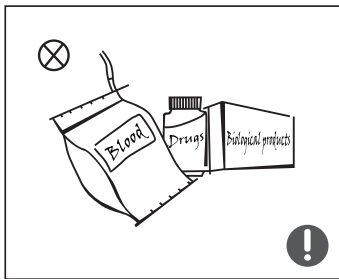



- This product is household cooler and this equipment can only be used for the storage of wine. According to the standard requirements, household cooler shall not be used for other purposes, such as storage of blood, drugs or biological products.

## 1.6 Warnings for energy

- 1) Wine cooler might not operate consistently when sited for an extended period of time below the cold end of the range of temperatures for which the cooler appliance is designed.
- 2) The need to not exceed the storage time(s) recommended by the wine manufacturers for any kind of wine.
- 3) The precautions necessary to prevent an undue rise in the temperature of the wine while defrosting the wine cooler.
- 4) The fact that a rise in temperature of the wine during manual defrosting, maintenance or cleaning could shorten the storage life.
- 5) The necessity that, for doors or lids fitted with locks and keys, the keys be kept out of the reach of children and not in the vicinity of the cooler appliance, in order to prevent children from being locking inside.

## 1.7 Warnings related to disposal

 Refrigerant and cyclopentane foaming material used for the wine cooler are flammable. Therefore, when the wine cooler is scrapped, it shall be kept away from any fire source and be recovered by a special recovering company with corresponding qualification other than be disposed by combustion, so as to prevent damage to the environment or any other harm.

 When the wine cooler is scrapped, disassemble the doors, and remove gasket of door and shelves; put the doors and shelves in a proper place, so as to prevent trapping of any child.



### Correct Disposal of this product:

This marking indicates that this product should not be disposed with other household wastes throughout the EU. To prevent possible harm to the environment or human health from uncontrolled waste disposal, recycle it responsibly to promote the sustainable reuse of material resources. To return your used device, please use the return and collection systems or contact the retailer where the product was purchased. They can take this product for environmental safe recycling.



## 2 Proper use of wine cooler

### 2.1 Names of components

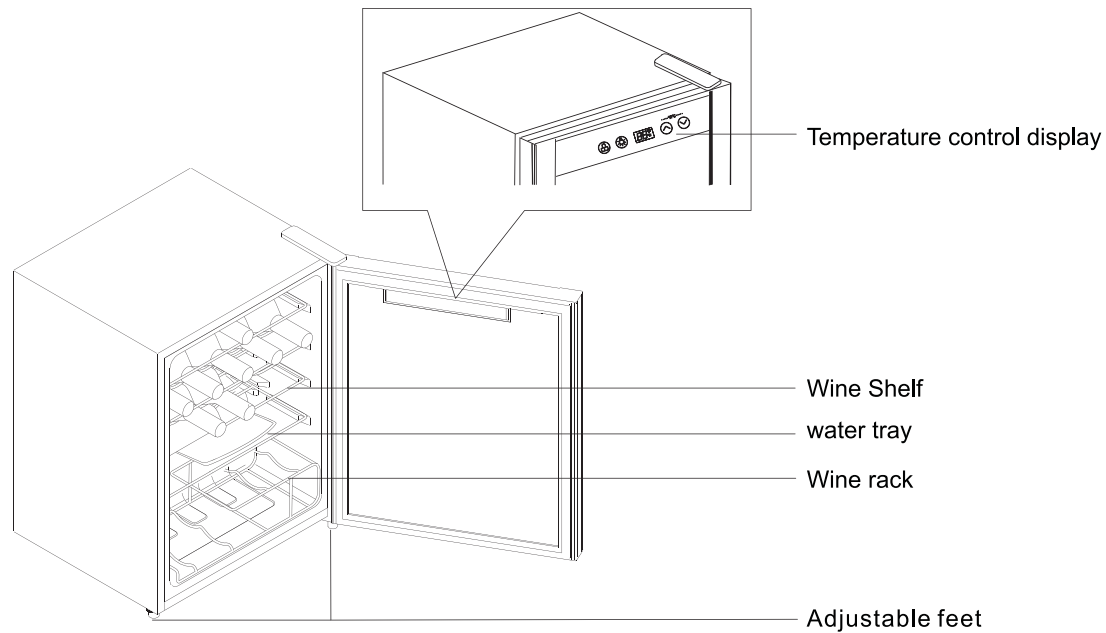

( The picture above is only for reference. The actual configuration will depend on the physical product or statement by the distributor )

- The recommended temperature is 12 °C; please keep the wine rack in the original state.
- The temperature in the wine cooler is 5-18 °C, only used to store unopened bottled wine (red wine, white wine, rose wine).
- Do not place food in the wine cooler to prevent bacterial contamination.
- Please keep the interior of the wine cabinet dry, please drink bottled wine during the validity period.

## 2.2 Temperature Control

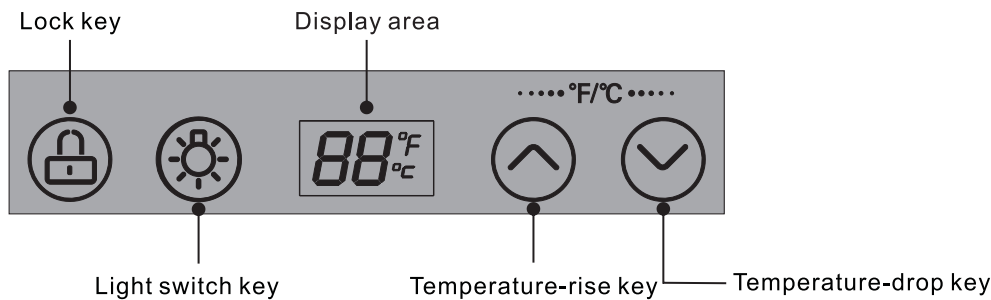

(The picture above is only for reference. The actual configuration will depend on the physical product or statement by the distributor )

### ► Display Control

when power on the wine cooler for 1st time, the display screen will display in full for 3 seconds, and the start-up tone will ring, and then enter into the display of normal running;  
When it is in the locked state, the display screen will turn off if no key operation for 30 seconds; the display screen recover the normal display if any key operation.



This cooler adopts the touch control of the glass door. Touch slightly when pressing the keys. It is to be avoided that the area of the display panel is scratched by the sharp things and it shall be kept away from the environment of high magnetic field and high humidity. Otherwise the cooler is possible not to be set and operate normally.

### ► Locking and unlocking

Under the locked state, long press the "Lock key (🔒)" continuously for 3 seconds, the locking will be relieved; the display area will blink;  
Under the unlocked state, long press the "Lock key (🔒)" continuously for 3 seconds to enter into the locked state;

Except the lighting function, the following functions will be carried out under the unlocked state.

### ► Lighting

Press the "light switch key (☀)" "to turn on or turn off the light.

### ► Switching of the Fahrenheit temperature and Celsius temperature

Press the "Temperature-rise key (⬆)" and the "Temperature-drop key (⬇)" "at same time to finish the switch of the Celsius temperature and Fahrenheit temperature; the display area will show the setting Fahrenheit temperature or Celsius temperature under the existing mode.

### ► Temperature setting

Press the "Temperature-rise key (⬆)", the temperature will increase 1°C (or °F). After locking, the cooler will run according to the setting value;  
Press the "Temperature-drop key (⬇)", the temperature will decrease 1°C (or °F). After locking, the cooler will run according to the setting value.



Setting range of the Celsius temperature: 5°C~18°C; setting range of the Fahrenheit temperature: 41 °F~65°F.

### ► Memory function

The cooler has the power off memory function. After power on again, the cooler will run according to the setting before the power-off.

### ► Fault indication

If the indication of the following table is displayed on the display area, it means the cooler is with fault.

Fault code	E1	E4
Description	Temperature sensor of the wine cooler with fault	Defrosting sensor of the wine cooler with fault



When the above faults are displayed on the screen, please do not disassemble wine cooler to check by yourself. Please contact the special maintenance personnel of the local after-sales service company for the maintenance.

### 2.3 Placement

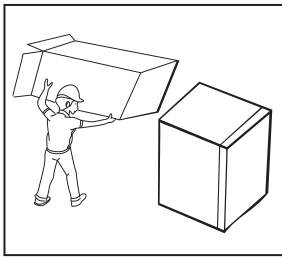

- Before using the cooler, remove all packaging materials including bottom cushions and foam pads and tapes inside the cooler, tear off the protective film on the door and the cooler body.

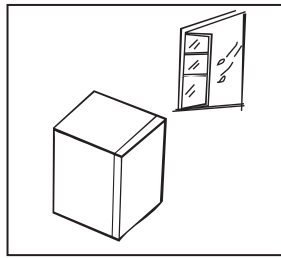

- The cooler is placed in a well-ventilated indoor place; the ground shall be flat, and sturdy (rotate left or right to adjust the wheel for levelling if unstable).

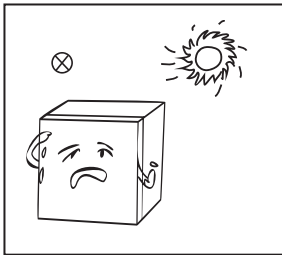

- Avoid direct sunlight and heat sources such as stove, heating radiator, etc.

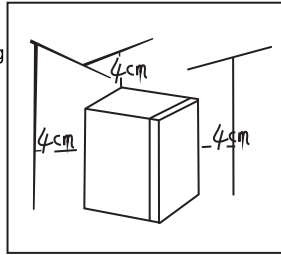

- The hot air from side wall of cooler shall be exhausted unrestricted, otherwise compressor's power will increase and further increase power consumption. Thus the distance between cooler and walls or neighboring furniture shall not be less than 4cm. It is also necessary to maintain distance for doors to open at least 90° .

### 2.4 Start to use

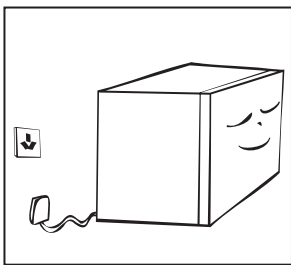

- The cooler shall stay for half an hour before connecting power when it is firstly started.
- Clean up the inner chamber before put into use for first time .
- Do not connect cooler to electronic energy saving plug and converter that can convert DC into AC (E.g.: solar energy system, ship grid).
- Water drop or frost will be generated on back side of wine cooler when compressor is running, which is decided by function of cooler. wiping out frost or water drop is not needed as the back will wipe them out automatically. The defrosted water will be collected into drain tank, then inflow into water disposal pan above the compressor and vaporized.

### 2.5 The arrangement of bottle

- Do not let bottle touch the back side of wine cooler in order to maintain good air circulation in the cooler.
- The bottle number here may be different from bottles in different shape and size.
- The capacity for bottle storage in the wine cabinet is based on the following marked bottle size. Oversized bottle may have impact on the number of bottle storage in the wine cabinet.

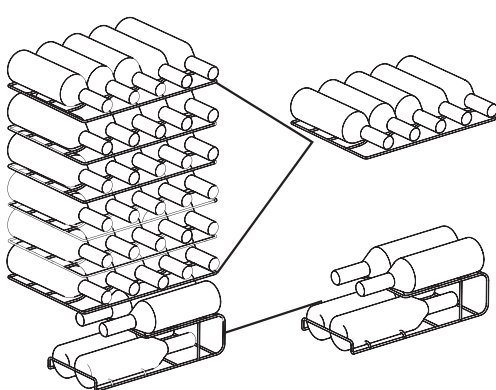
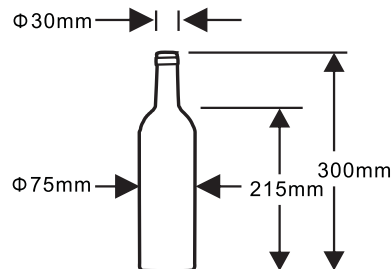

CE-JC96GE-AR

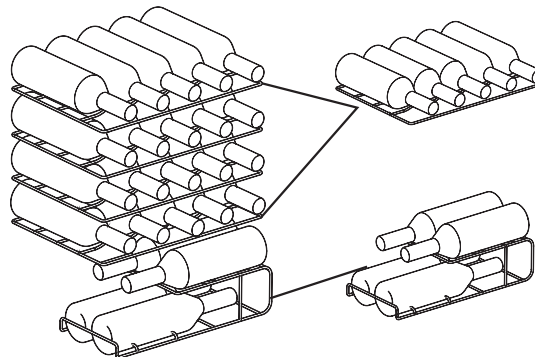

CE-JC66GE

( The picture above is only for reference. The actual configuration will depend on the physical product or statement by the distributor )

## 2.6 Practical skills for grape wine’s storage

- Do not store bottled wine by box or case in refrigerator.
- The cork of the old bottle shall always be soaked in the wine when putting into wine cooler. Air space is not allowed between wine and cork.
- Open-type bottle shelf is helpful, as it does not cut off air circulation. The air moisture that condensed on bottle can be dried out swiftly.
- The wine shall be before drinking: Such as put pink red wine onto the table 2-5 hours before drinking and red wine 4-5 hours, then can reach suitable serving temp. White wine, on the contrary, can be served right on the table. Champagne shall always be stored in cooler and taken out only before drinking.
- Please notice that wine's temperature is always lower than ideal serving temp, as the temperature will immediately rise 1 to 2°C when pouring into tumbler.

## 2.7 Serving temperature

The wine's taste depends on right pouring temperature; therefore it determines its flavor. We suggest the wine's temperature reaches the following degree when pouring:

Wine Kinds	Serving Temp
Bordeaux red	18°C
Louis Family dry red wine/Barolo	17°C
Burgundy red/Bordeaux red	16°C
Port	15°C
Young Burgundy red	14°C
Young red wine	12°C
Young Beaujolais/all white wines with little residual sugar	11°C
Old white wines/Chardonnay	10°C
Sherry	9°C
Young white wines from late vintage	8°C
White wines Loire/Entre-deux-Mers	7°C

## 2.8 Energy saving tips

- The Cooler shall be placed in room dry and ventilated. The cooler cannot be put under direct sunlight or next to heat source ( such as radiator, stove, etc. ), and a suitable insulation board shall be applied if necessary.
- Try to shorten opening time of cooler's door.

### 3 Maintenance of wine cooler

#### 3.1 Disconnect the wine cooler

Unplug power plug to disconnect the cooler.

#### 3.2 Stop using the wine cooler

If the cooler left unused for a long time, please:

1. Unplug the cooler;
2. Clean the cooler;
3. Keep the cooler door open.

#### 3.3 Clean the wine cooler

- Dusts behind the wine cooler and on the ground shall be timely cleaned to improve the cooling effect and energy saving.
- Check the door gasket regularly to make sure there are no debris. Clean the door gasket with a soft cloth dampened with soapy water or diluted detergent.
- The interior of the wine cooler should be cleaned regularly to avoid odor.
- Please turn off the power before cleaning, remove drinks, shelves, etc.
- Use a soft cloth or sponge to clean the inside of the wine cooler, with two tablespoons of baking soda and a quart of warm water. Then rinse with water and dry with a soft cloth. After cleaning, open the door and let it dry naturally before turning on the power.
- For areas that are difficult to clean in the wine cooler (such as narrow sandwiches, gaps or corners), it is recommended to wipe them regularly with a soft rag, soft brush, etc. and when necessary, combined with some auxiliary tools (such as thin sticks) to ensure no contaminants or bacteria accumulation in these areas.
- Do not use soap, detergent, scrub powder, spray cleaner, etc., as these may cause odors in the interior of the wine cooler or contaminate food.
- Clean the shelves with a soft cloth dampened with soapy water or diluted detergent. Then rinse with water and dry with a soft cloth or dry naturally.
- The wooden wine rack should not be directly immersed in liquid to prevent cracking or mold after moisture. The wooden wine rack is cleaned with a dry soft cloth. The heavily contaminated wooden wine rack should be cleaned with a soft cloth that has been wrung out, and dry naturally.
- Wipe the outer surface of the wine cooler with a soft cloth dampened with soap water, detergent, etc., and then wipe dry. Do not rub or scratch the surface of the glass door to prevent the door from being broken or scratched.
- Do not use hard brushes, clean steel balls, wire brushes, abrasives (such as toothpastes), organic solvents (such as alcohol, acetone, banana oil, etc.), boiling water, acid or alkaline items, which may damage the wine cooler surface and interior. Boiling water and organic solvents such as benzene may deform or damage plastic parts.
- Do not rinse directly with water or other liquids during cleaning to avoid short circuits or affect electrical insulation after immersion. Water should not soak the operating control elements and lighting system on the glass door.



Notice:

Do not use detergent and solvent with sand or acid.

## 4 Trouble shooting

Inoperation	<p>Whether the cooler is plugged and connected to power;                  Low voltage;                  Whether temperature control knob is in the work area;                  Failure power or tripping circuit.</p>
Long-term operation of compressor	<p>It is normal that cooler operates for longer time in summer when the ambient temperature is higher;                  Do not put too much beverage s in the cooler at one time;                  Frequent opening of cooler door.</p>
Illuminating light does not shine	<p>Whether the cooler is connected to power, whether the indicator light is damaged.</p>
Loud noises	<p>Whether the floor is flat, whether the placement of cooler is stable;                  Whether the cooler accessories are properly placed.</p>
Cooler enclosure heat Condensation	<p>The cooler enclosure may emit heat during running specially in summer, this is caused by the radiation of the condenser, and it is a normal phenomenon.                  Condensation: condensation phenomenon will be detected on the exterior surface and door seals of the cooler when the ambient humidity is high, this is a normal phenomenon, and after wiping with towel, turns up the set temperature of the appliance properly.</p>
Airflow sound Buzz Clatter	<p>Refrigerants circulating in the refrigerant lines will produce eruption of sound and grunts which is normal does not affect the cooling effect.                  Buzz will be generated by running compressor specially when starting up or shutting down.                  The solenoid valve or electric switch valve will clatter which is a normal phenomenon and does not affect the operation.</p>



# Warranty Information

---

## WARRANTY TERMS & CONDITIONS REFRIGERATION APPLIANCES

This document sets out the terms and conditions of the product warranties for Residentia Group Appliances. It is an important document. Please keep it with your proof of purchase documents in a safe place for future reference should you require service for your Appliance.

1. **IN THIS WARRANTY**
  - (a) 'acceptable quality' as referred to in clause 10 of this warranty has the same meaning referred to in the ACL;
  - (b) 'ACL' means Trade Practices Amendment (Australian Consumer Law) Act (No.2) 2010;
  - (c) 'Appliance' means any Residentia Group product purchased by you accompanied by this document;
  - (d) 'ASR' means Residentia Group authorised service representative;
  - (e) 'Residentia Group' means Residentia Group Pty Ltd of 165 Barkly Avenue, Burnley VIC 3121, ACN 600 546 656 in respect of Appliances purchased in Australia;
  - (f) 'major failure' as referred to in clause 10 of this warranty has the same meaning referred to in the ACL and includes a situation when an Appliance cannot be repaired or it is uneconomic for Residentia Group, at its discretion, to repair an Appliance during the Warranty Period;
  - (g) 'Warranty Period' means:
    - (i) where the Appliance is used for personal, domestic or household use (i.e. normal single family use) as set out in the instruction manual, the Appliance is warranted against manufacturing defects for 24 months, following the date of original purchase of the Appliance;
  - (h) 'you' means the purchaser of the Appliance not having purchased the Appliance for re-sale, and 'your' has a corresponding meaning.
2. This warranty only applies to Appliances purchased and used in Australia and is in addition to (and does not exclude, restrict, or modify in any way) any non-excludable statutory warranties in Australia.
3. During the Warranty Period Residentia Group or its ASR will, at no extra charge if your Appliance is readily accessible for service, without special equipment and subject to these terms and conditions, repair or replace any parts which it considers to be defective. Residentia Group or its ASR may use remanufactured parts to repair your Appliance. You agree that any replaced Appliances or parts become the property of Residentia Group. This warranty does not apply to light globes, batteries, filters or similar perishable parts.
4. Parts and Appliances not supplied by Residentia Group are not covered by this warranty.



- 
5. You will bear the cost of transportation, travel and delivery of the Appliance to and from Residentia Group or its ASR. If you reside outside of the service area, you will bear the cost of:
- travel of an authorised representative;
  - transportation and delivery of the Appliance to and from Residentia Group or its ASR, in all instances, unless the Appliance is transported by Residentia Group or its ASR, the Appliance is transported at the owner's cost and risk while in transit to and from Residentia Group or its ASR.
6. Proof of purchase is required before you can make a claim under this warranty.
7. You may not make a claim under this warranty unless the defect claimed is due to faulty or defective parts or workmanship. Residentia Group is not liable in the following situations (which are not exhaustive):
- the Appliance is damaged by:
    - accident
    - misuse or abuse, including failure to properly maintain or service
    - normal wear and tear
    - power surges, electrical storm damage or incorrect power supply
    - incomplete or improper installation
    - incorrect, improper or inappropriate operation
    - insect or vermin infestation
    - failure to comply with any additional instructions supplied with the Appliance;
  - the Appliance is modified without authority from Residentia Group in writing;
  - the Appliance's serial number or warranty seal has been removed or defaced;
  - the Appliance was serviced or repaired by anyone other than Residentia Group, an authorised repairer or ASR.
8. This warranty, the contract to which it relates and the relationship between you and Residentia Group are governed by the law applicable where the Appliance was purchased.
9. To the extent permitted by law, Residentia Group excludes all warranties and liabilities (other than as contained in this document) including liability for any loss or damage whether direct or indirect arising from your purchase, use or non use of the Appliance.
10. For Appliances and services provided by Residentia Group in Australia, the Appliances come with a guarantee by Residentia Group that cannot be excluded under the Australian Consumer Law. You are entitled to a replacement or refund for a major failure and for compensation for any other reasonably foreseeable loss or damage. You are also entitled to have the Appliance repaired or replaced if the Appliance fails to be of acceptable quality and the failure does not amount to a major failure. The benefits to you given by this warranty are in addition to your other rights and remedies under a law in relation to the Appliances or services to which the warranty relates.
11. At all times during the Warranty Period, Residentia Group shall, at its discretion, determine whether repair, replacement or refund will apply if an Appliance has a valid warranty claim applicable to it.
12. To enquire about claiming under this warranty, please follow these steps:
- carefully check the operating instructions, user manual and the terms of this warranty;
  - have the model and serial number of the Appliance available;
  - have the proof of purchase (e.g. an invoice) available;
  - telephone the numbers shown below.
13. You accept that if you make a warranty claim, Residentia Group and its ASR may exchange information in relation to you to enable Residentia Group to meet its obligations under this warranty.

#### IMPORTANT

Before calling for service, please ensure that the steps in point 12 have been followed.

Telephone contact

→ Service: Please call 1300 11 HELP (4357)

---

The Australian Consumer Law requires the inclusion of the following statement with this warranty:

Our goods come with guarantees that cannot be excluded under the Australian Consumer Law. You are entitled to a replacement or refund for a major failure and for compensation for any other reasonably foreseeable loss or damage. You are also entitled to have the goods repaired or replaced if the goods fail to be of acceptable quality and the failure does not amount to a major failure.





AN INITIATIVE BY

RESIDENTIA GROUP

INALTO

CLASSIQUE



E2447

TEL. 1300 11 4357

[SUPPORT@RESIDENTIAGROUP.COM.AU](mailto:SUPPORT@RESIDENTIAGROUP.COM.AU)

[WWW.RESIDENTIA.GROUP](http://WWW.RESIDENTIA.GROUP)