



CHiQ

SIDE BY SIDE REFRIGERATOR

▶ **USER MANUAL**

MODEL

CSS559NWD
CSS558NBSD
CSS557NSD



Customer Service 1300 796 688

www.chiq.com.au

PART NAMES AND LOCATIONS

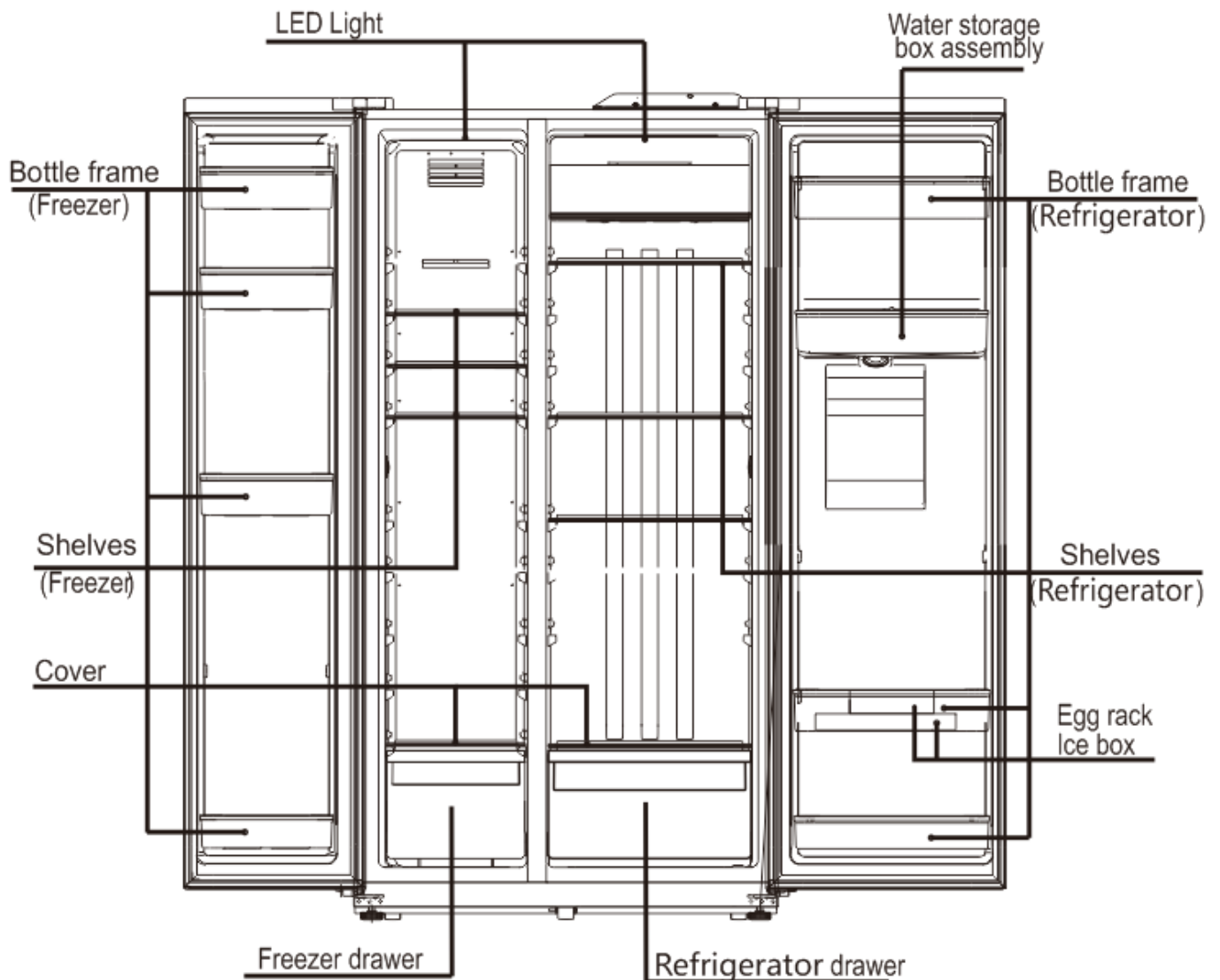

IN ACCESSORY BAG: USER MANUAL, WARRANTY CARD, EGG TRAY, ICE BOX

As the manufacturer holds the authority to redesign or modify its products without notice: Any modifications or upgrades of our products will result in this refrigerator varying slightly from this manual but the functionality will remain the same to that as set out within this manual.

IMPORTANT SAFETY INSTRUCTIONS

⚡ WARNING ⚡

Follow these basic precautions to reduce the risk of fire, electrical shock hazards or injury when operating the refrigerator:

- **This product has been designed for using in a normal domestic environment. It is not intended for commercial use which will void warranty, such as supermarket, food shop, pharmacy, commercial kitchen & etc.**
- Persons with lack of experience and knowledge, reduced physical or mental capabilities, need to be given supervision or instruction concerning use of the appliance by a person responsible for their safety.
- Children should be supervised to ensure that they do not play with the appliance. Cleaning and user maintenance shall not be made by children without supervision.
- It is critical use this appliance safely. Read all instructions before operating the refrigerator and do not attempt to repair or modify this unit in any way as it can cause harm or void the warranty.
- Please ensure all persons using this appliance are also informed and comply with the details set out within this manual and the product Terms and Conditions.
- When unpacking the appliance for the first time, keep all cardboard and plastic packaging out of reach from children.
- Report any notable defects with the appliance to Chiq or retailer as soon as it is noted. Failure to do so can result in a non-warranty claim. Keep all packaging materials in a safe location until the unit has been installed properly.
- If the supplied power cord of this unit is damaged, it must be replaced by qualify service agent or similarly qualified persons in order to avoid any risk of injury. It is recommended the power cord is situated in a safe location when operating or transporting the appliance to prevent any damage that may cause electrical shock or fire hazards.
- **DANGER or WARNING:**

Service of this unit

The installation or any service of the appliance is recommended by a qualified technician or service company.

Ventilation Hazards

Never clean the refrigerator or refrigerator parts with flammable fluids, or store gasoline or any other flammable vapors and liquids in the vicinity of this or any other refrigerator as the gas and/or vapour can cause a fire hazard, explosion or inhalation.

Electrical Connection

Make certain, when installing or moving the unit that the power outlet has been connected to, has been fitted by a qualified electrician and the ground wire has been connected properly to meet the Australian Electrical Standards.

R600a WARNINGS

NOTE: This model uses R600a flammable refrigerant in its sealed system. The following must be observed for your safety:

R600a Refrigerant Warning

- This appliance contains **0.084kg** R600a refrigerant which is environmentally friendly, but flammable. It does not damage the ozone layer, nor does it increase the greenhouse effect.
 - During transportation and installation, ensure that the tubing of the refrigerant circuit is not damaged.
 - Leaking refrigerant can ignite and may damage the eyes.
 - In the event any damage does occur, avoid exposure to open fires and any device which creates a spark. Disconnect the appliance from the mains power.
 - Thoroughly ventilate the room in which the appliance is located for several minutes.
 - Notify Customer Service for necessary action and advice.
 - The room for installing the appliance must be at least 1 cubic metre per 8 grams of refrigerant. The refrigerant quantity contained in this appliance is listed above in grams; it is also noted on the Rating Plate of the appliance.
- * Do not store explosive substances such as aerosol cans with a flammable propellant in this appliance.

It is hazardous for anyone other than an Authorised Service Person to carry out servicing or repairs to this appliance. In Queensland the authorized person must hold a Gas Work Authorisation for hydrocarbon refrigerants, before carrying out servicing or repairs which involve the removal of covers.

1. Keep ventilation openings, in the appliance enclosure or in the built-in structure, clear of obstruction.
2. Do not use mechanical devices or other means to accelerate the defrosting process, other than those recommended by the manufacturer.
3. Do not damage the refrigerant circuit.
4. Do not use electrical appliances inside the food storage compartments of the appliance, unless they are of the type recommended by the manufacturer.
5. Do not store explosive substances such as aerosol cans with a flammable propellant in the appliance.

Disposal

The environment and personal safety must be considered when disposing of this appliance. Please ensure the appliance is taken to a recycle center for safe recycling. DO NOT dispose of the appliance in land fill as the insulation and refrigerant gas contained in these appliances are flammable.

INSTALLATION INSTRUCTIONS

Before Using the Refrigerator

- Remove the exterior and interior packing.
- Before connecting the refrigerator to a power source, let the unit stand upright for approximately 4 hours to mitigate the possibility of a malfunction in the cooling system from improper handling during transportation.
- Clean the interior surface with warm water using a soft cloth.

Installing the Refrigerator

- This appliance is designed to be free standing only, and should not be recessed or built-in.
- **Allow at least 50mm of space on the back and 100mm on each side of the refrigerator to allow proper air ventilation.** Insufficient space will result in cooling and working life issue and voiding warranty.

Dimensions in mm:

W	D	H	A	B	C(°)	E	F
912	704	1770	1524	1062	160	50	100

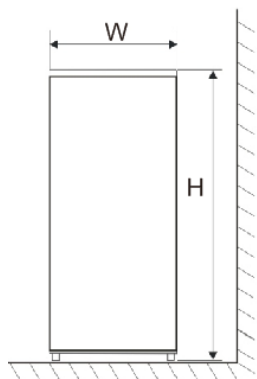

Fig. 1

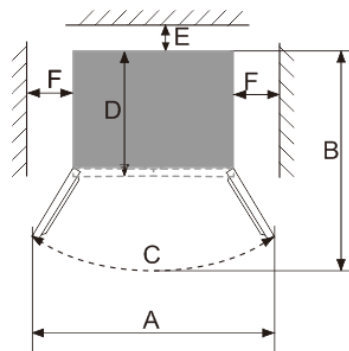

Fig. 2

- Place the refrigerator on a **leveled/even** floor surface that is strong enough to support the weight of the refrigerator when it is fully loaded to prevent vibrations.
- **Place the refrigerator on a concrete, tile floor or waterproof floor is recommended. The fridge will produce defrost water or condensation moisture, it might cause water damage in some extreme circumstances.**
- **The front feet can be adjusted to level the appliance properly.** Adjust the two front feet to keep the refrigerator leveled or elevated.
- Situate the refrigerator away from direct sunlight and sources of direct heat (stove, heater, radiator, etc.). Direct sunlight may also affect the acrylic coating and heat sources may cause an increase power consumption.
- This unit is not designed for outside installation.
- Avoid situating the refrigerator in moist OR **pest infestation** areas.
- This refrigerator appliance requires a standard 220-240VAC 50/60Hz electrical outlet with three-prong ground. Do not under any circumstances cut or remove the third

(ground) prong from the power cord. Any questions concerning power and/or grounding should be directed toward a certified electrician or an authorized service center.

- After plugging the appliance into a wall outlet, turn the unit on and allow the unit to cool down for 4-6 hours before placing food in the refrigerator.
- Do not place heavy items on the top of this appliance.

Product Features

- **Electronic control**

Adopting the electronic temperature control, the fridge-freezer is designed with a LED display screen, by which the temperature of each compartment and the working parameters can be managed and set.

- **Inverter technology**

Integrated with precise frequency conversion, noise reduction, energy saving, precise temperature control and other technologies, the fridge-freezer boasts of superior performances. Furthermore, working efficiency of the inverter compressor can be automatically adjusted according to the ambient temperature and the set temperature and keep the fridge-freezer operating in its optimal state.

- **LECO**

The fridge-freezer is internally configured with the LECO device for the net flavor and fresh-keeping purpose, with the preservation time of fruits and vegetables effectively extended.

- **Green technology**

The freon-free refrigerant and foaming insulation material are used for the fridge-freezer, causing no damage to the ozone layer and having a very small impact on the global warming, so it is the environmentally friendly product.

ENERGY SAVING TIPS

- Allow hot foods to cool to room temperature before placing in the refrigerator. Overloading the refrigerator forces the compressor to work harder. Foods that freeze too slowly may lose quality, or spoil.
- Be sure to wrap foods properly, and wipe containers dry before placing them in the refrigerator. This cuts down on frost build-up inside the refrigerator.
- Organize and label food to reduce door openings and extended searches. Remove as many items as needed at one time, and close the door as soon as possible.

OPERATING INSTRUCTIONS

Function & Setting

The display panel is on the fridge door, the following picture will show the display symbols and functions.

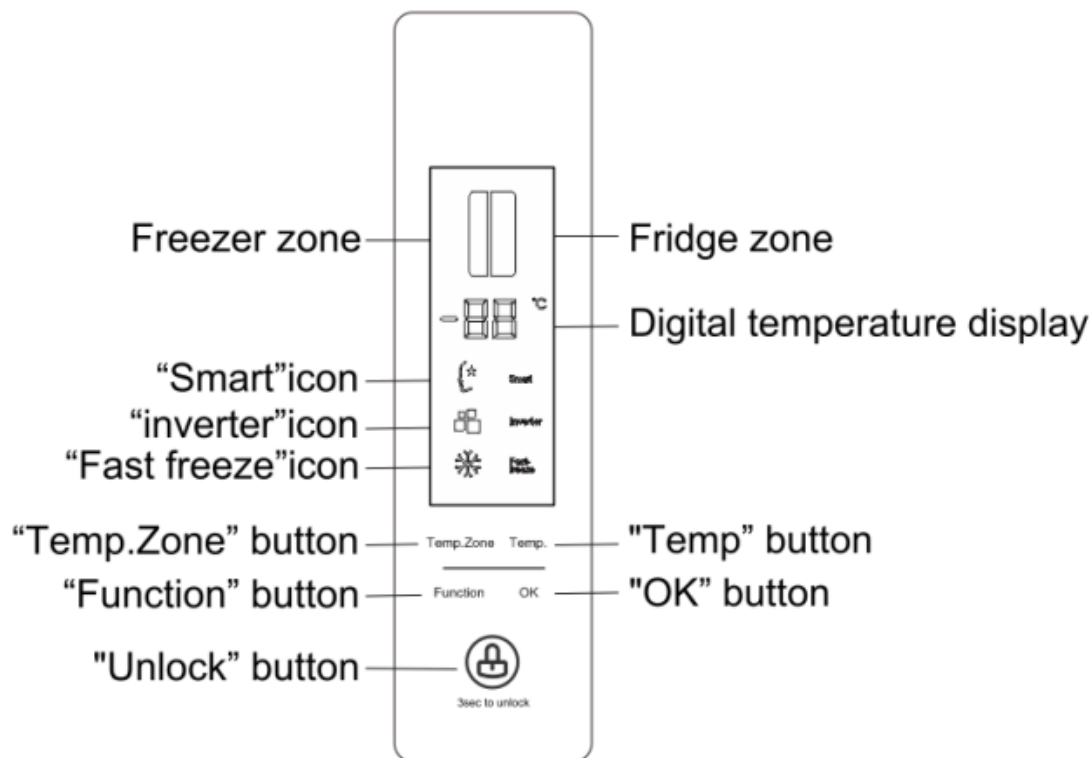

When the refrigerator system is connected to power supply for the first time, all icons on the display panel gets illuminated for 2s, and the system runs in the Smart mode by default. When all the doors are close, the display will turn off automatically if no key operation within 3 minutes. It will light up if any door is opened or any key is pressed.

The following key operations are valid only when the keys are unlocked and gets illuminated on the display.

“Inverter” is the frequency conversion indicator. It lights up when the compressor is working.

❖ Lock function

When the Child Lock function is enabled, the temperature and function can't be changed to prevent maloperation.

When press temp zone or function buttons, a beeping sound comes with no reponses on display, it means lock function is active.

- If no key operation within 3 minutes, the Child Lock function will be active automatically.
- Exit the Child Lock function manually

Press and hold the Unlock button more than 3s till a beeping sound, then the Child Lock function will be turned off.

❖ **Smart mode**

When smart mode is on, the temperature of the fridge compartment is set at 5°C, and freezer compartment at- 18°C.

Under the Smart mode, the refrigerator is running more efficiently and with better performance.

The fridge and freezer temperature setting can't be changed when smart mode is active.

Turn on Smart function

Press the Function key till the Smart symbol is flashing, then quickly press the OK key to confirm. If the OK key is not pressed within 5s, the setting won't be changed. The smart symbol will stay on when it is active properly.

Turn off Smart function

Under the Smart mode, press the Function key till the Smart symbol is flashing, then quickly press the OK key to confirm. The smart symbol will disappear when it is turned off.

❖ **Fast Freeze mode**

When the Fast Freeze function is enabled, the freezer temperature will be set at -32°C, and after 26 hours of running, the Fast Freeze function will be turned off automatically. Cooling down the freezer temperature in a rapid manner is beneficial to the prevention of food nutrition against lost and the preservation of freshness.

The fridge and freezer temperature setting can't be changed when Fast Freeze mode is active.

Turn on Fast Freeze mode

Press the Function key till the Fast Freeze is flashing, then quickly press the OK key to confirm. If the OK key is not pressed within 5s, the setting won't be changed. The Fast

Freeze symbol will stay on when it is active properly.

Turn off Fast Freeze mode

After a cumulative running period of 26 hours, the Fast Freeze function will be turned off automatically.

Or press the Function key till the Fast Freeze is flashing, then quickly press the OK key to confirm. The fast freeze symbol will disappear when it is turned off.

❖ Temperature setting

Before changing the temperature setting, please make sure the control panel isn't **locked and the smart mode and fast freeze mode** aren't active. **Temp can't be changed if any of the mode is active.**

How to check Fridge and Freezer temperature setting

Please make sure the control panel isn't **locked**, Press the **Temp. Zone** key, if fridge zone symbol (right bar) is flashing, it will show the fridge set temp. If freeze zone symbol (left bar) is flashing, it will show the freeze set temp.

Fridge compartment temperature setting

Press the **Temp. Zone** key to select the fridge zone until the fridge zone symbol (right bar) is flashing, then keep pressing the **Temp** key to set the temperature as desired and press the **OK** key or wait for 5s to validate the setting. The fridge temperature setting cycles as following: 2°C→3°C→4°C→5°C→6°C→7°C→8°C→OFF→2°C

OF indicates the fridge compartment is switched off, and when the OF function takes effect, the fridge compartment will stop cooling.

Be sure to take all food out of the fridge compartment before setting this function.

The number only shows the setting temperature which might vary to the exact temperature inside the unit.

Freezer compartment temperature setting

Press the **Temp. Zone** key to select the freezer zone until the freezer zone symbol (left bar) is flashing, then keep pressing the **Temp** key to set the temperature as desired and press the **OK** key or wait for 5s to validate the setting. The freezer temperature setting cycles as following: -18°C→-17°C→-16°C→-24°C→-23°C→-22°C→-21°C→-20°C→-19°C→-18°C

❖ **Door open alarm**

If any door is opened for more than 3 minutes, buzzer alarm will be continuously beeping. It can be stopped by pressing any key button, but will be restored after 3 minutes if the door keeps opening.

The alarm will stop when the doors are closed properly.

❖ **Power cut memory**

In the case of power failure, the refrigerator will maintain the previous setting when the power supply is restored.

❖ **Power-on delay**

In order to protect the compressor from being damaged in the case of short-time power failure (i.e., less than 5 minutes), the compressor will not be started immediately after it is powered on. But it will restart after power comes back on for more than 5 minutes.

❖ **Over-temperature alarm (only after power outage)**

When the refrigerator system is powered on, if the freezer sensor temperature is higher than -10°C , digits of the freezer zone get flickering on the display. The freezer temperature can be displayed when any key is pressed, and the normal display will be restored when any key is pressed again or after 10s.

❖ **Fault alarm**

In case E0, E1, E2, EH, or EC is displayed on the display panel, it indicates fault with the refrigerator. Please contact CHIQ service centre for a service call.

Water dispenser

The refrigerator includes a water dispenser which makes it easier to fill cold water almost immediately. To use water dispenser, follow the instructions below:

❖ **Fill the water tank**

Open the filler cover of the water tank, slowly fill the water tank to prevent any spills. Then close the filler cover of the water tank. See image C.

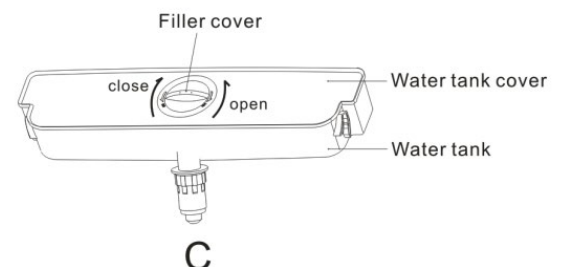

Don't remove the water tank and fill it from water tap. It is quite heavy and not easy to fit it on the correct position.

The maximum fill must be 10mm lower than the tank cover to avoid overflow and water spill.

❖ Dispense water

Depress the water switch with cup or container till reaches the required amount, then release the water switch. Don't take away the cup until no waterdrop.

When using the water dispenser, some water may drip and accumulate at the bottom of the water dispenser. Please wipe it with a cloth when necessary.

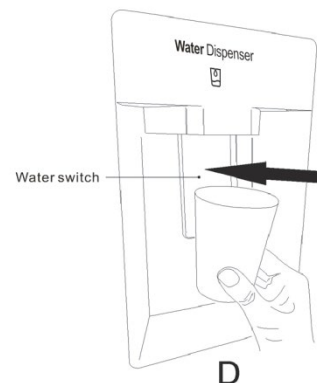

GENERAL CARE AND MAINTENANCE

Cleaning the Refrigerator

- Upon installation of your new appliance, it is recommended that it be cleaned thoroughly and properly maintained thereafter.
- Turn off the refrigerator and then unplug the unit from the wall outlet.
- Remove all food content before washing the inside with a damp cloth soaked in lukewarm water and dishwasher liquid. **Don't use any chemical detergent which might damage the fridge.**
- Be sure to keep the door gasket (seal) clean to keep the unit running efficiently as improper cleaning can cause the seal to dislodge and tear.
- Dry the interior and exterior with a soft cloth.

Vacation Time

- Turn off the refrigerator first and then unplug the unit from the power point.
- Remove all food.
- Clean the refrigerator.
- Leave the lid open slightly to avoid possible formation of condensation, mold, or odors.
- Use extreme caution in the case of children. The unit should not be accessible to child's play.
- **Short vacations:** Leave the refrigerator operating during vacations of less than three weeks.
- **Long vacations:** If the appliance will not be used for several months, remove all food and unplug the power cord. Clean and dry the interior thoroughly. To prevent odour and mold growth, leave the door open slightly: blocking it open if necessary.

Repositioning and Relocating the Refrigerator

- Unplug the power cord from the wall outlet.
- Remove all the food and drinks.
- Securely tape down all loose items inside your refrigerator.
- Tape the doors to be closed securely.
- It is recommended that the refrigerator stays in the upright position during transportation. But if it is laid down for transport purpose, please lift it up immediately after the job is done. Please wait for at least 24 hours before putting the power.

TROUBLESHOOTING GUIDE

Problem	Solution
The fridge has no power	<ul style="list-style-type: none"> ➤ Power cord isn't plugged in properly. ➤ The circuit breaker tripped or a blown fuse. ➤ Try a different power point.
The light is not working.	<ul style="list-style-type: none"> ➤ There is no light in freezer compartment, only fridge compartment has light. ➤ Make sure the power is connected to the unit.
Compressor runs all the time	<ul style="list-style-type: none"> ➤ The room temperature is hotter than normal. ➤ A large amount of food has been added to the refrigerator. ➤ The door is opened too often. ➤ The door is not closed completely. ➤ The temperature control is not set correctly. ➤ The door gasket does not seal properly. ➤ The refrigerator does not have the correct clearances. ➤ The refrigerator has recently been disconnected for a period of time. 6+ hours are required for the refrigerator to cool down completely pending on operating conditions.
Temperature inside the refrigerator is too warm.	<ul style="list-style-type: none"> ➤ Temperature control is set incorrectly. Turn the control to a cooler setting and allow several hours for the temperature to stabilize. ➤ Door is kept open too long or is opened too frequently. Warm air enters the refrigerator every time the door is opened). Open the door less often. ➤ The door is not closed completely. ➤ The door gasket does not seal properly.

<p>Temperature inside the refrigerator is too cold.</p>	<ul style="list-style-type: none"> ➤ Temperature control is set too cold. Turn the control to a warmer setting and allow several hours for the temperature to stabilize.
<p>Temperature of external refrigerator side walls are warm.</p>	<ul style="list-style-type: none"> ➤ The exterior refrigerator walls can be as much as 15-20 degrees warmer than room temperature. This is normal while the compressor works to transfer heat from inside the refrigerator cabinet to the condenser behind the refrigerator side walls.
<p>Popping or cracking sound when compressor comes on.</p>	<ul style="list-style-type: none"> ➤ Metal parts undergo expansion and contraction, as in hot water pipes. This is normal. Sound will level off or disappear as refrigerator continues to run.
<p>Bubbling or gurgling sound, like water boiling.</p>	<ul style="list-style-type: none"> ➤ Refrigerant (used to cool refrigerator) is circulating throughout the system. This is normal operation.
<p>Vibrations.</p>	<ul style="list-style-type: none"> ➤ Check the refrigerator is on a level/even surface. ➤ Refrigerator rocks on the floor when it is moved slightly. Be sure floor can adequately support refrigerator. ➤ Level the refrigerator by putting wood or metal shims under part of the refrigerator. ➤ The refrigerator is touching the wall. Re-level the refrigerator and move it from the wall. See “Installation Instructions”.
<p>Moisture forms on inside refrigerator walls.</p>	<ul style="list-style-type: none"> ➤ Weather is hot and humid, which increases internal rate of frost build-up. This is normal. ➤ Door is slightly open. ➤ Door is kept open too long, or is opened too frequently. Open the door less often. ➤ The door is not sealed properly.
<p>Moisture forms on outside of refrigerator.</p>	<ul style="list-style-type: none"> ➤ Door is slightly open, causing cold air from inside the refrigerator to meet warm moist air from the outside.
<p>The doors will not close properly.</p>	<ul style="list-style-type: none"> ➤ The refrigerator is not on a level surface. ➤ The gasket/s may be dirty or not properly maintained. Clean the seals and make sure they are dry before closing the door/s. ➤ The storage basket and/or shelves are out of position.

For any enquiries, please call the CHiQ Customer care on: 1300 796 688



Customer Service

1300 796 688

www.chiq.com.au