

AMO31X

built-in or freestanding microwave oven



- SIZE mm** 520W x 430Dx300H
- FINISH** stainless steel exterior and interior
- CAPACITY** 31 litres
- FEATURES**
- Easi-tronic operation
 - push-button door
 - power output 900W
 - 315mm tempered glass turntable
 - 6 auto cook menus
 - 5 power settings
 - end-cooking signal
 - child safety lock
 - LED display

OPTION AMO31TK stainless steel trimkit for integration above oven

POWER total electrical consumption: 0.9 kW/hr
10 Amp GPO, 3-pin plug and cord

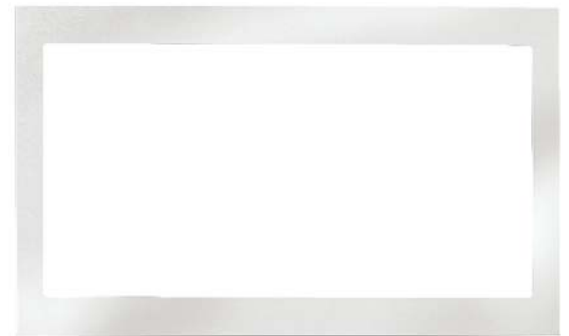

EAN 9347777000699

DISCLAIMER

Eurolinx PTY LTD is continually seeking ways to improve the design specifications, aesthetics and production techniques of its products. As a result alterations to our products and designs take place continually. Whilst every effort is made to produce information and literature that is up to date, this brochure should not be regarded as an infallible guide to the current specifications, nor does it constitute an offer for the sale of any particular product. Product dimensions indicated in our literature is indicative only. Actual product only should be used to define dimension cutouts. Distributors, and retailers are not agents of Eurolinx and are not authorized to bind Eurolinx by any express or implied undertaking or representation.

AR281215

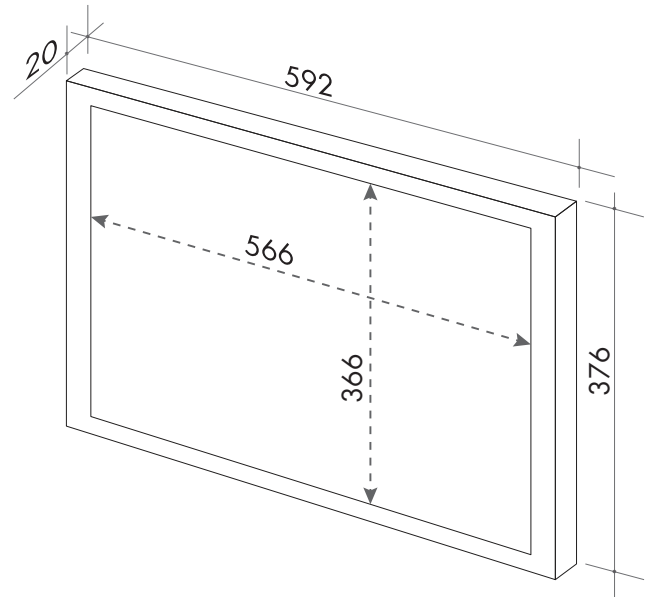
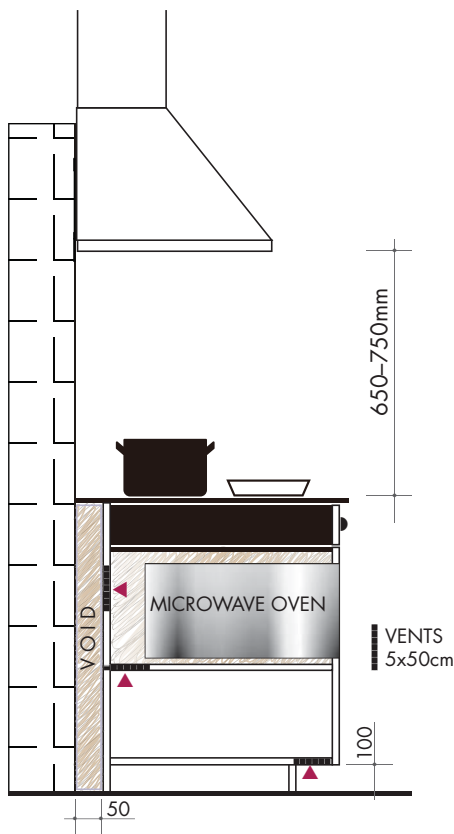
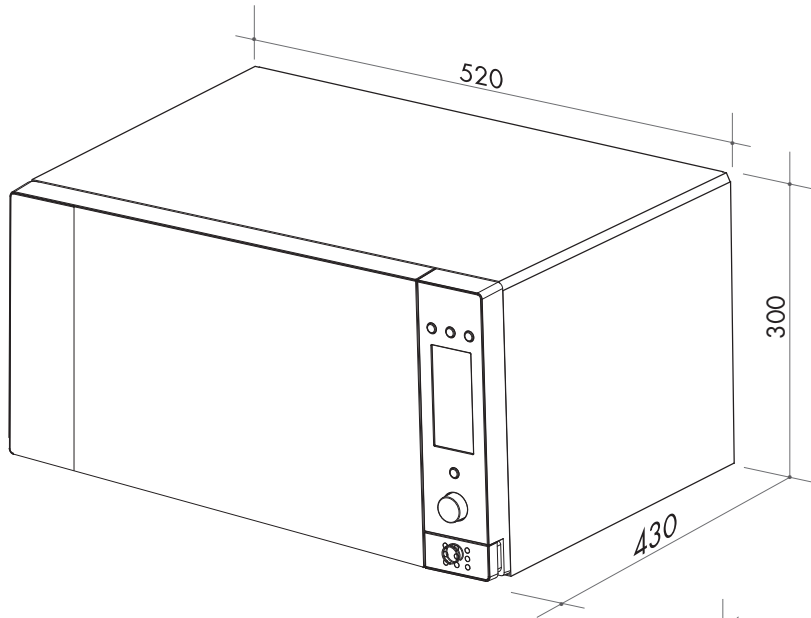

VENTILATION REQUIREMENTS
FOR UNDERBENCH INSTALLATION

NB: drawings are not to scale — they are to be used. For detailed installation instructions, please refer to user guide.

Australia National Telephone Number 1300 694 583 New Zealand Telephone Number 0508 458 369
ARTUSI showrooms are open daily from 9am-5pm and Saturdays 10am-4pm

artusi.com.au

NSW & ACT
(head office)

48 Moore Street
Leichhardt
02 8569 4699

VIC | SA

1211 Toorak Road
CAMBERWELL
03 9809 2155

TASMANIA

3 Pear Avenue
DERWENT PARK 7009
03 6272 7386

QLD

1/42 Cavendish Road
COORPAROO
07 3397 0850

WA | NT

10/55 Howe Street
OSBORNE PARK
08 9201 9188

New Zealand

PO Box 11.160
Sockburn Christchurch
03 344 5913