

AMO31TK

microwave oven with integrated trimkit



<b>SIZE mm</b>	592W x 430D + 20mm fascia x 390H
<b>FINISH</b>	stainless steel exterior and interior
<b>CAPACITY</b>	31 litres
<b>FEATURES</b>	<ul style="list-style-type: none"> <li>• Easi-tronic operation</li> <li>• push-button door</li> <li>• power output 900W</li> <li>• grill 1200W</li> <li>• 2 grill levels</li> <li>• 315mm tempered glass turntable</li> <li>• 6 auto cook menus</li> <li>• 5 power settings</li> <li>• end-cooking signal</li> <li>• child safety lock</li> <li>• LED display</li> </ul>
<b>POWER</b>	220-240V, 50/60 Hz rated input: 1.45 kWh rated microwave output: 0.9 kW/hr microwave frequency: 2450 MHz 10 Amp GPO, 3-pin plug and cord



EAN 9347777000712

**DISCLAIMER**

Eurolinx PTY LTD is continually seeking ways to improve the design specifications, aesthetics and production techniques of its products. As a result alterations to our products and designs take place continually. Whilst every effort is made to produce information and literature that is up to date, this brochure should not be regarded as an infallible guide to the current specifications, nor does it constitute an offer for the sale of any particular product. Product dimensions indicated in our literature is indicative only. Actual product only should be used to define dimension cutouts. Distributors, and retailers are not agents of Eurolinx and are not authorized to bind Eurolinx by any express or implied undertaking or representation.

AR281215

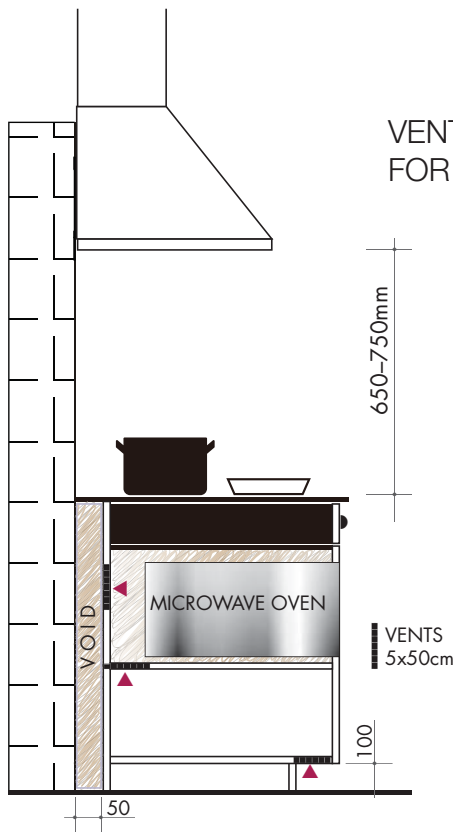
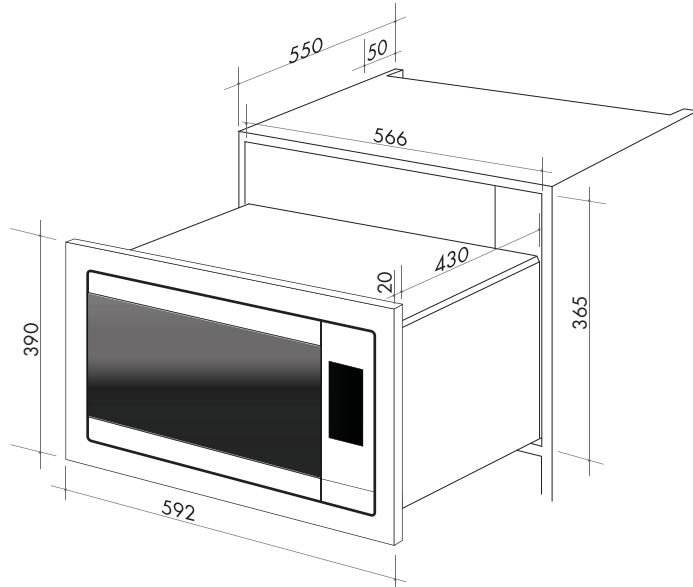

VENTILATION REQUIREMENTS  
FOR UNDERBENCH INSTALLATION

NB: drawings are not to scale — they are to be used. For detailed installation instructions, please refer to user guide.