

# AOF6SE1 OVEN 600MM



## Features

- 5 Multifunction: Fan Forced, Fan Grill, Grill, Defrost, Light
- 56 litre net capacity; 60 litre gross
- “A” Class energy efficiency
- Triple-glazed door
- Cooling Fan
- 120 minute minder
- 5 shelf levels
- Oven light

## Accessories included:

- 2 chrome oven shelves
- 1 universal baking pan
- 1 grill insert

Total Power: 2.56kW (10.6 amp connection)

Power: 220 - 240 volt/50Hz

## Product Dimensions:

594mm (H) x 594mm (W) x 566mm\* (D) \*(incl. 21mm front frame)

## Cutout Dimensions:

575mm (H) X 565mm (W) X 550mm (D)  
 diagram below refers to flush mounting installation

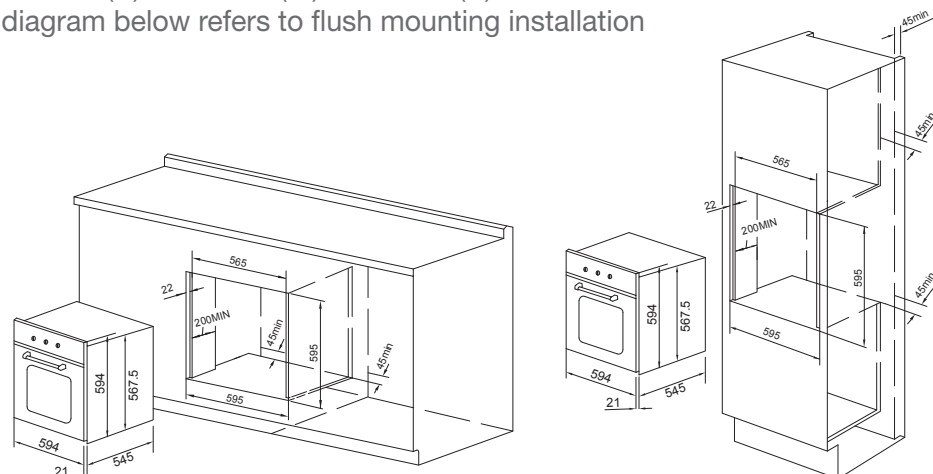

warranty - customer service

### Warranty

2 years Parts and Labour

### Customer Service

Our Nationwide Service Team can be contacted on our Toll Free Customer Service Number 1800 805 300 or by logging on to <http://customersupport.hapl.com.au/>

## HOME APPLIANCES

20 Carlotta Street  
 Artarmon NSW 2064  
 T: 02 9958 3111  
 F: 02 9958 3555  
 E: [info@hapl.com.au](mailto:info@hapl.com.au)

[www.arcappliances.com.au](http://www.arcappliances.com.au)