

MODEL AUM60



60CM CONCEALED UNDERMOUNT RANGEHOOD



24 MONTH WARRANTY



60CM



LED LIGHTS



PUSH BUTTON



10AMP POWER CONNECTION

PRODUCT INFORMATION

FEATURES

- Stainless steel
- aluminium filters
- carbon filter included
- 3 speeds
- push-button control
- 750m³/hr airflow
- 2 x 1.5W LED lights
- 39.5 dBA (power level 1)
- Ø150mm ducting

This unit comes standard with a charcoal filter mesh integrated with the aluminium filters for use in installations where it is used in recirculating mode. If the unit is installed in ducted mode the black charcoal foam sheet should be removed from the filter. The charcoal filters cannot be cleaned or recycled and must be replaced etc. Replacements are available from spares@eurolinx.com.au.

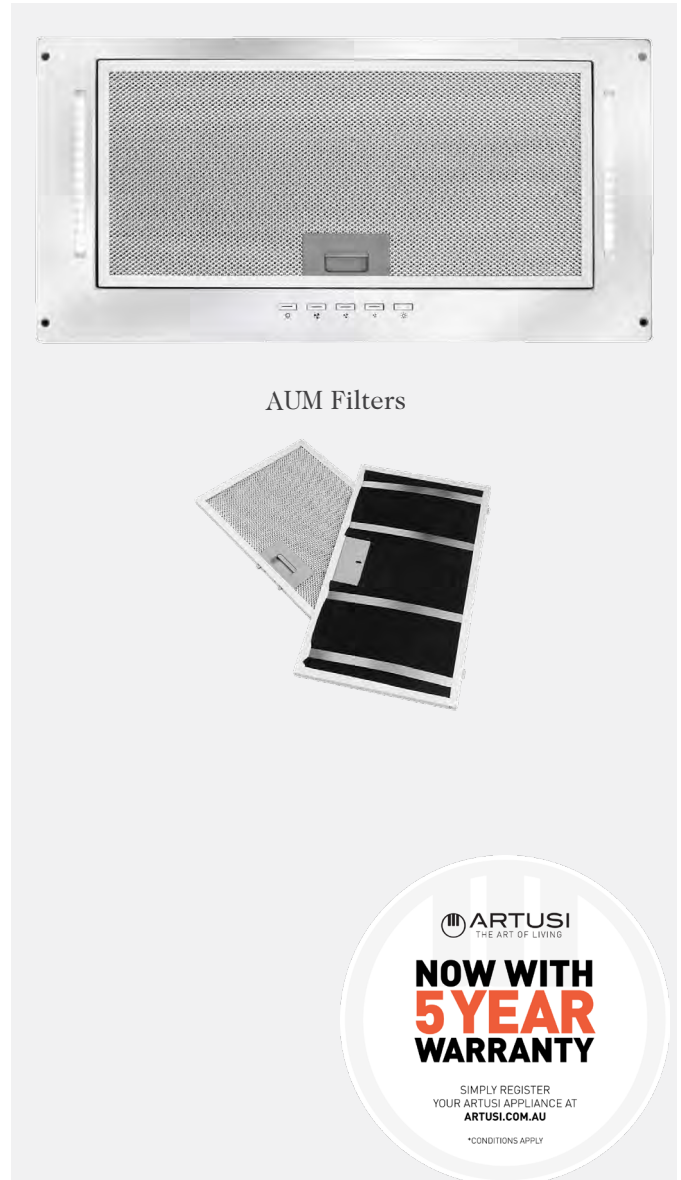

AUM Filters

EAN 9347777000477

AR21102020

DISCLAIMER

Eurolinx PTY LTD, is continually seeking ways to improve the design specifications, aesthetics and production techniques of its products. As a result alterations to our products and designs take place continually. Whilst every effort is made to produce information and literature that is up to date, this brochure should not be regarded as an infallible guide to the current specifications, nor does it constitute an offer for the sale of any particular product. Product dimensions indicated in our literature is indicative only. Actual product only should be used to define dimension cut outs. Distributors, and retailers are not agents of Eurolinx and are not authorized to bind Eurolinx by any express or implied undertaking or representation.

FOLLOW US ON: [instagram.com/artusi_appliances](https://www.instagram.com/artusi_appliances)

www.linkedin.com/company/eurolinx-pty-ltd-t-a-llve/

Australia National Telephone Number 1300 (694 583) New Zealand Telephone Number 64 3 344 5913
 Artusi showroom hours: Tuesday to Friday - 9am-5pm, Saturday - 10am-4pm, Sunday and Monday - closed
 * Melbourne showroom hours: Tuesday to Saturday - 10am-4pm

artusi.com.au

NSW & ACT (Head Office)
 48-50 Moore Street
 Leichhardt
 F 02 8569 4699

QLD
 1/42 Cavendish Road
 Coorparoo
 F 07 3397 0850

WA & NT
 Unit 10/55 Howe Street
 Osborne Park
 F 08 9201 9188

New Zealand
 PO Box 11,160
 Sockburn Christchurch
 F 03 344 5906

MODEL AUM60



60CM CONCEALED UNDERMOUNT RANGEHOOD



24 MONTH WARRANTY



60CM



LED LIGHTS



PUSH BUTTON



10AMP POWER CONNECTION

TECHNICAL DIAGRAM

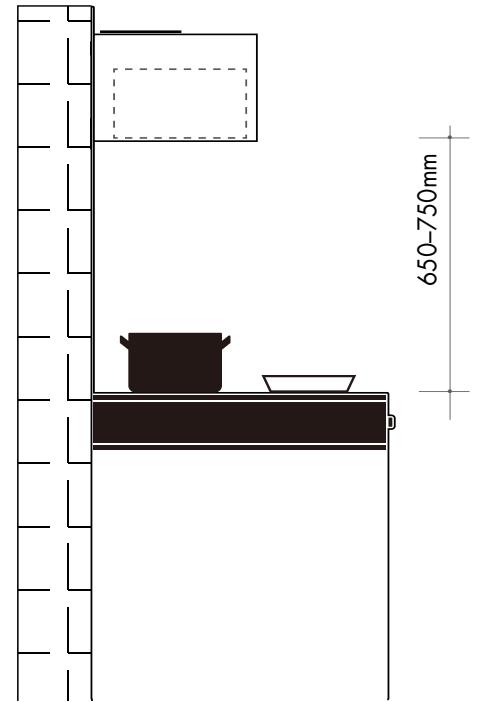
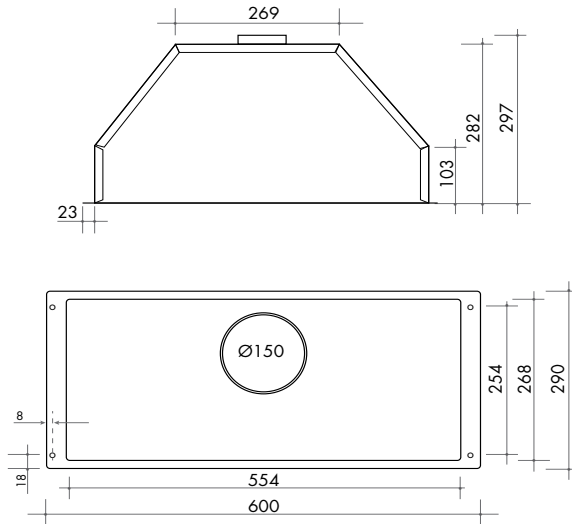

	AIRFLOW (m ³ /hr)	NOISE (dB)	PRESSURE (Pa)	POWER OUTLET (W)
LOW	580	54.8	411	167
MEDIUM	680	58.5	447	200
HIGH	784	61.2	468	228

NB: drawings are not to scale — they are to be used for detailed installation instructions, please refer to user guide.

EAN 9347777000477

AR21102020

DISCLAIMER

Eurolinx PTY LTD, is continually seeking ways to improve the design specifications, aesthetics and production techniques of its products. As a result alterations to our products and designs take place continually. Whilst every effort is made to produce information and literature that is up to date, this brochure should not be regarded as an infallible guide to the current specifications, nor does it constitute an offer for the sale of any particular product. Product dimensions indicated in our literature is indicative only. Actual product only should be used to define dimension cut outs. Distributors, and retailers are not agents of Eurolinx and are not authorized to bind Eurolinx by any express or implied undertaking or representation.

AUM60 60cm concealed undermount rangehood
10 AMP electrical connection, 3-pin plug and cord
150W motor

FOLLOW US ON: [instagram.com/artusi_appliances](https://www.instagram.com/artusi_appliances)

www.linkedin.com/company/eurolinx-pty-ltd-t-a-lve/

Australia National Telephone Number 1300 (694 583) New Zealand Telephone Number 64 3 344 5913
Artusi showroom hours: Tuesday to Friday - 9am-5pm, Saturday - 10am-4pm, Sunday and Monday - closed
* Melbourne showroom hours: Tuesday to Saturday - 10am-4pm

[artusi.com.au](https://www.artusi.com.au)

NSW & ACT (Head Office)
48-50 Moore Street
Leichhardt
F 02 8569 4699

QLD
1/42 Cavendish Road
Coorparoo
F 07 3397 0850

WA & NT
Unit 10/55 Howe Street
Osborne Park
F 08 9201 9188

New Zealand
PO Box 11,160
Sockburn Christchurch
F 03 344 5906