

AKAI

HOME



8kg Front Load Washing Machine with Wi-Fi Function

INSTRUCTION MANUAL

MODEL: AK-FL8S



Contents

- 03 General Safety Instructions**
- 07 Unpacking**
- 08 Product Overview**
- 10 Installation**
- 16 Instructions**
- 24 Wi-Fi Control**
- 28 FAQs and Troubleshooting Guide**
- 30 Other Useful Information**

General Safety Instructions

IMPORTANT SAFETY INSTRUCTIONS READ CAREFULLY AND KEEP FOR FUTURE REFERENCE

Read this manual thoroughly before first use, even if you are familiar with this type of product. The safety precautions enclosed herein reduce the risk of fire, electric shock and injury when correctly adhered to. Keep the manual in a safe place for future reference, along with any warranty information and your purchase receipt. If applicable, pass these instructions on to the next owner of the appliance. **Always follow basic safety precautions and accident prevention measures when using an electrical appliance, including the following:**

Pay particular attention to safety advice following the words:

DANGER, WARNING and CAUTION.

These words are used to alert you to a potential hazard that can seriously injure you and others. The instructions will tell you how to reduce the chance of injury and let you know what can happen if the instructions are not followed.

DANGER means that failure to read this safety statement may result in severe personal injury or death.

WARNING means that failure to read this safety statement may result in extensive product damage or serious personal injury.

CAUTION means that failure to read this safety statement may result in minor or moderate personal injury, property or equipment damage.

Electrical safety and cord handling

- **Voltage:** Before connecting and turning on the appliance, ensure the electrical voltage and circuit frequency correspond to those indicated on the appliance rating label.
- **Power supply system:** Make sure the power supply system (current, power voltage and wire) at your home can meet the normal loading requirements of electrical appliances.
- **WARNING!** Only connect the washing machine to a grounded (earthed) electrical outlet. Do not overload the wall outlet, as overloading can result in fire or electric shock. Insert the power plug securely.
- **Protect from moisture:** To avoid electric shock, fire and malfunction, do not install this machine in a damp place. Do not pull out or insert the plug with wet hands or bare feet. Do not expose the appliance, cord or plug to rain, moisture or other liquid.
- **Power cord:** Do not kink or damage the power cord, and position it out of the way so no one steps on or places anything on the cord or against it.

WARNING! Do not use the machine if the cord or plug is damaged to avoid an electric shock, short circuit or fire. If the cord is damaged, it must be replaced by the manufacturer's service agent or a properly qualified person in order to avoid a hazard.

General Safety Instructions (Cont.)

- **CAUTION!** Do not connect the appliance to the power supply using a power adaptor or extension cord. Use of an extension cord does not guarantee the required safety.
- **After use:** Always unplug the appliance and turn off the water after use.
- **Disconnect:** Unplug the washing machine from the power supply before cleaning, servicing, maintenance or moving the appliance. Pull by the plug, not by the cord.
- **Keep openings clear:** Do not insert any objects into ventilation or similar openings.
- **No timer:** The appliance is not intended to be operated by means of an external timer or separate remote control system.
- **RCD:** Unless your home is already fitted with a residual current device (safety switch), we recommend installing an RCD with a rated residual operating current not exceeding 30mA to provide additional safety protection when using electrical appliances. See your electrician for professional advice.

Installation

- **WARNING! This appliance is extremely heavy. Transport with care!** A team lift or mechanical aid is required when moving the machine. Do not hold the washing machine by the door or any other protruding part while lifting or transporting it.
- **Freestanding use only:** This appliance is not to be built in.
- **Do NOT install the appliance:**
 - outdoors or in a damp or wet environment (such as a bathroom)
 - in areas where caustic or explosive gases are present
 - near open flames or heat sources
 - behind a lockable door, a sliding door or a door with a hinge on the opposite side to that of the washer in such a way that a full opening of the washer door is restricted.
- **Installation surface:** This washing machine must be installed on a flat, even and stable ground to avoid overturning during use or maintenance. Do not place it on carpet. If the machine must be positioned on carpet, place a plastic mat underneath the machine and make sure any ventilation openings in the base are not obstructed.
- **Clearances:** Ensure that there is a distance of at least 200mm between the appliance and any external heat sources, such as appliances containing heating elements.
- **Installation:** Make sure that all water and electrical connections are made by qualified persons only, observing local safety regulations and following the installation instructions in this manual (refer to “Installation”, pages 10–15). Do not use the appliance until it is fully installed.
- **Water connection:** This machine has only one inlet for water (cold). Do not connect it to the hot water supply. Connect the machine to the water mains using new hose sets. Do not reuse old hose sets. The required water pressure is 0.02MPa (min.) to 0.8MPa (max.)
- **Drainage:** Do not allow the water drained out of the appliance to accumulate.
- **Ventilation openings:** Do not cover any air inlet or exhaust openings.

General Safety Instructions (Cont.)

- **Electrical connection:** During installation, the power cord must not be excessively or dangerously bent or flattened. The plug must be accessible after installation.
- **Misuse:** Improper installation or faulty use may result in the risk of fire, electric shock and/or injury. We accept no liability for any eventual damages or injury caused by improper installation, misuse or noncompliance with these instructions.

Usage conditions and restrictions

- **Domestic use only:** This appliance is intended for indoor domestic use only, which includes use in households, staff kitchen areas in shops, offices, in farm houses and in other working environments, use by clients in hotels, motels, bed and breakfast establishments, and in areas for communal use in blocks of flats and other residential type environments. It is NOT suitable for commercial or industrial use.
- **Intended purpose:** This washing machine is designed for washing domestic quantities of textiles suitable for machine-washing. Do not use the machine for anything other than its intended purpose, and only use it as described in this manual.
- **No outdoor use:** Do not operate the appliance outdoors.
- **Usage restriction:** This appliance is not intended for use by persons (including children) with reduced physical, sensory or mental capabilities, or lack of experience and knowledge, unless they have been given supervision or instruction concerning use of the appliance by a person responsible for their safety.
- **Children:** Supervise children to ensure they do not play with the appliance. Close supervision is necessary when any appliance is used by or near children. Do not allow children (or anyone else) to climb up and sit on top of the washing machine.
- **Handling:** Handle the washing machine with care. Do not place or store flammable items or heavy objects on top of the machine. Do not sit on the top cover.
- **Door handling:** Handle the door with care. Do not lean against the machine door. Do not let children swing from the door. Do not close the door with excessive force. If you find it difficult to close the door, please check and ensure that the clothes are properly loaded and well distributed.
- **Before loading the washing machine, make sure that:**
 - no young child or pet has climbed into the drum
 - the water inlet hose is properly connected and the tap is turned on
 - all pockets of clothing to be washed are empty. Hard, sharp objects such as coins, safety pins, paper clips, bra wires, nails, screws or stones can cause extensive damage to the appliance and block the pump. Any damage or malfunction resulting from foreign objects is not covered by your warranty and may lead to expensive repairs.
- **Do NOT wash the following items in the washing machine:**
 - rain jackets, raincoats, fishing coats and similar waterproof clothes or covers
 - carpets or floor rugs
 - underwire bras (damage to the appliance can result if metal reinforcements come loose during the washing cycle).

General Safety Instructions (Cont.)

- Clothes that have any residues of flammable materials, as this may result in fire or explosion. For example, articles that have been cleaned in, washed in, soaked in, or dabbed with industrial chemicals, or combustible or explosive substances (such as wax, oil, paint, petrol, alcohol, degreasers, dry-cleaning solvents, kerosene, etc.). Items containing such substances must be washed by hand or rinsed thoroughly before they may be machine-washed.
- **Flammable, explosive or toxic substances must not be used** as washing detergents or for cleaning the machine.
- **Capacity:** Do not overload the washer; its maximum capacity is 8kg (max. weight of dry wash load).
- **Water intake:** Never refill the water by hand during washing.
- **After use:** After the program is finished, wait until the drum has stopped spinning and the door lock icon is no longer lit before opening the door. If water is still visible, do not attempt to open the door. Do not add or remove clothes while the drum is spinning.
- **Disconnect** the water and power supplies after use.

CAUTION: Hot!

- During a hot wash, the door window may become hot. Do not touch it, and ensure to keep children and pets away from the machine during operation.
- Be careful of burning when the machine drains hot washing water.

Cleaning and maintenance

- **Disconnect:** Before cleaning or carrying out maintenance, always unplug the appliance from the power supply.
- **CAUTION!** After each wash, clean the door and the door seals and remove any threads, lint or foreign objects. Also check the detergent drawer and clean out detergent residues. Regularly clean the power plug to remove dust and dirt and avoid contact failure. Cleaning and user maintenance shall not be carried out by children without supervision. Do not spray the machine with water.
- **CAUTION!** Cleaning the inside of your washing machine regularly is particularly important **if you frequently use a cold wash cycle**, especially if you also use a fabric softener. Liquid detergents can cause detergent scum to build up around the outside of the drum, which cold water will not remove and which can cause bacteria, unpleasant odours, and eventually soiling of your wash load.
- **Do not open the housing:** The washing machine has no user-serviceable parts contained within. Do not attempt to repair, dismantle or modify it.
- **Service:** Only have the appliance serviced by authorised service personnel. Service or repairs carried out by inexperienced or unqualified persons may cause injury and/or make more serious repairs to the appliance necessary.

Unpacking

Unpacking the washing machine

CAUTION: EXTREMELY HEAVY!

- A team lift or mechanical aid is required when moving this appliance.
- Keep the washing machine as upright as possible during transportation.

- This product has been packaged to protect it against transportation damage. Remove all packaging materials from around the appliance and inside the drum, including the foam base (Fig. 1).
- Keep the original packaging carton and materials in a safe place. It will help prevent any damage if the product needs to be transported in the future, and you can use it to store the appliance when it is not in use. In the event that the carton is to be disposed of, please recycle all packaging materials where possible.
- Plastic wrapping can be a suffocation hazard for babies and young children, so ensure all packaging materials are out of their reach and disposed of safely.
- Remove any tapes securing the power supply cord and drain hose and all accessory parts from the drum.
- If you notice any water drops on the packaging bags or the door glass, do not be alarmed. This is normal as the appliance is fully checked in the factory before it is being packaged for transport.

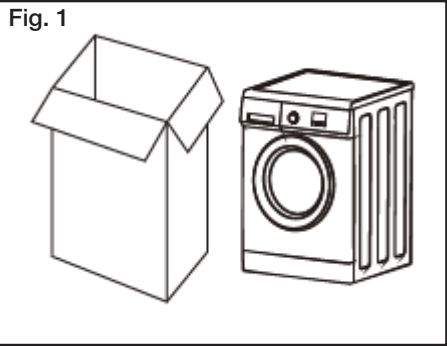

Checking the package contents

- Check all parts of the package against the scope of delivery list on the following pages and ensure you have received all items.
- Check the washing machine for any damage from transportation. Unwind the power cord to its full length and inspect it for damage. **Do not use the appliance if the appliance or its cord has been damaged or is not working properly.** In case of damage, or if anything is missing, please contact our after sales support centre for advice on examination, repair or return of the damaged product.
- Read this manual to familiarise yourself with all the parts and operating principles of the washing machine. Pay particular attention to the safety instructions on the previous pages.

Product Overview

Scope of delivery

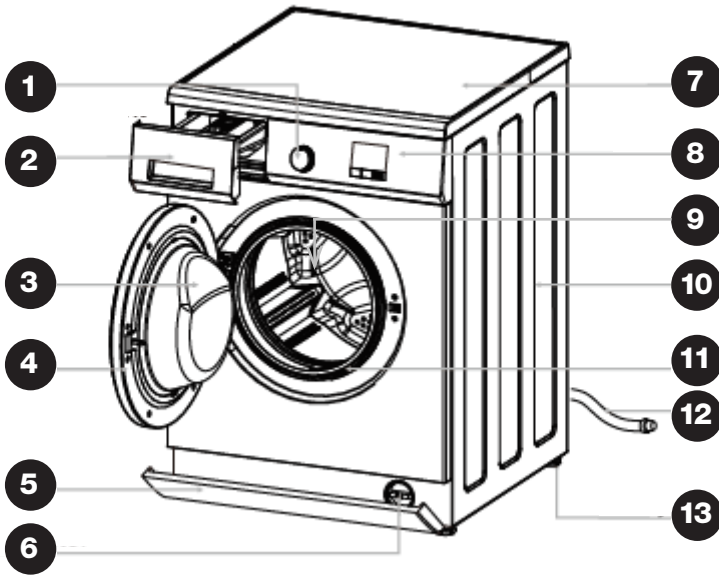

A Front view

- 1 Program dial (knob)
- 2 Detergent drawer
- 3 Door glass
- 4 Door
- 5 Lower cover
- 6 Drain pump filter
- 7 Top cover
- 8 Control panel with LED display
- 9 Wash/spin drum
- 10 Housing
- 11 Door seal
- 12 Drain hose
- 13 Adjustable feet

Product Overview (Cont.)

B Rear view

- 14 Power cord and plug
- 15 Transit bolts (4)
- 16 Back cover
- 17 Cold water inlet valve

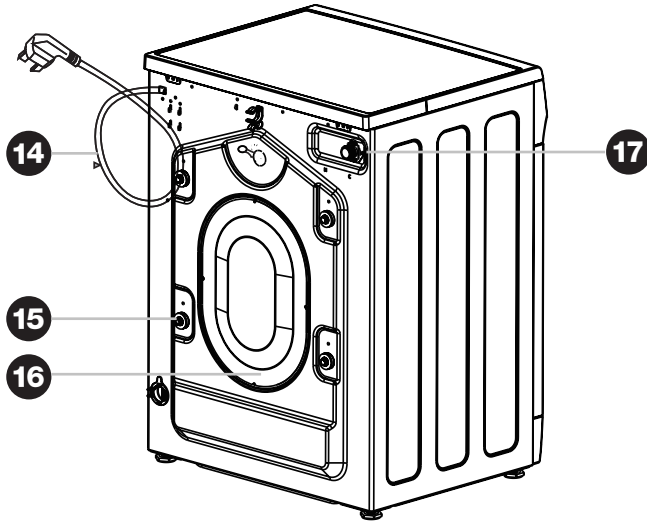

C Other inclusions

- 18 Cold water supply hose
- 19 Drain hose (not shown, attached to the rear of the machine)
- 20 Transit bolt caps
- 21 Drain hose support (elbow)
- 22 Instruction manual
- 23 Warranty certificate (not shown)

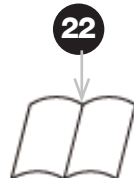
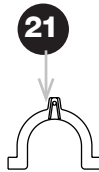
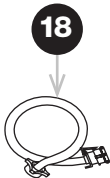

NOTE: Due to continued product improvement, images and illustrations in this manual may vary slightly from the product purchased. All images in this manual are for reference purposes only. Parts are not necessarily pictured to scale.

Installation

Removing the transit bolts

WARNING!

- Before installing the washing machine, you must remove the transit bolts from the back of the housing and cover the holes with the transit hole caps provided.
- **The bolts hold the drum in place during transport but they must be removed before use so the drum can move during the wash and spin cycles. Leaving the bolts installed will result in strong shock and noise during use, malfunction and serious damage to the machine.**

- Dismantle the four transit bolts from the back of the washing machine using an appropriate tool (Fig. 2).
- Keep the bolts in a safe place; you will need them again when moving the machine, if you move house, for example.
- Cover the holes with the supplied transit hole caps.

Fig. 2

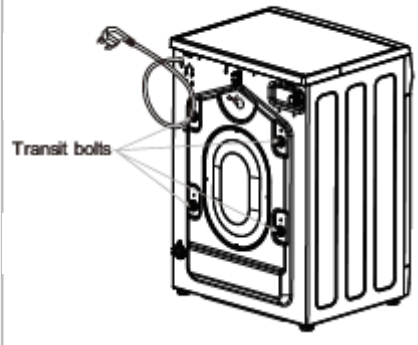

Selecting the location

Before installing the appliance, make sure the location meets the following requirements:

- A concrete floor is the most suitable installation surface for a washing machine, being far less prone to vibration during the spin cycle than wooden floorboards or a carpeted surface.
- The machine must be level and securely positioned. It must be protected from direct sunlight, water and weather.
- The distance between the machine and wall must be more than 10cm (Fig. 3).
- To avoid vibrations during spinning, the machine should not be installed on soft floor coverings. If the appliance must be placed on a carpeted surface, place a plastic mat underneath and ensure any ventilation openings in the base are not obstructed.

Fig. 3

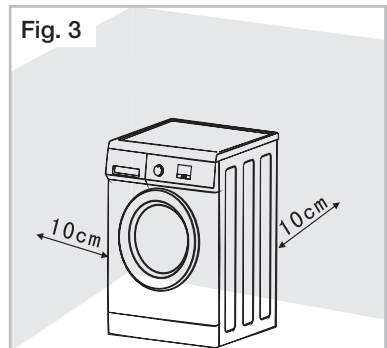

WARNING!

- Stability is important to prevent the washing machine from moving during operation.
- Make sure that the machine does not stand on the power cord.

Installation (Cont.)

Levelling the machine

WARNING!

It is very important to level the washing machine carefully, especially if your floor is uneven. Failure to do so may result in the machine shaking and moving during the spin cycle, or out-of-balance problems.

Place the machine on solid, dry and level ground. The machine must stand perfectly level on all four feet to ensure safe and proper operation. Incorrect installation may cause vibrations and noise and may cause the machine to move about.

To determine whether levelling is necessary, place a spirit level on top of the washer and hold it upright against the housing to identify any inclinations. If the machine needs levelling, proceed as follows (Fig. 4):

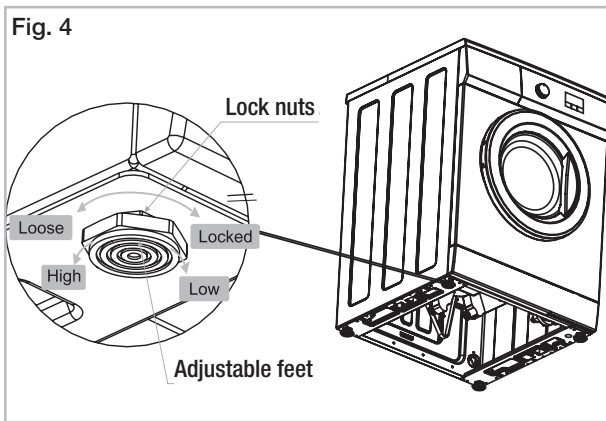

- Loosen the lock nut with a spanner, turning it **anticlockwise to loosen**.
- Adjust the foot by hand until it makes close contact with the floor. Turn it **clockwise to lower** the foot or **anticlockwise to raise** it.
- When the machine is level, use a spanner to turn the lock nut in a **clockwise** direction to tighten.

WARNING!

The lock nuts on all four feet must be screwed tightly against the housing, otherwise the machine may vibrate noisily during operation.

Installation (Cont.)

Installing the drain hose

WARNING!

- Do not kink or protract the drain hose.
- Position the drain hose properly in order to prevent water spillage onto the floor and potential damage.
- Never immerse the end of the drain hose in water.

The drain hose is installed at the back of the machine. For drainage of the washing water, you can install the other end of the hose two different ways: either directly into a laundry sink or into a standpipe.

Drain hose connection into a sink (Fig. 5)

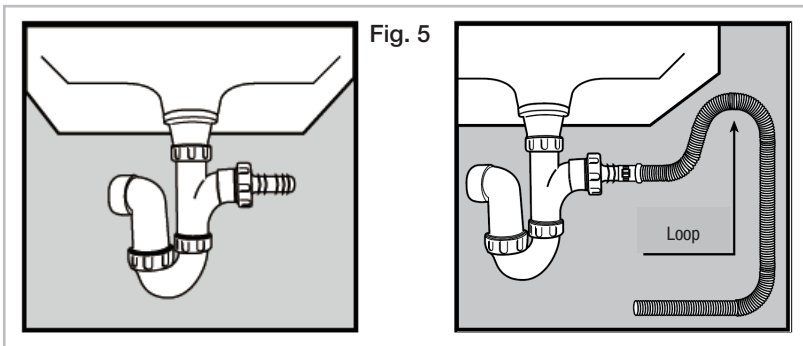

- If the spigot outlet has not been used before, remove any blanking plug that may be in place.
- Push the drain hose onto the spigot and secure with a clip, if required.
- Ensure a loop is formed in the drain hose to prevent waste from the sink entering the washing machine.
- If required, the drain hose may be extended to a length of 4m.

Installation (Cont.)

Drain hose connection into a standpipe (Fig. 6)

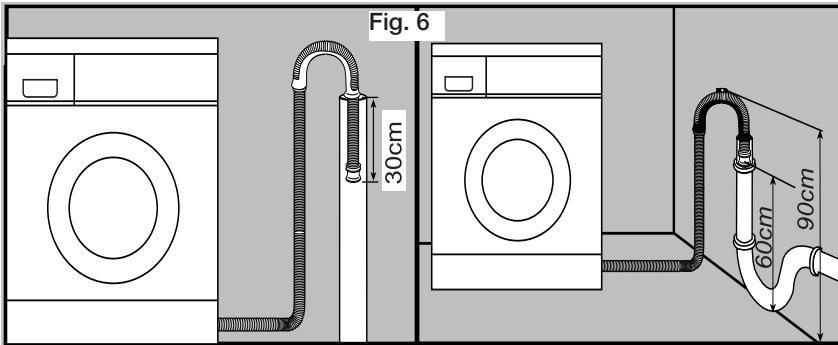

- Firstly, form a hook in the end of the drain hose using the supplied drain hose elbow.
- Place the drain hose into your standpipe, which should have an internal diameter of approximately 30mm, thus ensuring there is an air break between the drain hose and standpipe.
- When discharging into a standpipe, ensure that the top of the standpipe is no more than 90cm and no less than 60cm above floor level.

WARNING!

- Never lay down the drain hose as water will be discharged.
- Be sure the drain hose is properly routed so it will not kink or lift off the sink.
- Leave the drain hose affixed to the back of the machine.

FROST PROTECTION

- Do not install the washing machine in places where temperatures drop to below 0°C. The reliability of the electronic control unit may be impaired at temperatures below freezing point, and the machine's inlet valve and draining systems may get damaged as frozen hoses may burst or split.
- If temperatures drops to below 0°C, transfer it to an area with a warmer ambient temperature before use and ensure no residual water is frozen in hoses and pipes.

Installation (Cont.)

Connecting the water supply hose

WARNING!

- To prevent leakage or water damage, make sure to follow the instructions in this section when connecting the washing machine to your water supply.
 - Do not kink, crush, modify or sever the water inlet hose.
- Connect the supplied cold water supply hose to an ordinary laundry tap with a 3/4" thread (Fig. 7). Installation should comply with all requirements and regulations of your local water and building authorities.

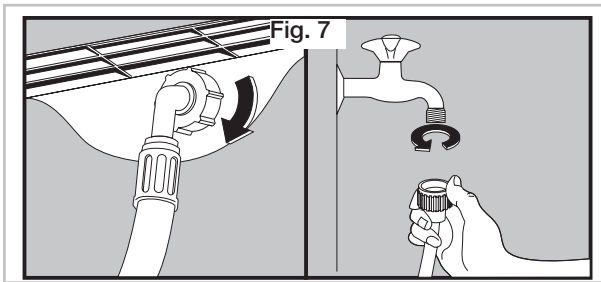

- When there is an inlet valve at the back of the machine, it must be connected to a cold water supply. (If there are two inlet valves, one must be connected to a cold water supply and the other to a hot water supply.) Follow the pictorial instructions below (Fig. 8) to complete the connection.

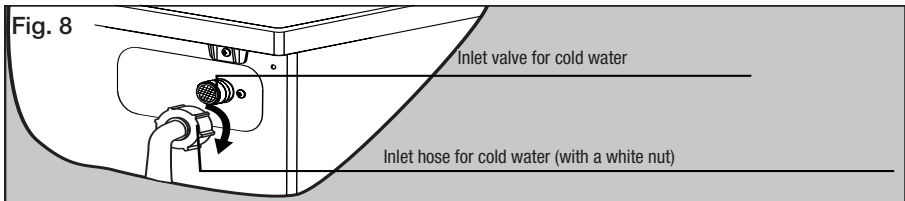

- Turn on the tap and check for leaks. In case of leakage, repeat the connection steps above, or tighten the nut more firmly. If your water pressure is strong, close the water tap completely, then open it slightly.

CAUTION!

- When tightening the coupling nut, take care not to damage the water inlet valve joint. Apply force evenly and do not twist the water inlet valve.
- Use only the new (supplied) hose with your new appliance. Do not use a hose from an existing machine, or one that has been used previously.

Installation (Cont.)

Electrical connection

WARNING! This appliance must be earthed.

In the event of a malfunction or breakdown, earthing will reduce the risk of an electric shock by providing a path of least resistance for the electric current.

This appliance is equipped with a cord having an equipment-earthing conductor and an earthing plug. The plug must be plugged into an appropriate outlet that is installed and earthed in accordance with all local standards and requirements.

Do not modify the plug under any circumstances. If the plug does not fit your outlet, consult a licensed electrician and have the outlet changed.

Power supply system

- Make sure the power supply system (current, power voltage and wire) at your home can meet the normal loading requirements of electrical appliances. The electrical voltage and circuit frequency are listed on the appliance rating label.
- **WARNING!** Only connect the washing machine to a single, grounded (earthed) electrical outlet. Do not overload the outlet, as overloading can result in fire or electric shock. Insert the power plug securely. Do not use a power adaptor or extension cord.

Electrical installation advice

- To avoid electric shock, fire and malfunction, do not install this machine in a damp place. Do not pull out or insert the plug with wet hands or bare feet. Do not expose the appliance, cord or plug to rain, moisture or other liquid.
- Do not kink or damage the power cord, and position it out of the way so no one steps on or places anything on the cord or against it.
- Ensure the washer is unplugged from the power supply before installation. The plug must be accessible after installation.
- **CAUTION!** Do not use a power adaptor or extension cord.
- Unless your home is already fitted with a residual current device (safety switch), we recommend installing an RCD with a rated residual operating current not exceeding 30mA to provide additional safety protection when using electrical appliances. See your electrician for professional advice.
- All electrical connections must be made by qualified personnel, and all instructions in this manual as well as local safety regulations must be observed.

Instructions

Control panel (Fig. 9)

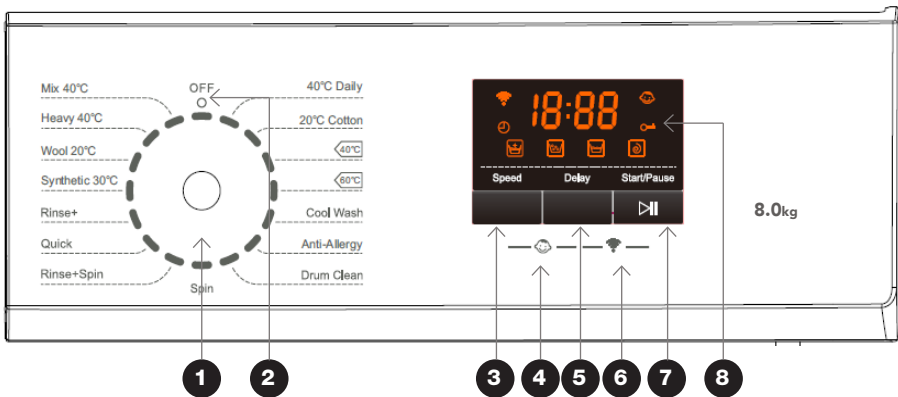

1 Program dial

Turn the program dial (knob) clockwise or anticlockwise to switch on the machine and select the required wash program (see page 18 for details of the programs). Once you press the **Start/Pause** button and the machine is running, the program cannot be changed.

2 OFF [O] position

At the end of a program, turn the knob to the [O] position to switch the machine off.

3 Speed button

Use this button to change a program's default spin speed (if available).

4 Child lock

- To activate the child lock after the washing cycle has started, press and hold the **Speed** and **Delay** buttons for three seconds. The child lock icon will light up on the display, indicating that all buttons and knob operations are ineffective. In an emergency you can power the machine off by turning the dial to the [O] position.
- To cancel the child lock, press and hold the **Speed** and **Delay** buttons for three seconds.
- You can only activate the child lock after the washing cycle has started. It will release automatically after the washing program has finished.

5 Delay button

Use this button to set the delay time (from 1 to 24 hours) of the start of a wash program.

6 Wi-Fi function

To activate the Wi-Fi function, turn on the machine, then press and hold the **Delay** and **Start/Pause** buttons at the same time until the unit emits a beeping sound. The Wi-Fi icon will start flashing rapidly. Follow the app prompts until the Wi-Fi icon illuminates steadily.

7 Start/Pause button

Press this button to start a wash program or to pause it. The door cannot be opened when the machine is paused.

8 Display screen









Shows the settings, time remaining, options, codes, etc. (see page 17 for details).

Instructions (Cont.)

Display icons (Fig. 10)



Table 1: Display icons

Icon	Meaning	Description
18:88	Digital display	Shows the time, speed, rinse times, error codes.
	Wi-Fi	<ul style="list-style-type: none"> – Flashes rapidly (several times per second) when the unit is ready for configuration with your mobile device. – Illuminates steadily when the Wi-Fi function is working.
	Delay time	Illuminates when the display shows the delay time.
	Child lock	Illuminates when the child lock has been set.
	Door lock	Illuminates when the door is locked.
	Rinse+	Illuminates when the Rinse+ program is selected.
	Main wash	<ul style="list-style-type: none"> – When applicable: illuminates in standby mode. – Flickers when the machine is in operation. – Stays brightly lit when the program is paused. – Turns off when the program is finished.
	Rinse	<ul style="list-style-type: none"> – When applicable: illuminates in standby mode. – Flickers when the machine is in operation. – Stays brightly lit when the program is paused. – Turns off when the program is finished.
	Final spin	<ul style="list-style-type: none"> – When applicable: illuminates in standby mode. – Flickers when the machine is in operation. – Stays brightly lit when the program is paused. – Turns off when the program is finished.

Instructions (Cont.)

Table 2: Default wash programs

Program	Max. Load (kg)	Time (hr:min) (A)	Temp. (°C) (B)	Rinse Times	Spin Speed (rpm) (C)
40°C Daily	8	1:20	40	2	0/400/600/ 800 /1000/1200
20°C Cotton	8	1:14	20	2	0/400/600/800/1000/ 1200
◀40°C (D)	8	3:17	40	3	0/400/600/800/1000/ 1200
◀60°C (D), (E)	8	3:10	60	3	0/400/600/800/1000/ 1200
Cool Wash	6	0:57	Cold	2	0/400/600/ 800 /1000/1200
Anti-Allergy	4.5	2:11	90	2	0/400/600/ 800 /1000
Drum Clean	0	1:14	60	2	600
Spin	8	0:11	—	0	0/400/600/800/ 1000 /1200
Rinse+Spin	8	0:16	—	1	0/400/600/800/ 1000 /1200
Quick	2.5	0:18	Cold	2	0/400/600/ 800 /1000/1200
Rinse+	8	1:34	Cold	4	0/400/600/ 800 /1000/1200
Synthetic 30°C	4	0:55	30	2	0/400/600/ 800
Wool 20°C	3	0:50	20	2	0/400/ 600
Heavy 40°C	8	1:39	40	3	0/400/600/ 800 /1000/1200
Mix 40°C	4.5	1:03	40	3	0/400/600/ 800 /1000/1200

NOTES



- (A) The running times are for the default programs and are for reference purposes only. The actual running times may be different depending on the type and weight of your wash load and the washing temperature.
- (B) The temperatures are the default temperatures. Actual water temperatures may differ slightly (+/-5°C) from the declared cycle temperature.
- (C) The default spin speed is printed **bold**.
- (D) The standard 40°C and 60°C wash programs are suitable for cleaning normally soiled cotton laundry. These are the most efficient programs in terms of combined energy and water consumptions for washing that type of cotton laundry.
- (E) This program was used for energy efficiency testing to the standard (1200rpm spin speed).

Instructions (Cont.)

Wash program details

40°C Daily: This program is suitable for cottons, linens or cotton mix fabrics, e.g. table linen, towelling, underwear, T-shirts etc. The default washing temperature is 40°C.

20°C Cotton: This program is suitable for washing cottons or linens at a 20°C.

 / : These programs are suitable for cottons, linens or cotton mix fabrics, e.g. table linen, towelling, underwear, T-shirts etc, at 40°C or 60°C.

Cool Wash: This program uses cold water for the wash and two rinses.

Anti-Allergy: This hygiene wash program is suitable for items that may be washed in very hot (90°C) water.

Drum Clean: This hot water drum clean program is recommended for use every three months to clean the inside of the wash drum.

Spin: This is a separate spin program for cotton and linen items.

Rinse+Spin: This is a separate rinse and spin program for items which can be washed in a cotton program. Do not add any detergent.

Quick: This program is suitable for small loads of items which require freshening up and which can be washed in a cotton program. It uses cold water on the default setting.

Rinse+: This wash program provides an additional rinse (4 rinses in total) after the wash, recommended for people with sensitive skin.

Synthetic 30°C: This program is suitable for washing items made of synthetic or mixed fabrics, underwear, coloured garments or non-shrink shirts. The default washing temperature is 30°C.

Wool 20°C: This program is suitable for machine-washable or hand-washable wool or wool blend fabrics. The default washing temperature is 20°C. Sort the garments into light and darker coloured items and use a wool wash detergent. At the end of the wash, take your garments out of the machine straight away and place them flat on a suitable surface for air-drying. If washing hand-washable silks, reduce the spin speed.

Heavy 40°C: This program is suitable for washing heavier items which can be washed at 40°C in a cotton program.

Mix 40°C: This wash program is suitable for easy care laundry items which can be washed at 40°C.

Instructions (Cont.)

Before first use

CAUTION!

- Make sure the washing machine is properly and securely installed before using it.
- Before using the washing machine for washing clothes, run a complete washing cycle without clothes, using the drum clean program.

Before using the washing machine for the first time, please review the following important points and make sure that:

- **All transit bolts are removed.**
- The washing machine is stable and level. If necessary, adjust the levelling feet to stabilise the machine (see page 11).
- The water supply hose is properly installed (see page 14) and the water tap is open.
- The power plug is firmly inserted into a nearby power point and power is switched on to the outlet.
- The drain hose is properly installed and secured into the laundry sink or a standpipe (see pages 12–13).
- **Before using the washing machine for the first time, run a complete drum clean program without laundry items and without any detergent.**

Door lock

- The door of the front load washing machine locks automatically when the machine is working. It cannot be opened without first pausing the wash program. To unlock the door, press the **Start/Pause** button. Then turn the program dial (knob) to the [O] position: the door will unlock after two minutes.
- The door will **not unlock** when the temperature inside the drum is above 60°C, and/or when the water is above a certain level.
- At the end of a wash program, the door will unlock after two minutes.
- Suds may flow out of the open door if it is opened during the wash cycle. Beware of suds escaping from the machine and have a cloth/towel ready for catching spills.

CAUTION!

- For your safety, do not turn the program dial to the position [O] position and remove your wash load while the machine is running, or when the power supply is cut off. The water temperature may be high and it may scald you. The door will automatically unlock at the end of a wash program when the temperature of the drum has cooled down.
- Do not attempt to open the door forcibly. Doing so is unsafe and will cause damage to the locking mechanism.





Instructions (Cont.)

Detergent recommendations

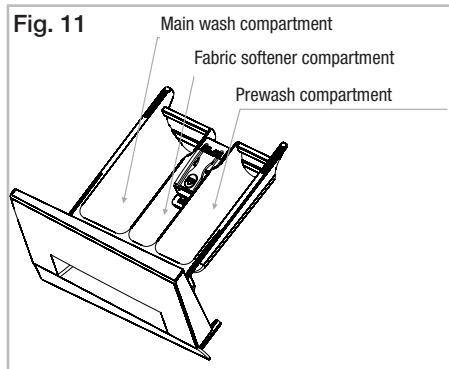
WARNING!

- Do not use flammable and explosive or toxic solvents, petrol, alcohol or other chemicals in the machine.
- Keep detergents and clothing care preparations out of reach of children.
- **Only use low-sudsing detergent and clothing care preparations that are suitable for use in a front load washing machine, or in a top and front load machine.** Detergents for top load machines are unsuitable because they tend to produce too much suds, which may cause overflowing from the detergent drawer.
- Use detergent in the amounts recommended on the detergent packaging. Dosage depends on your amount of washing, the degree of soiling, water hardness and the washing performance of your detergent. Using too little detergent will give poor washing results, but too much will affect rinse performance and may cause overflow of suds, which could interfere with machine operation. **Do not overfill detergent!**
- Pull open the detergent dispenser drawer and add detergent, as illustrated (Fig. 11) and described below.



-  or  The detergent compartments on the left and right side of the drawer are for low-sudsing detergent for the main wash (left) and prewash (right). If you are using powder detergent, you dissolve it in some water before adding it to one of the two compartments.
-  or  The middle compartment is for fabric softener. It will be dispersed through the washing during the last rinse cycle. Concentrated fabric softeners should be diluted as required. Do not exceed the maximum level mark.

Instructions (Cont.)

Before each wash

- **Before loading the washing machine**
 - Ensure that the washer is stable, level and properly connected to the power supply.
 - Check that no young child or pet has climbed into the drum.
 - Ensure that the water inlet hose and the drain hose are properly connected.
 - Ensure that the drain hose is securely connected into the drain spout or sink.
- **When loading the machine**
 - Empty all pockets of clothing to be washed. Hard, sharp objects such as coins, safety pins, paper clips, bra wires, nails, screws or stones can cause extensive damage to the appliance and block the pump. Any damage or malfunction resulting from foreign objects is not covered by your warranty and may lead to expensive repairs.
 - Turn items with zippers inside out, close zippers, hooks and eyelets, fasten buckles and tie fabric belts. This will also help reduce impact noise when the items hit against the turning drum.
 - Brush dirt, sand or pet hair off clothes and turn pockets inside out. Pretreat stains.
 - Turn items that pill easily inside out.
 - Sort your washing into appropriate loads: whites, darks, cottons, synthetics, woollens, etc. Place small or delicate items into a wash bag for protection.
 - Put your washing in the machine, loading items uniformly in the drum. For best results, include both larger and smaller items in a wash.
 - Do not overload the washer; the maximum dry washing capacity is 8kg.
 - When closing the appliance door prior to starting the unit, ensure that items are not jammed in the door.
- **CAUTION: Do NOT wash the following items in the washing machine:**
 - Jackets, raincoats, sleeping bags, fishing coats and similar clothes.
 - Carpets or floor rugs.
 - Underwire bras – instead, ensure these are placed in a closed garment bag before washing in the machine.
 - Clothes that have any residues of flammable materials, as this may result in fire or explosion. For example, articles that have been cleaned in, washed in, soaked in, or dabbed with industrial chemicals, or combustible or explosive substances (such as wax, oil, paint, petrol, alcohol, degreasers, dry-cleaning solvents, kerosene, etc.). Items containing such substances must be washed by hand or rinsed thoroughly before machine-washing them.
 - Single items, as this can cause unbalance problems during the wash or spin cycles. We suggest you always add a few more items to the wash to avoid such problems.
 - Items such as ties, suits, evening attire; silk or fur attire; or anything else labelled unsuitable for machine-washing. Always check the garment label (see page 30).

Instructions (Cont.)

Step-by-step washing instructions

1. **Connect:** Plug the machine in, switch on power to the outlet and open the water tap.
2. **Load:** Open the door of the washer and load the machine following the guidelines on the previous page.

Mixing both large and small items gives better wash results and also helps distribute the load evenly during spinning. You will achieve the most efficient energy and water use when washing a full load. However, do not overload the machine as this causes creases and reduces cleaning efficiency.

When your washing is properly loaded in the machine, close the door and ensure that no items are caught in the door (Fig. 12).

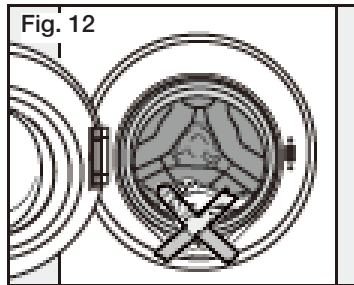

3. **Add detergent:** Pull out the detergent dispenser and add detergent as required, then close the dispenser (see page 21 for instructions).
4. **Select a program:** Rotate the **Program dial** to switch on the washing machine and select the required program. Always check your clothing labels for recommended wash and care instructions (see page 30).
5. **Start:** Press the **Start/Pause** button.
6. **Finish:** At the end of the wash program, the buzzer will sound to alert you that the program has finished. The machine will change into standby mode after 10 minutes of inactivity. Turn the dial back to the [O] position. Unplug the washing machine from the power supply and close the water tap.
7. **Unload:** Open the door and unload the washing machine. We recommend you leave the door slightly ajar so the drum can dry properly and to prevent mould and odour development.

Wi-Fi Control

This **AKAI Home** 8kg Front Load Washing Machine features Wi-Fi technology, which enables you to control the appliance remotely from wherever you are—at work, at play or on the go—so that on your arrival at home your washing is done, ready for drying.

How it works

Before you leave your home, get your washing ready, load it in the machine, add detergent and close the door. You can then control the machine from anywhere using your mobile phone: set the required washing program, spin speed and other functions, start the machine and check the program status. The washing machine works in conjunction with your mobile device, using your home Wi-Fi network router to communicate with the machine.

Controlling the washing machine remotely is very easy. You will need:

- an Android smartphone or tablet, or an Apple iPhone or iPad
- an internet connection at your home
- a Wi-Fi network router set up at home.

You must also have our **AKAI Home** app installed or updated on your smartphone or mobile device. This app is available from Google Play Store or Apple App Store.

Initial set-up

Upon installation of your new washing machine, or when you have changed your mobile device or wireless router, you will have to set up the communication channel between the devices. In order to do this, make sure you have the **AKAI Home** app installed or updated on your mobile device, your Wi-Fi router is switched on and your mobile device connected to your home Wi-Fi network.

On your mobile device, tap on the **AKAI Home** app. It will open and take you to the log in page. Before you log in, please follow the prompts to register your account (using your email account) and set a password.

IMPORTANT!

Before you can control your washing machine remotely, you must activate (reset) the Wi-Fi module:

- Turn the program dial to turn on the machine.
- Press and hold the **Delay** and **Start/Pause** buttons at the same time until the unit emits a beeping sound. On the LED display, the Wi-Fi icon will start flashing rapidly.
- Follow the app prompts until the Wi-Fi icon illuminates steadily.



Wi-Fi Control (Cont.)

On the main device list page you can add the washing machine from the product list. You may have to confirm your Wi-Fi name and password, then follow the prompts to add the machine.

While the washing machine is being added, the progress will be displayed.

On completion, when your device has been successfully added, follow the prompts to name the device.

You can then enter the device's main control page.

Alternative pairing mode

If the device is not responding you will get a message with a few prompts to check the Wi-Fi details.

If you want to switch the pairing mode, follow the prompts.

After you have confirmed your Wi-Fi network and password, connect your mobile phone to the device's hotspot, then go back to the app and continue to add the device.

Device sharing

The device only recognises ONE registered user. But you can share access to the device with other members of your household if they have the **AKAI Home** app installed and updated on their phone. To share the device, proceed as follows:

On the device's main control page, click the edit symbol in the corner, then select to share the device and follow the prompts.

Using the AKAI Home app

Operating the washing machine with the **AKAI Home** app is self-explanatory. You can select the washing program, spin speed and delay time, start the machine, check the program status, and set/cancel the child lock (once the program has started). The app will sound an alarm when the program has finished. In case of a malfunction, it will display the relevant error message (see page 28 for details).

Wi-Fi Control (Cont.)

Adding the AKAI Home app to your Google Home app *

- Open your Google Home app.
(Before you can link your **AKAI Home** app to your Google Home app you will have to have a Google Home account set up.)
- From the home screen of the Google Home app, tap [**Add**].
- Tap [**Set up device**], then tap [**Have something already set up?**] under the “Works with Google” banner.
- Using the magnifying glass icon, search for **AKAI**.
- Tap the **AKAI Home** app and enter your **AKAI Home** account details and password, then tap [**Sign in**].

Adding the AKAI Home app to your Alexa account *

- Before you can link your **AKAI Home** app to your Alexa account you will have to have an Alexa account set up.
- From the home screen of the Alexa app, tap the three bars in the top left hand corner. Tap [**Skills & Games**], then use the magnifying glass icon to search for **AKAI**.
- Select the **AKAI Home** app. Ensure you have followed the steps listed, then select [**Confirmed**] and tap [**Next**]. Enter your **AKAI Home** account details and password, then tap [**Sign in**].

* These instructions for adding the **AKAI Home** app are of a general nature only. Detailed steps or specific messages from your Google Home or Alexa account may vary depending on the version.

Smartphone and Wi-Fi specification requirements

Minimum smartphone specifications

Android 5.0 version or later, IOS 10.0 version or later

Wireless network requirements of the Wi-Fi module

Frequency band	FCC/IC: 2.412 to 2.462 GHz, CE: 2.412 to 2.472 GHz
Wi-Fi standard	IEEE 802.11 b/g/n 2412 to 2472: correspond to channels 1 to 13 2412 to 2462: correspond to channels 1 to 11
Data transmission rate	802.11b: 1, 2, 5.5 or 11 (Mbps) 802.11g: 6, 9, 12, 18, 24, 36, 48 or 54 (Mbps) 802.11n: HT20 MCS0 to MCS7
Antenna type	PCB antenna

Wi-Fi Control (Cont.)

Wi-Fi troubleshooting

Problem	Possible cause and solution
<p>During the set-up, the washing machine cannot be configured successfully.</p>	<p>Check and ensure you have internet reception and your mobile phone and the washing machine are connected to the same Wi-Fi network.</p>
	<p>Check and ensure your Wi-Fi password is correct.</p>
	<p>Check and ensure that no firewalls or other restrictions are set.</p>
	<p>Check and ensure that the router works normally — check the network requirements.</p>
	<p>Ensure that the washing machine, router and mobile are all on the same Wi-Fi network and within the signal range.</p>
<p>I cannot control the washing machine with my mobile.</p>	<p>If a message is displayed to alert you to an identification failure, the washing machine has been reset and the mobile phone lost control permission. You need to reconnect the phone to the washing machine, following the set-up instructions in this manual.</p> <p>If after these steps you still cannot control the washing machine with your mobile, please delete the machine from your device list and reconnect again.</p>
<p>My mobile phone cannot find the washing machine.</p>	<p>If a message is displayed to alert you that the device is offline, please check and ensure that your washing machine is connected to your mains supply and power is switched on at the outlet.</p> <p>Also ensure that your router is connected to the mains supply and that the router and your mobile phone are properly connected to your Wi-Fi network.</p>

FAQs and Troubleshooting Guide

When the following problems occur, the microcomputer inside the washer will detect the abnormal condition, display an error message and the washer will stop operating. If after your remedial action the problem persists, please contact our after sales support centre for advice or to book a service.

Table 3: Error messages

Error message	Possible cause	Solution
[E01]	No water	<ul style="list-style-type: none">• Ensure the tap is open.• Check the water inlet valve filter and ensure it is clean, unblocked and undamaged.• Ensure the drain hose is properly fitted.• Check for a water stoppage in your area.
[E02]	Door lock alarm	<ul style="list-style-type: none">• Ensure the door is properly locked.• If a garment is caught in the door, place it inside the drum and lock the door properly.• If the door lock is damaged, call for a service.
[E03]	Continuous drainage	<ul style="list-style-type: none">• Check and ensure the drain hose is not squashed or kinked.• Check and ensure the drain hose filter is unblocked.• Check and ensure that nothing is caught in and blocking the drain hose.
[E04]	Water overflowing	<ul style="list-style-type: none">• Ensure the water inlet is undamaged.• If the water sensor malfunctions, call for a service.
[E05]	The motor does not work.	<ul style="list-style-type: none">• If the machine is overloaded, an overheat protection has been triggered. Switch off the machine, let it cool, reduce the load and restart.• If the motor is malfunctioning, call for a service.
[E06]	Heater problem	Call for a service.
[E07]	Temperature sensor problems	Call for a service.

FAQs and Troubleshooting Guide (Cont.)

Not all unusual incidents you may encounter with your washing machine are faults, or cause for concern. Check in the list below what issues may arise and why. Also check in the table on the previous page for solutions to problems that may be resolved without the need for a service call.

If none of the solutions offered below and on the previous page help you solve the problem, please contact our after sales support centre.

Table 4: Troubleshooting

Problem	Possible cause	Solution
The washing machine does not start up.	<ul style="list-style-type: none"> The door is not closed properly, or items are caught up in the door. The plug is not firmly plugged in. Have you selected a program and pressed the Start/Pause button? The water tap is closed. 	<ul style="list-style-type: none"> Check and ensure no items are caught in the door, then close the door properly and restart. Ensure you have properly inserted the plug, selected a program and pressed the Start/Pause button. Ensure the water tap is open.
The door cannot be opened.	<ul style="list-style-type: none"> The machine's safety protection design is working. The water temperature is still too high. 	<ul style="list-style-type: none"> Wait a few moments after the end of a program before opening the door. Wait until the water has cooled.
No water	<ul style="list-style-type: none"> The water tap is closed. Water is frozen in the supply hose. The water inlet valve filter is blocked. There is a water stoppage in your area. 	<ul style="list-style-type: none"> Ensure the tap is open. See page 33 for solving water freezing issues. Ensure the water inlet valve filter is clean and unblocked. Restart when the water is back.
Water leakage	<ul style="list-style-type: none"> The water supply hose or drain hose are not tightly connected. The drain hose is blocked. 	<ul style="list-style-type: none"> Check and ensure both hoses are securely connected. Check and ensure the drain hose is not blocked.
Abnormal noise	<ul style="list-style-type: none"> The transport bolts have not been removed. The machine is installed on an uneven or unstable floor. A loose object is knocking against the drum walls. 	<ul style="list-style-type: none"> Make sure the transport bolts have been removed. Make sure the machine is installed on a solid, level floor. Ensure to check pockets before the wash and remove any coins, hairpins, etc.

Other Useful Information

Garment care symbols

When choosing a wash program, check for any labels in your clothes and follow the instructions. Below are some commonly used symbols and explanations what they mean.

Fig. 13

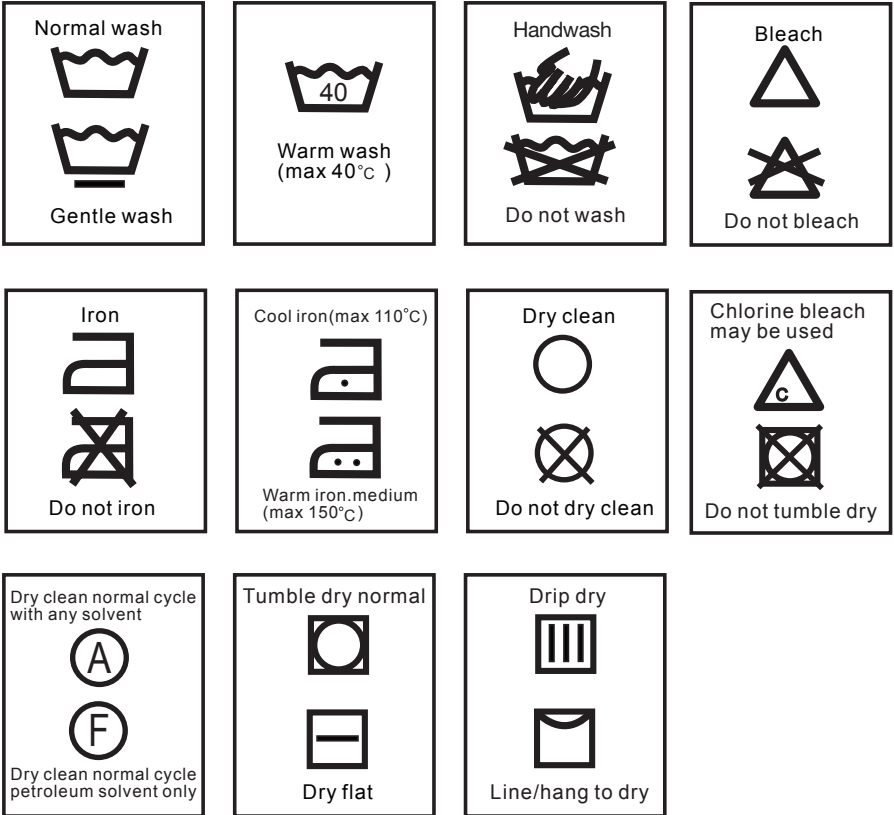

Other Useful Information (Cont.)

Cleaning and care

To prolong the service life of the washing machine, keep it in good condition and perform regular maintenance.

WARNING!

For any type of cleaning and maintenance, make sure the washing machine is disconnected from the mains power supply and the water tap is closed.

Cleaning the cabinet (when required)

- Use a soft cloth to wipe any water or dirt off the washer housing.
- To remove dirt and stains, use a mild detergent solution and a damp cloth. Squeeze it almost dry to avoid leaving water residues.

WARNING!

Do not use any solvents, alcohol, harsh chemicals, alkaline or abrasive cleaning agents, or sharp objects, to avoid damaging the surface. Do not spray water directly onto the washer housing.

Cleaning the drum (every three months)

- Make sure all laundry items are removed from the drum, then wipe it clean with a soft dry or damp cloth.
- If you notice any rust residues left inside the drum from washing items with metal parts (such as buttons or zippers), wipe the residues off immediately with chlorine-free detergent. Never use steel wool.
- To remove dirt and/or detergent residues and scum build-up from the inside and outside of the washing machine's drum, run the **Drum Clean** program without any clothes or detergent.

CAUTION!

Cleaning the inside of your washing machine regularly is particularly important **if you frequently use a cold wash cycle**, especially if you also use a fabric softener. Liquid detergents can cause detergent scum to build up around the outside of the drum, which cold water will not remove and which can cause bacteria, unpleasant odours, and eventually soiling of your wash load.

Other Useful Information (Cont.)

Cleaning the detergent drawer (when required)

Remove detergent residues regularly. The detergent dispenser may be removed for cleaning.

- Pull open the dispenser drawer until you feel a resistance. Press down the release catch and at the same time pull the drawer right out of the machine (Fig. 14).
- Remove the siphon from the compartment and clean it.
- Clean the drawer using a brush and warm water (Fig. 15).
- Use a bottle brush to remove detergent residues from inside the housing (Fig. 16).
- Wipe all parts dry with a clean cloth, then reinstall the drawer back into its space.

NOTE: Do not use any solvents, alcohol, harsh chemicals, alkaline or abrasive cleaning agents, or sharp objects, to avoid damaging the surface.

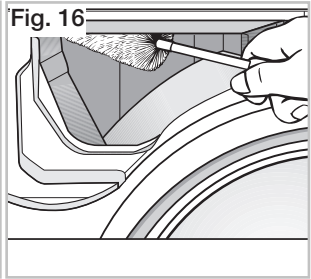
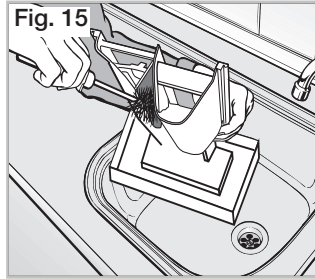
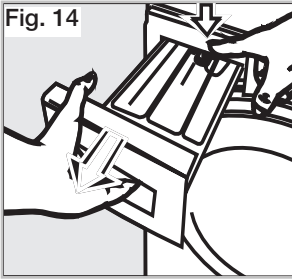

Cleaning the door seal and glass (after each wash)

After each wash:

- Wipe the glass and seal to remove lint and stains. A build-up of lint can cause leaks.
- Check for coins, buttons and other small objects in the seal creases (Fig. 17) and remove them.
- Leave the door slightly ajar so the inside can dry properly. This will also help prevent the development of mould or odours.

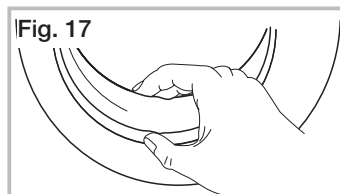

Other Useful Information (Cont.)

Cleaning the water inlet filter

To avoid blockage of the mesh filters at the water tap or hose after long time use, we recommend you clean these filters every 6 months, or more often if there are frequent interruptions to the water supply.

CAUTION!

Before cleaning the water inlet filter, make sure you have turned off the water supply at the tap.

- Use pointed nose pliers to withdraw the plastic filter from the water inlet valve at the back of the washing machine (Fig. 18).
- Clean the filter with a soft brush, then assemble the cleaned filter back into the valve.
- Reconnect the water supply hose to the water tap on your wall and to the water inlet valve at the back of the washing machine. For more detailed connection instructions, please refer to page 14.

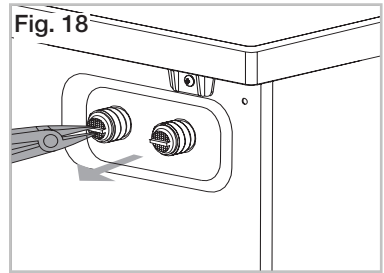

Freezing conditions

If the washing machine is exposed to temperatures below 0°C, you should take certain precautions to prevent water freezing in the pipes.

1. Turn off the water tap.
2. Unscrew the water inlet hose.
3. Unhook the drain hose from the rear support and position the end of this hose and that of the inlet hose in a bowl. Run the spin program.
4. Disconnect the appliance.
5. Reconnect the inlet hose and reposition the drain hose.
6. When you intend to start the machine up again, make sure that the room temperature is above 0°C.

If the temperature drop was unexpected and water has frozen in the water supply hose, proceed as follows:

1. Wrap a hot towel around the water tap and the water supply hose joint.
2. Disconnect the water supply hose and soak it in a tub of hot water of approximately 50°C.
3. Pour about 2-3 litres of hot water (approximately 50°C) into the drum of the washing machine.
4. When all frozen water has thawed, reconnect the water supply hose, open the tap and start the machine to check whether all blockages have been removed.

Other Useful Information (Cont.)

WARNING!

- For any type of cleaning and maintenance, make sure the washing machine is disconnected from the mains power supply and the water tap is closed.
- Do not open the pump filter cover during the course of a wash program.
- If you are checking the drain pump after a hot water wash, take particular care as any residual water in the machine may be hot. Wait until the water has cooled down to avoid burns.

Drain pump maintenance

In order to avoid blockages created by excess lint, threads or items such as bobby pins, coins, etc., check the drain pump filter regularly, especially if the machine fails to drain the water or spin properly, or if you notice any unusual noises during the drain or spin cycles. We recommend you clean the filter every two months, or when there is a fault and the error code [**E03**] is displayed on the screen.

CAUTION: If you are checking the drain pump after a hot water wash, wait until any residual water has cooled to a safe level.

1. Open the lower cover using a screwdriver (Fig. 19).
2. Place a container underneath the drain pump filter when removing it, and always keep a rag nearby to dry up any water spillage.
3. Remove the plug. Any residual water will drain out (Fig. 20).
4. Remove any foreign objects. Clean the filter carefully with water and a soft brush (Fig. 21).
5. Screw the filter plug back into position.
6. Close the pump filter cover and secure it with the screw.

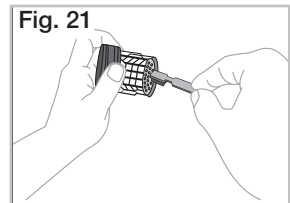
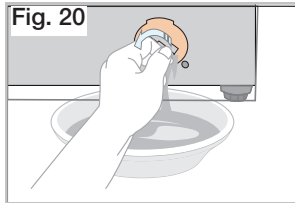
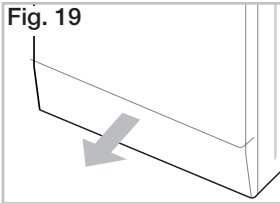

WARNING!

Make sure to reinstall the drain pump filter and close the cover panel securely, otherwise water may leak.

Other Useful Information (Cont.)

Storage

If the appliance is not going to be used for an extended period of time, please unplug the machine from the power supply and disconnect all hoses. Clean the machine and filters as described on the previous pages. Let the machine air-dry thoroughly, then store it in the original packaging in a dry location, out of reach of children.

Service and repair

If the appliance is damaged, do not attempt to repair it yourself. If it requires repair or service, contact our after sales support centre to arrange for examination and repair.

Specifications and technical parameters

Rated capacity (washing/spinning)	8kg
Rated voltage and frequency	220–240V~ 50Hz
Rated power	2100W
Water pressure	0.02MPa – 0.8MPa
Liquid ingress protection	IPX4
Weight	65kg
Dimensions	595mm (W) x 545mm (D) x 845mm (H)

Compliance

This appliance has been fully tested and meets all requirements as set out by standards AS/NZS 60335.1 and AS/NZS 60335.2.7



The RCM Mark (Regulatory Compliance Mark) indicates that the product complies with the relevant guidelines of the ACMA as well as corresponding government requirements for the safety of electrical devices.

Responsible disposal

- Packaging materials are recyclable. Please dispose of them responsibly for recycling.
- At the end of its working life, do not throw this appliance out with your household waste. Electrical and electronic products contain substances that can have a detrimental effect on the environment and human health if disposed of inappropriately. Observe any local regulations regarding the disposal of electrical consumer goods and dispose of it appropriately for recycling. Contact your local authorities for advice on recycling facilities in your area.

Warranty returns

Should you for any reason need to return this product for a warranty claim, make sure to include all accessories with the product.

Product does not work?

If you encounter problems with this product, or if it fails to perform to your expectations, make sure to contact our After Sales Support Centre on 1300 886 649 for advice.