

FULLY INTEGRATED BAR FRIDGE & FREEZER

MODEL AINT119/2

ARTUSI
THE ART OF LIVING

COMING SOON



24 MONTH WARRANTY



60CM



119L FRIDGE CAPACITY



16L FREEZER CAPACITY



LED LIGHTS



2 SHELF POSITIONS



DEFROST MODE



LOW NOISE



10AMP POWER CONNECTION

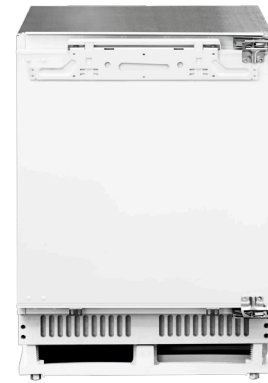

3 star energy label

*integrated door panel not supplied

PRODUCT INFORMATION

FINISH

- white interior

FEATURES

- digital temperature control
- Automatic fridge defrost
- Manual freezer defrost
- Adjustable refrigerator temperature
- Mechanical knob thermostat
- power LED cavity light
- 12 hour storage in the event of power failure
- Single compressor
- Static vented cooling system
- Current (A) <10
- Noise: 40db/A

DOOR

- Supplied with right hand hinge (reversible)
- heavy duty hettich integrated door hinges

CAPACITY & INTERIOR

- 111L total net capacity
- 95L (fridge)
- 16L (freezer)
- 2kg freezing capacity
- 2x adjustable glass shelves (1x split shelf with direct access to crispers)
- 2 x crystal clear door shelves
- 2 x crispers

DISCLAIMER

Eurolinx PTY LTD, is continually seeking ways to improve the design specifications, aesthetics and production techniques of its products. As a result alterations to our products and designs take place continually. Whilst every effort is made to produce information and literature that is up to date, this brochure should not be regarded as an infallible guide to the current specifications, nor does it constitute an offer for the sale of any particular product. Product dimensions indicated in our literature is indicative only. Actual product only should be used to define dimension cut outs. Distributors, and retailers are not agents of Eurolinx and are not authorized to bind Eurolinx by any express or implied undertaking or representation.

TEMPERATURE

- 5 cooling levels (fridge)

ACCESSORIES

- 1x transparent iceholder trays
- 1x transparent egg tray



EAN 9347777004710

AR23112021

FOLLOW US ON:  [instagram.com/artusi_appliances](https://www.instagram.com/artusi_appliances)

 www.linkedin.com/company/eurolinx-pty-ltd-t-a-llve/

Australia National Telephone Number 1300 (694 583) New Zealand Telephone Number 64 3 344 5913
Artusi showroom hours: Tuesday to Friday - 9am-5pm, Saturday - 10am-4pm, Sunday and Monday - closed
* Melbourne showroom hours: Tuesday to Saturday - 10am-4pm

[artusi.com.au](https://www.artusi.com.au)

NSW & ACT (Head Office)
48-50 Moore Street
Leichhardt
F 02 8569 4699

QLD
1/42 Cavendish Road
Coorparoo
F 07 3397 0850

WA & NT
Unit 10/55 Howe Street
Osborne Park
F 08 9201 9188

New Zealand
PO Box 11,160
Sockburn Christchurch
F 03 344 5906

FULLY INTEGRATED BAR FRIDGE & FREEZER

MODEL AINT119/2

ARTUSI
THE ART OF LIVING

TECHNICAL DIAGRAM

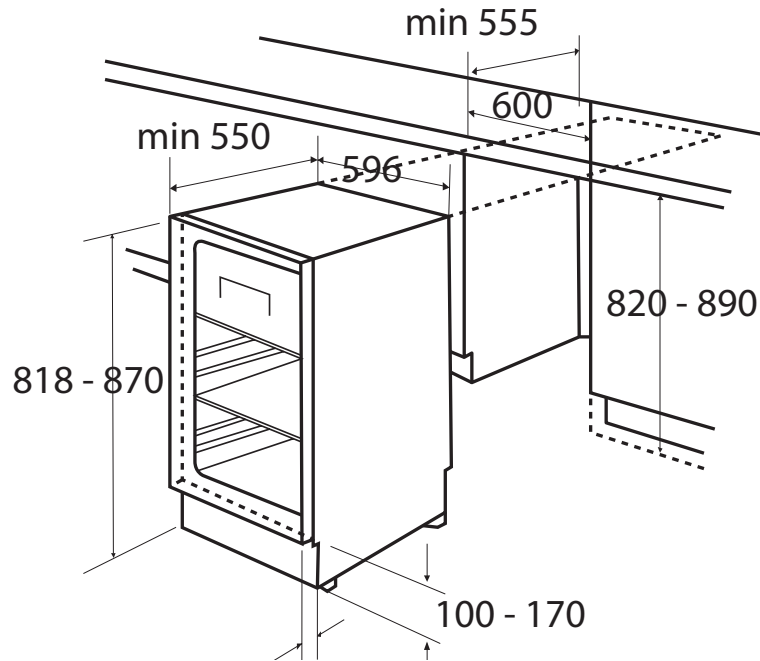

NB: drawings are not to scale — they are to be used for detailed installation instructions, please refer to user guide.

EAN 9347777004710

AR23112021

DISCLAIMER

Eurolinx PTY LTD, is continually seeking ways to improve the design specifications, aesthetics and production techniques of its products. As a result alterations to our products and designs take place continually. Whilst every effort is made to produce information and literature that is up to date, this brochure should not be regarded as an infallible guide to the current specifications, nor does it constitute an offer for the sale of any particular product. Product dimensions indicated in our literature is indicative only. Actual product only should be used to define dimension cut outs. Distributors, and retailers are not agents of Eurolinx and are not authorized to bind Eurolinx by any express or implied undertaking or representation.

AINT119/2 Fully Integrated Bar Fridge & Freezer
Voltage (V) 220-240
Total annual energy consumption 302 (kW/)
10 AMP plug and cord
150cm power cord length

FOLLOW US ON:  [instagram.com/artusi_appliances](https://www.instagram.com/artusi_appliances)

 www.linkedin.com/company/eurolinx-pty-ltd-t-a-lve/

Australia National Telephone Number 1300 (694 583) New Zealand Telephone Number 64 3 344 5913
Artusi showroom hours: Tuesday to Friday - 9am-5pm, Saturday - 10am-4pm, Sunday and Monday - closed
* Melbourne showroom hours: Tuesday to Saturday - 10am-4pm

[artusi.com.au](https://www.artusi.com.au)

NSW & ACT (Head Office)
48-50 Moore Street
Leichhardt
F 02 8569 4699

QLD
1/42 Cavendish Road
Coorparoo
F 07 3397 0850

WA & NT
Unit 10/55 Howe Street
Osborne Park
F 08 9201 9188

New Zealand
PO Box 11,160
Sockburn Christchurch
F 03 344 5906