

6KG FRONT LOAD DRYER

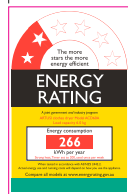

MODEL ACD60A



24 MONTH WARRANTY



60CM



6KG DRYING CAPACITY



CHILD LOCK



10AMP POWER CONNECTION

PRODUCT INFORMATION

FINISH

- white enamel

FEATURES

- PTC heating element (quick dry)
- easy-to-clean double-layer flint filter
- high-speed rotating turbo fan
- automatic disinfection
- upright floor mounted
- upside-down wall mounted
- thermostat: 60°C
- centrifugal blast type motor
- mechanical controls
- <6% residual water
- drying time setting: 0–200 minutes
- direct ducting: rear vent for optional fitting of supplied flexible ducting kit
- one-way drum rotation

CAPACITY & INTERIOR

- 6kg dry weight capacity
- stainless steel drum
- net weight: 23kg

POWER

- inner drum speed: 50 rpm
- input power: 800–1400W
- heating power: 700/1300W
- motor output power: 90W

SAFETY

- automatic overheat cut off
- child safety lock
- auto stop when door opened

DRYING CAPACITY	DRYING TIME (approx)	
	Regular (minutes)	Airing (minutes)
approx 2kg	30	55
approx 3kg	60	110
approx 4.5kg	200	120
approx 6kg		200

EAN 9347777001252

AR09042021

DISCLAIMER

Eurolinx PTY LTD, is continually seeking ways to improve the design specifications, aesthetics and production techniques of its products. As a result alterations to our products and designs take place continually. Whilst every effort is made to produce information and literature that is up to date, this brochure should not be regarded as an infallible guide to the current specifications, nor does it constitute an offer for the sale of any particular product. Product dimensions indicated in our literature is indicative only. Actual product only should be used to define dimension cut outs. Distributors, and retailers are not agents of Eurolinx and are not authorized to bind Eurolinx by any express or implied undertaking or representation.

FOLLOW US ON:  [instagram.com/artusi_appliances](https://www.instagram.com/artusi_appliances)

 www.linkedin.com/company/eurolinx-pty-ltd-t-a-llve/

Australia National Telephone Number 1300 (694 583) New Zealand Telephone Number 64 3 344 5913
Artusi showroom hours: Tuesday to Friday - 9am-5pm, Saturday - 10am-4pm, Sunday and Monday - closed
* Melbourne showroom hours: Tuesday to Saturday - 10am-4pm

artusi.com.au

NSW & ACT (Head Office)
48-50 Moore Street
Leichhardt
F 02 8569 4699

VIC & SA
1211 Toorak Road
Camberwell
F 03 9809 2155

QLD
1/42 Cavendish Road
Coorparoo
F 07 3397 0850

New Zealand
PO Box 11,160
Sockburn Christchurch
F 03 344 5906

6KG FRONT LOAD DRYER

MODEL ACD60A

TECHNICAL DIAGRAM

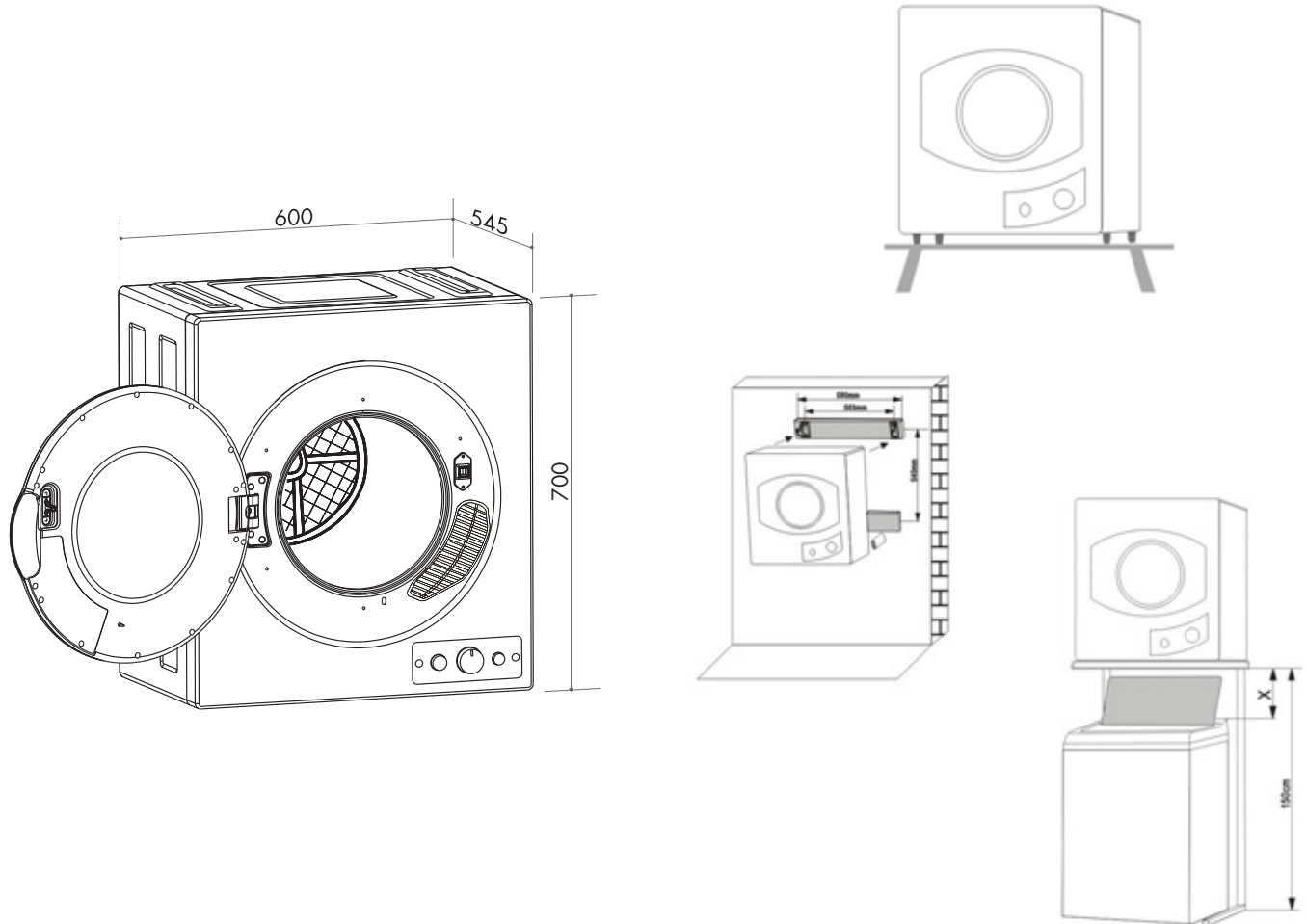

NB: drawings are not to scale — they are to be used for detailed installation instructions, please refer to user guide.

EAN 9347777001252

AR08042021

DISCLAIMER

Eurolinx PTY LTD, is continually seeking ways to improve the design specifications, aesthetics and production techniques of its products. As a result alterations to our products and designs take place continually. Whilst every effort is made to produce information and literature that is up to date, this brochure should not be regarded as an infallible guide to the current specifications, nor does it constitute an offer for the sale of any particular product. Product dimensions indicated in our literature is indicative only. Actual product only should be used to define dimension cut outs. Distributors, and retailers are not agents of Eurolinx and are not authorized to bind Eurolinx by any express or implied undertaking or representation.

ACD60A 6kg front-load dryer
Size mm 600W x 545D x 700H
drum dimensions: 560x304mm
220–240 V, 50Hz, 3-pin 10 amp plug
rated input power: 1500W

FOLLOW US ON:  [instagram.com/artusi_appliances](https://www.instagram.com/artusi_appliances)

 www.linkedin.com/company/eurolinx-pty-ltd-t-a-lve/

Australia National Telephone Number 1300 (694 583) New Zealand Telephone Number 64 3 344 5913
Artusi showroom hours: Tuesday to Friday - 9am-5pm, Saturday - 10am-4pm, Sunday and Monday - closed
*** Melbourne showroom hours:** Tuesday to Saturday - 10am-4pm

[artusi.com.au](https://www.artusi.com.au)

NSW & ACT (Head Office)
48-50 Moore Street
Leichhardt
F 02 8569 4699

VIC & SA
1211 Toorak Road
Camberwell
F 03 9809 2155

QLD
1/42 Cavendish Road
Coorparoo
F 07 3397 0850

New Zealand
PO Box 11.160
Sockburn Christchurch
F 03 344 5906