

TOURING ITEMS
TYPES

S402

4K Dual View Dashcam with 1080P Cabin Facing Cam

WP ITM. BT532872
Care & Use Instructions



**Important, retain for future reference:
Read carefully**

TABLE OF CONTENTS

1. Introduction	3
2. Package Contents	4
3. Product Specifications	5
4. Product Dimension	5
5. Product Overview	6
6. Button Configuration	7
7. Before You Start.....	8
8. Installation	8
9. Initial Setup	10
10. Menu Settings.....	11
11. Camera Status & LED Indicators	17
12. Recording Time	17
13. Time-lapse Recording Logic	18
14. Technical Specifications	18
15. Downloading and use the TYPE S Drive App	19
16. App Setup	20
17. App Settings	23
18. Viewing and Managing Media Files Using A Computer	26
19. Safety Information	27
20. Maintenance & Warranty	29
21. General Information	32

1. INTRODUCTION

Please read all of the installation instructions carefully before installing the product. Improper installation will void manufacturer's warranty. The installation instructions do not apply to all types of vehicles, and are written as guidelines to assist in installing the product.

Consult an experienced technician if you are not comfortable installing the product. You can also contact TYPE S at **866.294.9244** to speak to one of our installation specialists if you have any specific questions regarding the Dashcam.

BEFORE using the Dashcam, please read the safety information provided in this user manual. ALWAYS use the product as outlined in this user manual.

Please make sure to read and understand all local laws and regulations regarding cameras and their use in a vehicle. Laws vary by state.

2. PACKAGE CONTENTS

1. 1 x 4K Dual View Dashcam with 1080P Cabin Facing Cam
2. 1 x 12 / 24V Power Adapter
3. 1 x Windshield Mount
4. 1 x Mounting Bracket with 3M VHB™ Double-sided Tape
5. 1 x 3M VHB™ Double-sided Tape (Spare)
6. 1 x Static Sticker
7. 1 x 16GB MicroSD Card
8. 1 x 3.28' / 1m USB-A to USB-C File Transfer Cable
9. 1 x Instruction Manual
10. 1 x Warranty Card

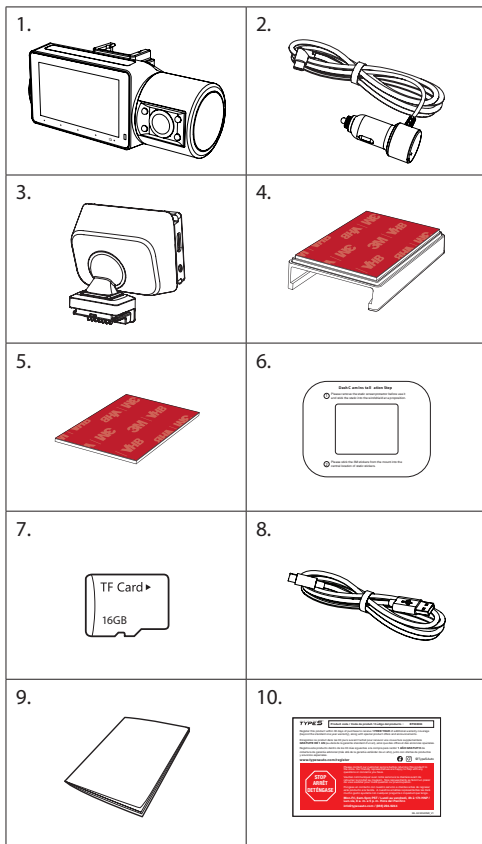

3. PRODUCT SPECIFICATIONS

Screen:	2.4" IPS
Resolution:	4K UHD - Ultra High Definition (3840 x 2160p)
Frequency:	2.4 GHz
Operating Voltage:	DC 12 / 24V - Cigarette Lighter Adapter (CLA)
Operating Temperature:	14°F~140°F (-10°C~60°C)
Viewing Angle:	139.4° (Front Camera), 132° (Cabin View Camera)
Image Sensor:	5MP
Maximum Signal Range:	9.84 Feet/3 Meters (without interference or obstruction)

4. PRODUCT DIMENSION

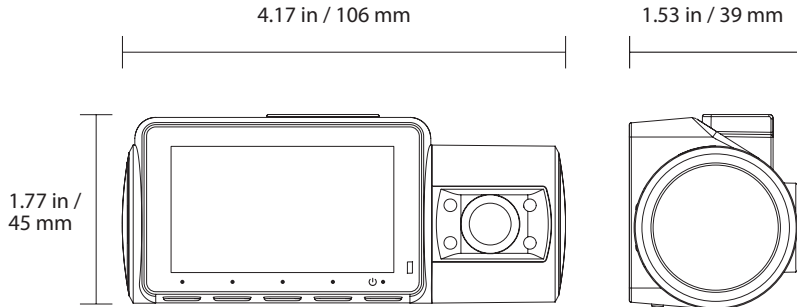

5. PRODUCT OVERVIEW

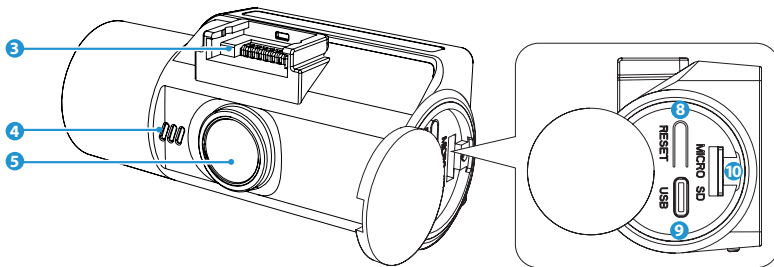
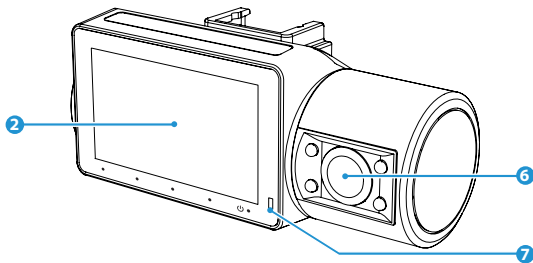
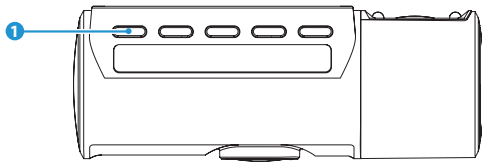

1. Function Buttons
2. Display Screen
3. Mounting Socket
4. Microphone
5. Front View Camera
6. Cabin View Camera
7. Status Indicator
8. Reset Button
9. USB-C Data Port
10. MicroSD Card Slot

6. BUTTON CONFIGURATION

Apply configuration and settings to the Dashcam using the 5 function buttons. Refer to the screen display below for the buttons and their corresponding functions in different modes.

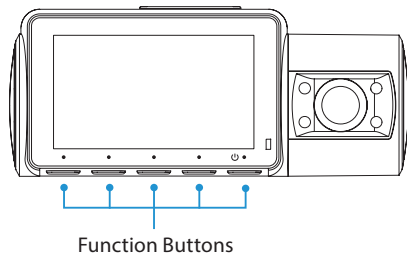

- ☰ Open Menu (click once)
- 3-in-1 Switch between Front/Cabin/Rear/3-in-1 view (click once)
- Snapshot (click once)
- ↶ Return to Video Mode (click once)
- ⏻ Screen On/Off (click once)
Power On/Off (press and hold for 3 sec)

- 🎤 Microphone On/Off (click once)
- 3-in-1 Switch between Front/Cabin/Rear/3-in-1 view (click once)
- 🔒 Lock/Unlock Video (click once)
- Record (click once)
- ⏻ Screen On/Off (click once)
Power On/Off (press and hold for 3 sec)

Note: Rear and 3-in-1 view only available when the 1080P Rear Camera (sold separately) is connected.

7. BEFORE YOU START

Before installing onto your vehicle, please test the product by powering it on and connecting it to the TYPE S Drive App (Section 16). Please use this document for detailed instructions and product information.

8. INSTALLATION

- 1 Peel off the protective film from the display screen.

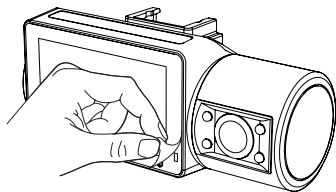

- 2 Insert the MicroSD card into the slot if not pre-installed.

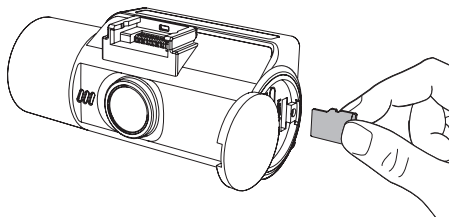

- 3 Attach the Dashcam to the Windshield Mount using the socket on the top.

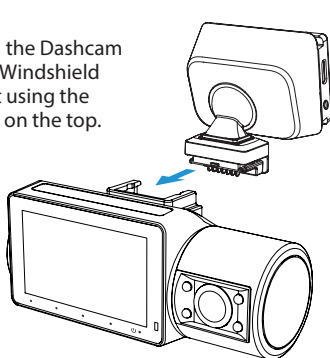

- 4 Plug the USB-C power cable into the input port on the Windshield Mount.



- 5 (Optional) Plug the 1080P Rear Camera power cable into the AV-IN port.

* 1080P Rear Camera (BT532838) sold separately.

- 6 Attach the Dashcam onto the windshield:
- Apply the static sticker onto the cleaned windshield and peel off the protective film.
 - Slide the Mounting Bracket into the Windshield Mount.
 - Peel off the 3M VHB™ tape backer from the mount and attach the Dashcam onto the static sticker.

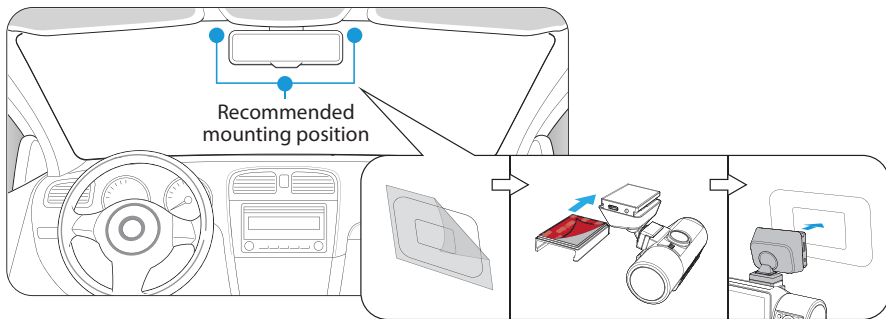

WARNING: When installing, please ensure that it won't obstruct the driver's field of vision.

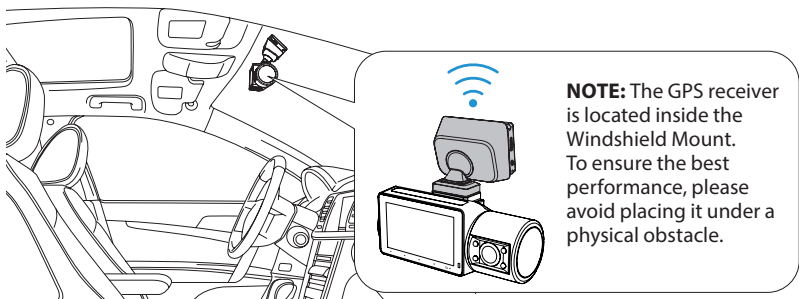

- 9 Adjust the Cabin View Camera's position to get the best view of the interior of your vehicle.

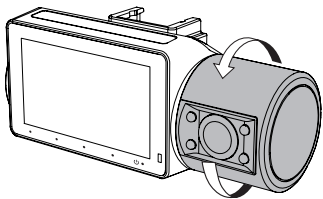

- 10 Route the power cable to your 12/24V outlet (cigarette lighter) and hide the cable in the headliner and pillars. We recommend going through the passenger side so the cable doesn't get into the driver's way.

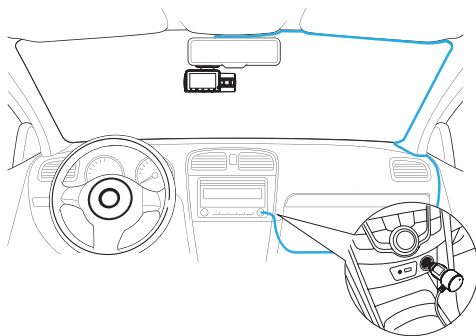

9. INITIAL SETUP

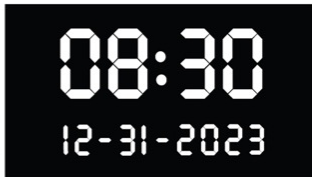
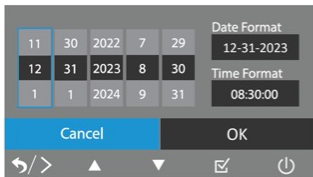



Set date & time. The date stamps that appear on all future recordings will follow this setting.

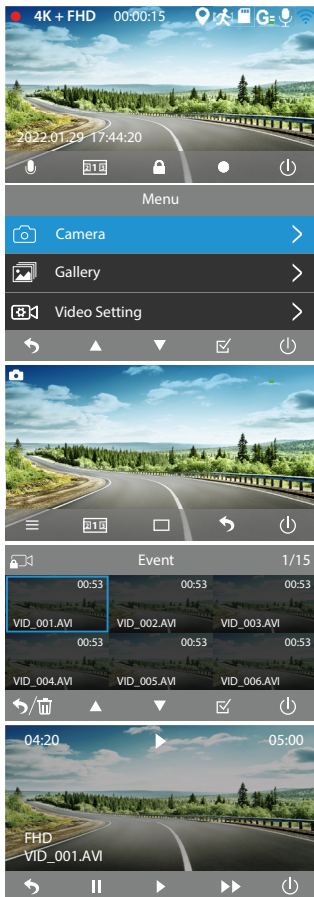

10. MENU SETTINGS







Video Mode

- The Dashcam will start recording automatically upon being connected to power.
- If you have connected an add-on 1080P Rear Camera (BT532838, sold separately), the display will default to 3-in-1 view.
- Click  to switch between front, cabin, rear and 3-in-1 view.
- Recording must be stopped manually to switch between modes. Click  to stop recording.





Camera Mode

- Click  to open menu and select Camera Mode.
- Click  to take a photo.
- Click  to return to Video Mode.

Gallery Mode

- Click  and select Gallery Mode in menu.
- Utilize  and  to cycle through Event, Video and Photo folders.
- Click  to enter the selected folder.
- In each folder, you can select between browsing from front and cabin view camera footages or photos. You may also browse rear camera footages and photos if you have the add-on 1080P Rear Camera (BT532838) connected.

Playback and manage files

- Utilize  and  to browse through the previews.
- Click  to play back the selected video file or enlarge the selected photo into full screen.
- Click  to adjust video speed to X2 or X4.
- Click  to return to the previews for next video.

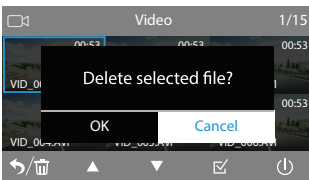
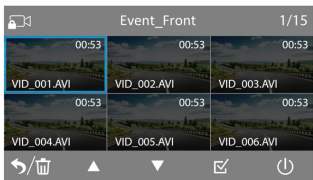

Erase Files

- In previews, click to delete the selected file or all files in the current folder.
- Click to confirm the erase.
- Press and hold to return to folder selection.

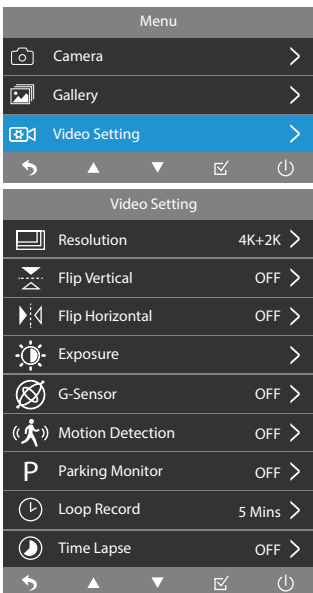

Video Setting

Resolution

- Switch between 4K+1080P and 2K+1080P resolution.
- You may also switch between 4K+1080P+1080P and 2K+1080P+1080P after pairing with the 1080P Rear Camera.

Flip Vertical

- Select to invert the rear camera image upside down.

Flip Horizontal

- Select to invert the rear camera image left to right.

NOTE: Flip Vertical and Flip Horizontal are only available when the add-on 1080P Rear Camera (BT532838) is connected.

Exposure

- Adjust the exposure level between +2.0, +1.0, 0, -1.0 and -2.0 for different lighting conditions.

G-Sensor

- Adjust the G-Sensor sensitivity between Off, High, Mid and Low.
- When the G-Sensor detects a sudden impact such as a collision, it'll automatically "lock" the footage and move it into the Events folder so that it doesn't get overwritten by the loop record feature.

Motion Detection

- Motion Detection On/Off. The Motion Detection function allows the Dashcam to start recording automatically when a moving object is detected. Please only use this function when the car is parked.

Parking Monitor

- Parking Monitor On/Off. The Parking Monitor function allows the Dashcam to record videos when an impact is detected while the vehicle's engine is off. The Dashcam will power on automatically and record a 20-second video clip then shut down.

NOTE: Feature only available when the Dashcam is hardwired to the fuse panel. Hardwiring kit (AC533513) sold separately.

Loop Record

- Select the duration of each recorded footage between 1 minute, 3 minutes and 5 minutes. Oldest and unlocked files will be overwritten once the storage limit is reached.

Time Lapse

- Select between normal video or time lapse video. (Refer to page 18).

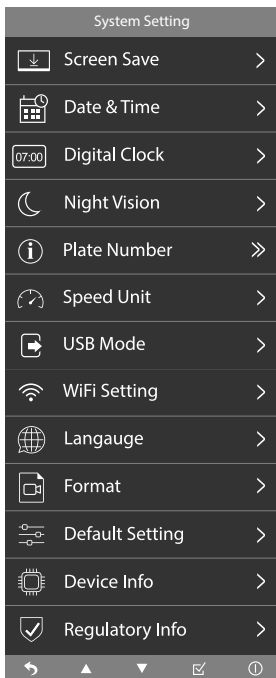
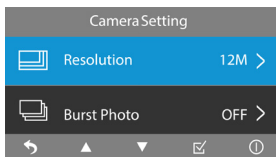

Camera Setting

Resolution

- Select photo resolution between 12M (4608 x 2592), 8M (3840 x 2160) and 5M (3072 x 1728).

Burst Photo

- Burst Photo On/Off. Burst Photo Mode allows you to capture a series of photos in quick succession.

System Setting

Screen Save

- Select the time of inactivity between Off, 1 minute, 3 minutes and 5 minutes. Screen will dim to a digital clock interface after the specified time of inactivity you select. To turn on the display, click any of the function buttons.

Date & Time

- Update the date & time shown on the Dashcam and on all its recorded media files.

Digital Cock

- Digital Clock (during screen save mode) On/Off. The digital clock and date will be shown on the screensaver when you set this as ON. Otherwise, the screen will be turned off.

Night Vision

- Set Night Vision to AUTO. Auto Mode will apply automatically under low-light conditions with brightened and color display.
- Set Night Vision to ON. Night Vision Mode will apply automatically under low-light conditions with brightened and black and white display.

NOTE: Night Vision function supported by Cabin View Camera only.

Plate Number

- When you have entered your license plate number and set this to ON, your plate number will show on all recorded media files alongside the date and TYPE S logo stamp.

Speed Unit

- Select the unit of speed between KM/H and MPH. Default speed unit is set as MPH.

USB Mode

- Select between Power On Only and Mass Storage mode.

NOTE: Refer to page 26 for accessing and managing files on a computer.

WiFi Setting

- The auto sync function enables you to view and manage files on your smart device using the TYPE S Drive App.

NOTE: Refer to page 19 for pairing procedure.

Language

- Default language of the Dashcam is English.

Format

- Erase all data on the MicroSD card.

Default Setting

- Reset settings to factory defaults.

Device Info

- Show the Dashcam's current firmware version.

Regulatory Info

- Show regulation related information.

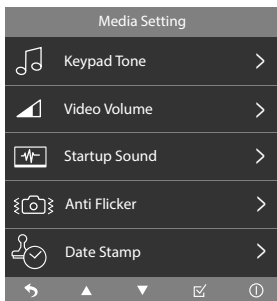

Media Setting

Keypad Tone

- Select to mute or unmute the keypad tone.

Video Volume

- Select the video volume of each recorded footage between Low, Mid and High.

Startup Sound

- Startup Sound On/Off. When you set this as ON, the Dashcam will play a tone upon being powered on.

Anti Flicker

- Adjust anti-flickering setting between 50Hz and 60Hz.

Date and TYPE S Logo Stamp

- Date and TYPE S Logo Stamp On/Off. When you set this as ON, the date and TYPE S logo stamp will show on all recorded media files.

11. CAMERA STATUS & LED INDICATORS

Power / Mode Status	LED Indicators
Power On Dashcam powers ON when the engine is turned on. To manually power ON, press and hold the power button for more than 3 seconds .	Red and Blue LED lights stay on when Dashcam is powering on.
Recording	Blue LED light flashes while Red LED light stays on.
Recording Stopped	Red and Blue LED lights stay on.

12. RECORDING TIME

Memory Card Capacity	Total Recording Time			
	(4K+1080)	(2K+1080P)	(4K+1080P+1080P)	(2K+1080P+1080P)
16GB	At least 48 mins	At least 65 mins	At least 80 mins	At least 114 mins
32GB	At least 140 mins	At least 159 mins	At least 183 mins	At least 260 mins
64GB	At least 320 mins	At least 366 mins	At least 355 mins	At least 500 mins
128GB	At least 600 mins	At least 700 mins	At least 500 mins	At least 560 mins

Note: If you use your own MicroSD card please insert it into the Dashcam and format it before first use.

13. TIME-LAPSE RECORDING LOGIC

Mode	Behavior
Off	Without time-lapse record, captures 30 frames per 1 second.
1 Second	Time-lapse record, captures 1 frame per 1 second.
3 Seconds	Time-lapse record, captures 1 frame per 3 seconds.
5 Seconds	Time-lapse record, captures 1 frame per 5 seconds.

14. TECHNICAL SPECIFICATIONS

Memory Management

Mode	Behavior	1-Minute Video Size	Loop Period (16GB SD Card)
4K + 1080P	3840 x 2160 + 1920 x 1080	190MB	9164 / 190 = 48 Minutes
2K + 1080P	2560 x 1440 + 1920 x 1080	140MB	9164 / 140 = 65 Minutes
4K + 1080P + 1080P	3840 x 2160 + 1920 x 1080 + 1920 x 1080	300MB	9164 / 300 = 30 Minutes
2K + 1080P + 1080P	2560 x 1440 + 1920 x 1080 + 1920 x 1080	210MB	9164 / 210 = 43 Minutes

Memory Card Capacity	Usable Space	System Reserve	Event & Video	Photo
16GB	14.75GB	4.8GB	8.95GB	1GB
32GB	29.11GB	4.8GB	23.3GB	1GB
64GB	59.44GB	4.8GB	53.6GB	1GB
128GB	110GB	4.8GB	104.2GB	1GB

15. DOWNLOADING AND USE THE TYPE S DRIVE APP

The Dashcam's auto sync function enables you to control and play back recorded media files using your smartphone with the TYPE S Drive App. Scan below QR code or search "TYPE S Drive" in the App Store or Google Play. Download and install the App.



SSID:
TYPE_S_DVR11_4K_xxxxxx

Password:
12345678



Compatible with iPhone 4s and higher, iPad3, iPad Mini, iPad Air and higher, and iPod touch 5th Generation and higher. Requires iOS 9.0 or higher.



Compatible with phones with Android™ 5.0 or higher.

Once installed, open the APP and begin enjoying your TYPE S Drive APP.

NOTE: The APP is only available on smartphones with Apple iOS 9 or newer, and Android 5.0 or newer. The TYPE S Drive App is not accessible from tablets, browsers, or PCs.

16. APP SETUP

Auto sync with the Dashcam

1. Open the Dashcam's menu and navigate to **System Setting**.
2. Go to WiFi Setting and turn it on.

NOTE: WiFi is ON by default.

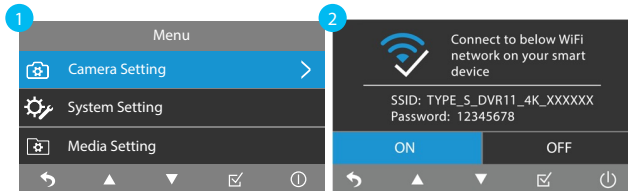

Android device

3. Navigate to the WiFi setting page on your device.
4. Connect to "TYPE_S_DVR11_4K_XXXXXX" with the default password "12345678".
5. Run the TYPE S Drive App. Click **Allow** in the pop-up message when prompted to allow the App to access your location
6. Select the **Dash Camera** category.
7. Scroll down the device list and select S402 PRO & S402 DASH CAM. Click **Set Up Device**.
8. You should see the live view of Dashcam on the main interface if the connection is successful.
NOTE: After the initial sync, the App remembers your Dashcam's network so that you can simply click **Connect** to rejoin next time.

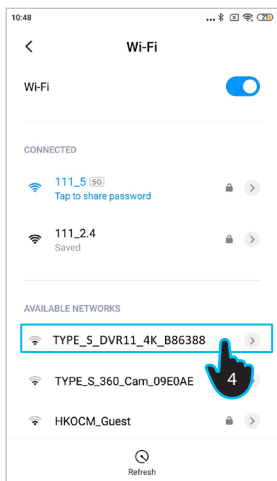
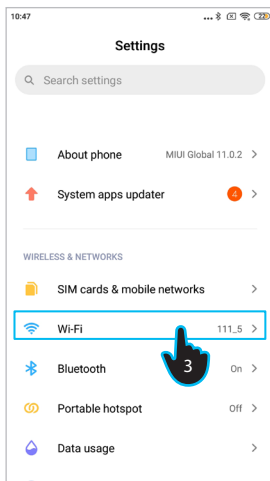

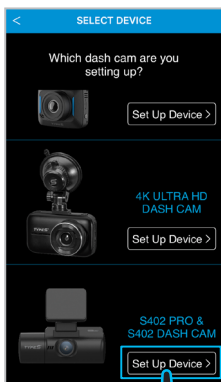
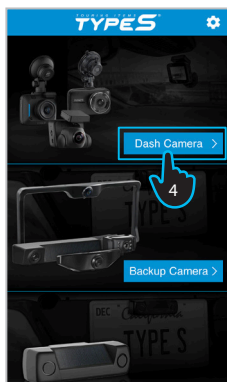
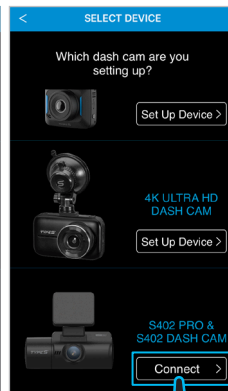
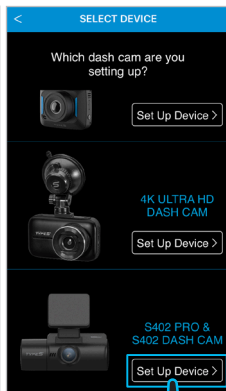
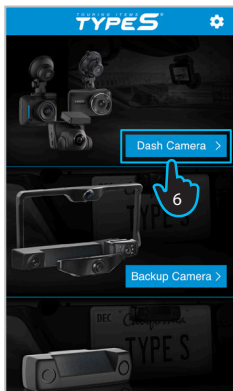
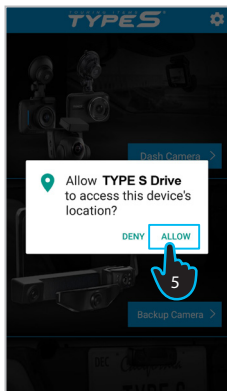

iOS device

(Follow steps 1 - 2 from previous page's instructions)

3. Please make sure Bluetooth, Location Services and Local Network Access are enabled on your device.
4. Run the TYPE S Drive App and select the **Dash Camera** category.
5. Scroll down the device list and select S402 PRO & S402 DASH CAM. Click **Set Up Device**.

- Click **Join** in the pop-up message if prompted to connect to the Dashcam's WiFi network. OR Click  to go to App permissions setting page.
- Click **Settings** on the App permissions setting page.
- Scroll to the top and click to enter the WiFi setting page.
- Connect to "TYPE_S_DVR11_4K_XXXXX" with the password "12345678".
- Click **TYPE S Drive** to return to the App.
- Once connected, you will be able to see the Dashcam's real-time view through the App.

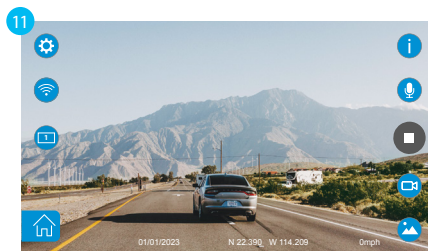
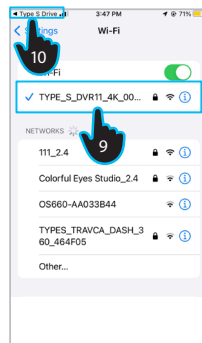
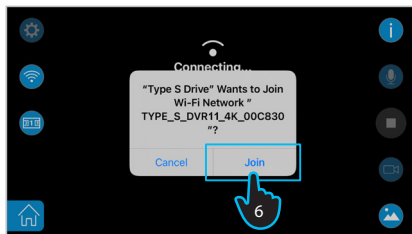

17. APP SETTINGS



Display Mode

Select from 5 different viewing modes.

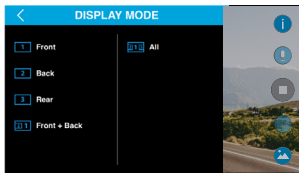

1 Front



2 Back



3 Rear



2+1 Front + Back



3+1+0 All

NOTE: "Rear" mode and "All" mode only available when the add-on 1080P Rear Cam (BT532838) is connected.

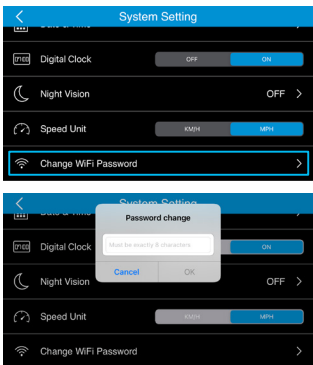

Change WiFi Password

Click  to open Main Menu, then navigate to System Setting > Change WiFi Password. Enter your preferred password (must be exactly 8 characters), then click **OK** for changes to effect. Connect to your Dashcam's WiFi network again with the revised password.

Note: It is recommended to reset your WiFi password upon initial connection to protect your data from unauthorized access.

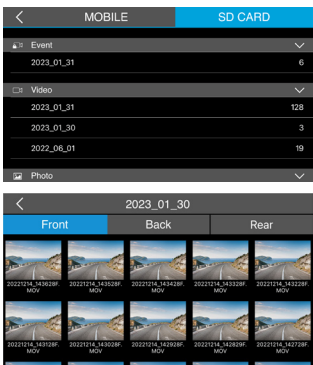



Gallery

Click  on the main interface to enter the media gallery. Click **SD CARD** to access all media files sorted from latest to oldest in the MicroSD card. Scroll down the list to select the file.

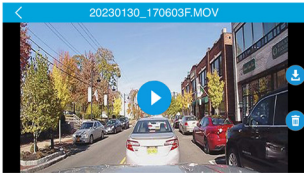
In each file, you can browse between front and cabin view camera footages and photos. Rear camera footages and photos are also available after pairing with the 1080P Rear Camera.



SD CARD

Click  to download the selected file onto your smart device or  to delete the file from the MicroSD card.

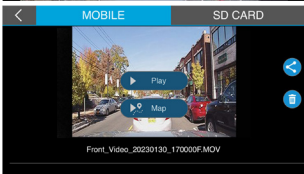



MOBILE

Click **MOBILE** to access and manage the downloaded file on your smart device even if it is disconnected from the Dashcam.

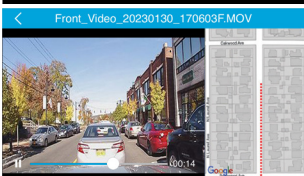
Click  to share or  to delete the selected file.



GPS Information

Click  **Play** to play the footage or  **Map** to view embedded GPS location simultaneously during playback.

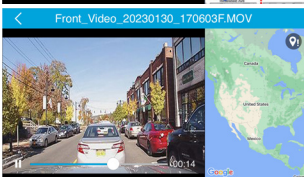

GPS Signal Status 1

GPS receiver is searching for GPS signal when the footage is recorded. GPS trip data will resume once it picks up the signal. If this status persists, please contact our technical support for troubleshooting.

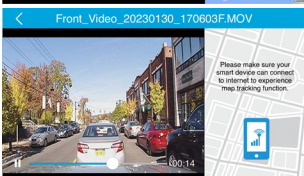

GPS Signal Status 2

Map tracking is not working. To process, mobile data must be turned on.

18. VIEWING AND MANAGING MEDIA FILES USING A COMPUTER

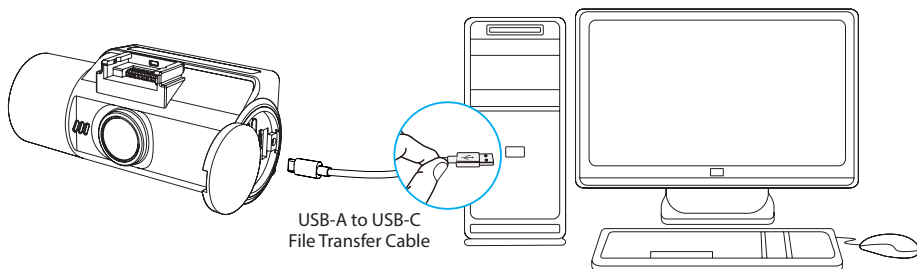

When connected directly to a computer via the cable provided, the Dashcam will default into charging mode. To view/manage files in the MicroSD card, please go to menu > System Setting > USB Mode and switch the Dashcam to Mass Storage mode. The screen below will show up. The Dashcam will function as a card reader for the computer, and it will appear as a new USB drive.

Note: The Dashcam will stop recording when it is connected to a computer.

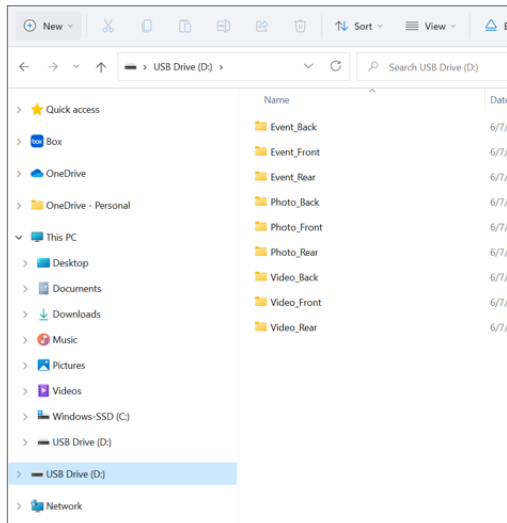

19. SAFETY INFORMATION

IMPORTANT SAFETY INSTRUCTIONS

1. SAVE THESE INSTRUCTIONS– This manual contains important safety and operating instructions of 12 / 24V Car charger for Model BT532872.
2. Before using the product, read all instructions and cautionary markings.
3. Do not expose car charger to rain, moisture, or snow.
4. Use of an attachment not recommended or sold by the product manufacturer may result in a risk of fire, electric shock, or injury to persons.
5. To reduce risk of damage to cigarette lighter connector and cord, pull by cigarette lighter connector rather than cord when disconnecting car charger.
6. Make sure the cord is located so that it will not be stepped on, tripped over, or otherwise subjected to damage or stress.
7. Do not operate the car charger with a damaged cord or cigarette lighter connector – replace the damaged items with new factory replacement items immediately.
8. Do not operate the car charger if it has received a sharp blow, been dropped, or otherwise damaged in any way; take it to a qualified serviceperson.
9. Do not disassemble the car charger; take it to a qualified serviceperson when service or repair is required. Incorrect reassembly may result in a risk of electric shock or fire.
10. To reduce risk of electric shock, unplug the charger before attempting any maintenance or cleaning. Turning off controls will not reduce this risk.

WARNING: A failure to read and follow these warnings and instructions may result in a serious accident, including damaged property or a serious injury, including loss of life.

- The Dashcam is designed as an aid to the driver in detecting large stationary objects to help avoid damaging the vehicle. However, you, the driver, must use it safely and properly. Use of the Dashcam is not a substitute for safe, proper and legal driving.
- Never depend on the Dashcam and Rear Cam (not included) entirely when driving and backing up. The image on the screen is different from actual conditions. Objects viewed in the Dashcam display screen differ from actual distance because a wide-angle lens is used.
- The Dashcam “Night Vision” feature that is high performance brightness with colorful image is an aid to a driver but is limited. Always use your eye to confirm the vehicle’s surroundings, as the displayed image may be faint or dark, distorted, or not entirely visible. Always check behind and

all around the vehicle visually with mirrors before proceeding.

- If you use Rear Camera (Not included), never back up while looking only at the screen. You should always check behind and around the vehicle when backing up just as you would if the vehicle did not have the Rear Camera. Always make sure your intended path is clear. If you back up while looking only at the monitor, you may hit a vehicle, pedestrian, bicyclist, child, pet or other object resulting in injury or death. Always back up slowly.
- The area displayed by the Dashcam and Rear Cam (not included) is limited. The Dashcam does not display objects that are out of the Dashcam's field of view. The Rear Cam (not included) does not display objects that are close to or below the bumper, underneath the vehicle, or objects out of the camera's field of view. The area displayed on the screen may vary according to vehicle orientation or road conditions.
- Be sure to check the Dashcam's position and mounting angle before each use.
- Do not strike the Dashcam. It is a precision instrument. Otherwise, it may malfunction or cause damage resulting in a fire or an electric shock.
- This product will only provide images of items that are within the field of view of the Dashcam. Thus, it is imperative that the Dashcam should be kept clean and unobstructed.
- Adhere to all applicable traffic laws and motor vehicle regulations applicable to the device.
- Consult local laws and regulations for any restrictions on installation or use.
- Never allow children to play with the device. Small parts may be a choking hazard.
- There is a plastic cover over the Dashcam. Do not scratch the cover when cleaning dirt or snow from the cover.
- If the temperature changes rapidly, the system may not operate normally.
- If you replace the tires, the area displayed on the monitor may change and you may need to adjust the camera.
- When strong light directly enters a Dashcam, objects may not be displayed clearly.
- The screen may flicker under fluorescent light.
- The colors of objects on the Dashcam may differ from those of the actual objects.
- Do not use alcohol or thinner to clean the Dashcam. This will cause discoloration. To clean the Dashcam, wipe with a clean cloth dampened with mild cleaner diluted with water and then wipe with a dry cloth.

SAFETY AROUND AND BEHIND OTHER VEHICLES

Many preventable injuries and deaths occur in driveways or parking lots when drivers do not see children, pets, or others near their vehicles. Here are a few safety tips that will help you to avoid a back-over accident:

- Walk completely around your vehicle before getting in. Check for kids, toys, and pets before entering the vehicle and starting the engine.
- Know where children are. Have children stand in a place where they are in full view.
- Be aware of young children. Young children are small and hard to see.
- Parents, caregivers and all adults need to be vigilant in supervising children, especially when children are in the yard, driveway or parking lot playing near parked cars.
- Roll down your window so you will be able to hear what is happening outside your vehicle.
- Owners of SUVs, trucks, and vans need to take extra care to avoid hitting or running over a child.
- Teach children to move away from a vehicle whenever it is started.

20. MAINTENANCE & WARRANTY

CLEANING

- If dirt, rain or snow attaches to the camera, the display screen may not clearly display objects. If water droplets, snow or mud adhere to the camera lens, rinse with water and wipe with a dry cloth.
- Do not use alcohol, benzene or thinner to clean the Dashcam. This will cause discoloration. To clean the Dashcam, wipe with a clean cloth dampened with mild cleaner diluted with water and then wipe with a dry cloth.

WARRANTY

- **TYPE S
LIMITED WARRANTY**

TYPE S warrants, to the original purchaser, that its products are free from defects in material and workmanship for 1 year from the date of original purchase. Where permitted by law, TYPE S liability shall be limited to that set forth in this limited express warranty. This limited express

warranty shall be the exclusive remedy of the purchaser and TYPE S makes no other warranty of any kind aside from the limited express warranty stated above.

NOTE: Warranty only applies for North American customers of purchases made in North America.

CONDITIONS OF WARRANTY

If during the 1 year warranty period your new product is found to be defective, TYPE S will repair such defect, or replace the product, without charge for parts or labor subject to the following conditions:

1. All repairs must be performed by TYPE S.
2. All warranty claims must be accompanied by a copy of the sales receipt or bill of sale.
3. The equipment must not have been altered or damaged through negligence, accident, improper operation, or failure to follow the product instructions for installation, use, or care.
4. The replacement of parts is excluded from the warranty when replacement is necessary due to normal wear and tear.
5. Repair or replacement parts supplied by TYPE S under this warranty are protected only for the unexpired portion of the original warranty.
6. This is a "repair or replace" warranty only, and does not cover the costs incurred for the installation, removal or reinstallation of the product, or damage to any mobile phone device or vehicle.

OWNER'S RESPONSIBILITIES:

TYPE S will make every effort to provide warranty service within a reasonable period of time. SHOULD YOU HAVE ANY QUESTIONS ABOUT SERVICE RECEIVED OR IF YOU WOULD LIKE ASSISTANCE IN OBTAINING SERVICE, PLEASE CALL TOLL FREE 1.866.294.9244 DURING REGULAR BUSINESS HOURS MONDAY THROUGH FRIDAY 8:00 AM TO 5:00 PM.

NOTE: Toll Free # is for North America Customers ONLY. See Customer service section for customer contact numbers for other regions/offices.

For customer service and technical support, please call us at 1.866.294.9244. If at that time it is determined that a replacement unit is needed, the support representative will issue a Return Authorization and instruct on how to get a new unit. TYPE S makes no other warranty of any kind aside from the limited express warranty stated herein.

DISCLAIMER OF WARRANTIES, INCLUDING WARRANTY OF MERCHANTABILITY AND WARRANTY OF FITNESS FOR PARTICULAR PURPOSE: EXCEPT AS SPECIFICALLY SET FORTH HEREIN, NO WARRANTY OR REPRESENTATION, EXPRESS OR IMPLIED, IS MADE AS TO THE Dashcam. EXCEPT AS EXPRESSLY SET FORTH HEREIN, TYPE S AND/OR ITS AFFILIATES EXPRESSLY DISCLAIMS, WITHOUT LIMITATION, ANY STATUTORY WARRANTIES AND ALL IMPLIED WARRANTIES, INCLUDING ANY IMPLIED WARRANTY OF MERCHANTABILITY OR FITNESS FOR A PARTICULAR PURPOSE.

TYPE S and/or its affiliates do not guarantee or promise that the user of Dashcam will not be in an accident or otherwise not collide with an object and/or person. Our Dashcam is not intended in any way to be a substitute for careful and cautious driving or for the consistent adherence to all applicable traffic laws and motor vehicle safety regulations.

The Dashcam is not intended to be a substitute for rearview mirrors or for any other motor vehicle equipment mandated by law. Even when properly installed, our Dashcam has a limited field of vision and does not provide a comprehensive view of the rear area of the vehicle.

TYPE S and/or its affiliates are not responsible for a user's intended or actual use of the Dashcam. In no event shall TYPE S and/or its affiliates have any liability for any losses (whether direct or indirect, in contract, tort or otherwise) incurred in connection with the Dashcam, including but not limited to damaged property, personal injury and/or loss of life. Neither shall TYPE S and/or its affiliates have any liability for any decision, action or inaction taken by any person in reliance on the Dashcam, or for any delays, inaccuracies and /or errors in connection with the Dashcam and its functioning.

TYPE S and/or its affiliates are not responsible for a user's intended or actual use of the Dashcam. In no event shall TYPE S and/or its affiliates have any liability for any losses (whether direct or

indirect, in contract, tort or otherwise) incurred in connection with the Dashcam, including but not limited to damaged property, personal injury and/or loss of life. Neither shall TYPE S and/or its affiliates have any liability for any decision, action or inaction taken by any person in reliance on the Dashcam, or for any delays, inaccuracies and /or errors in connection with the Dashcam and its functioning.

TYPE S and/or its affiliates shall have no responsibility or liability for damage and/or injury resulting from accidents occurring with vehicles having the installed, and TYPE S and/or its affiliates, the manufacturer, distributor and seller shall not be liable for any injury, loss or damage, incidental or consequential, arising out of the use or intended use of the product.

21. GENERAL INFORMATION

CUSTOMER SERVICE/CONTACT

IF YOU ARE EXPERIENCING ANY ISSUES WITH THE PRODUCT DURING OPERATION, DO NOT RETURN THE PRODUCT TO THE STORE. CONTACT TYPE S DIRECTLY FOR INSTRUCTIONS ON HOW TO RETURN/ EXCHANGE THE PRODUCT.

FCC Compliance Statement:

This device complies with Part 15 of the FCC rules. Operation is subject to the following two conditions: (1) This device may not cause harmful interference, and (2) this device must accept any interference received, including interference that may cause undesired operation.

WARNING: Changes or modifications to this unit not expressly approved by the party responsible for compliance could void the user's authority to operate the equipment. The manufacturer is not responsible for any radio or TV interference caused by unauthorized modifications or change to this equipment. Such modifications or change could void the user's authority to operate the equipment.

NOTE: This equipment has been tested and found to comply with the limits for a Class B digital device, pursuant to part 15 of the FCC Rules. These limits are designed to provide reasonable protection against harmful interference in a residential installation. This equipment generates uses and can radiate radio frequency energy and, if not installed and used in accordance with the instructions, may cause harmful interference to radio communications. However, there is no guarantee that interference will not occur in a particular installation. If this equipment does cause harmful interference to radio or television reception, which can be determined by turning the equipment off and on, the user is encouraged to try to correct the interference by one or more of the following measures:

- Reorient or relocate the receiving antenna.
- Increase the separation between the equipment and receiver.
- Connect the equipment into an outlet on a circuit different from that to which the receiver is connected.
- Consult the dealer or an experienced radio/TV technician for help.

This equipment complies with FCC RF radiation exposure limits set forth for an uncontrolled environment. In order to avoid the possibility of exceeding the FCC radio frequency exposure limits, human proximity to the antenna shall not be less than 20cm during normal operation.

S402

4K Dual View Dashcam with 1080P Cabin Facing Cam

BT532872

Responsible Party:

TYPE S

2975 Red Hill Ave., Ste. 100,
Costa Mesa, CA 92626, U.S.A.

Tel: 1-866-294-9244

Android is a trademark of Google Inc.

iPhone, iPad, Mac and iPod touch are trademarks of Apple Inc.

3M VHB™ is a trademark of 3M Company.



A Horizon Brands Company

2975 Red Hill Ave., Ste. 100, Costa Mesa, CA 92626, U.S.A.

1.866.294.9244 | info@typesauto.com

©2023 TYPE S. All rights reserved.

www.typesauto.com

ML-532872E_V1