



aobosi

Instruction Manual

Slow Juicer

Brand:A aobosi

Model:ZM1507A

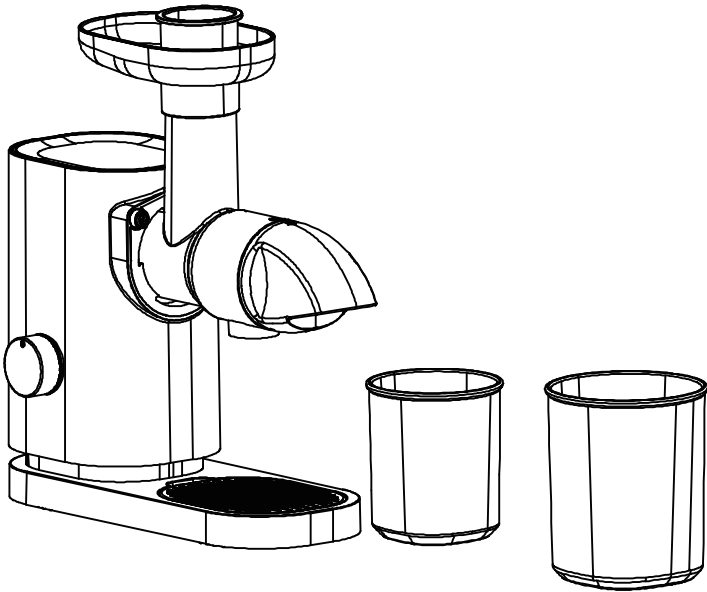

**PLEASE READ INSTRUCTIONS CAREFULLY BEFORE ASSEMBLY
RETAIN THIS MANUAL FOR FUTURE REFERENCE**

Content

Section 1 Precautions for Safety Use.....	1
Section 2. Operating Instructions.....	4
Section 3. Quick Start Assembly.....	5
Section 4. Installation Notes.....	6
Section 5. Tips for Ingredients Selection.....	7
Section 6. Maintenance.....	8
Section 7. Only Hand Wash & Easy Cleaning.....	10
Section 8. Safety Index.....	11
Section 9.Warranty.....	12
Section 10. Troubleshooting.....	13

Section I. Precautions for Safety Use

All users of this appliance must read and understand these safety precautions before operating.

SIGN SAMPLES



This sign indicates contents that may cause risk of a fire or an electrical shock.

Specific warnings are written in the sign.



This sign indicates contents of regulating or directing actions.

Specific prohibitions are written around or in the sign.



This sign indicates prohibited acts.

Specific prohibitions are written around or in the sign.

PRECAUTIONS FOR SAFE USE



1. DO NOT PLUG IN OR UNPLUG WITH WET HANDS.

It may cause an electric shock or an injury.



2. DO NOT USE WITH OTHER THAN RATED VOLTAGE.

It may cause an electric shock, a fire or abnormal performance. If the voltage is different, it may shorten the life of the motor or cause a failure.



3. PLUG THE POWER CORD CORRECTLY AND PUSH IT TIGHT IN A WALL SOCKET.

It may cause electric shock or a fire.



4. IF THE SUPPLY CORD IS DAMAGED, IT MUST BE REPLACED BY THE MANUFACTURER, ITS SERVICE OR SIMILARLY QUALIFIED PERSONS IN ORDER TO AVOID A HAZARD.

If the power cord is damaged, it may cause electric shock or a fire.



5. NEVER ALTER THE APPLIANCE. ALSO, DO NOT DISASSEMBLE OR REPAIR BY YOURSELF. DO NOT INSERT FINGERS, FOREIGN SUBSTANCES OR OBJECTS SUCH AS PINS INTO GAPS OR HOLES IN THE BASE.

It may cause a fire, an electric shock or a failure. For any technical support, contact the authorized local Customer Care Center.



6. DO NOT MOISTEN THE BASE OR SPLASH WATER ON THE BASE.

Be careful not to let any liquids or other substances get into the switch on the appliance. DO NOT OPERATE THE SWITCH WITH WET HANDS. It may Cause electric shock or a fire.



7. WHEN THE POWER CORD, WIRE IS BROKEN OR DAMAGED OR THE PLUG-IN PART BECOMES LOOSE, DO NOT OPERATE IT.

It may cause an electric shock, a fire or an injury



8. FOR SAFETY, MUST DO GROUND CONNECTION DO NOT DO THE GROUNDING ON GAS PIPE, PLASTIC WATER PIPE, TELEPHONE WIRE, ETC.

It could cause an electric shock, a fire, or a malfunction and an explosion. Be sure to use the socket with ground connection.



9. NEVER DISASSEMBLE BOWL SET DURING OPERATION OR INSERT FINGERS, FOREIGN OBJECTS SUCH AS FORKS, SPOONS ETC. INTO FEEDING TUBE OR JUICE OUTLET.

It may cause an injury, an accident or a failure. Never replace the spiral pusher with any other objects or have eyes get close to the feed port, otherwise accidents may happen.

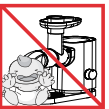

10. THIS APPLIANCE IS NOT INTENDED FOR USE BY PERSONS INCLUDING CHILDREN) WITH REDUCED PHYSICAL, SENSORY OR MENTAL CAPABILITIES, OR LACK OF EXPERIENCE AND KNOWLEDGE, UNLESS THEY HAVE BEEN GIVEN SUPERVISION OR INSTRUCTION CONCERNING USE OF THE APPLIANCE BY A PERSON RESPONSIBLE FOR THEIR SAFETY.

Children should be supervised to ensure that they do not play with the appliance. Children are not allowed to clean and perform user maintenance without supervision.



11. DO NOT OPERATE WITHOUT LOCKING THE HOPPER PROPERLY.

It may cause an injury or a failure.



12. IF A GAS LEAK IS DETECTED, DO NOT PLUG IN THE APPLIANCE'S POWER CORD INTO A POWER OUTLET IMMEDIATELY VENTILATE THE ROOM BY OPENING A WINDOW, AND ALLOW TO FULLY VENTILATE BEFORE PLUGGING IN THE APPLIANCE.

It may cause an injury or a failure.



13. IF SCREW ROTATION IS STOPPED IN NORMAL OPERATION, PRESS IRI BUTTON AND HOLD FOR 3 SECONDS AND THEN AFTER REVERSE OPERATION IS COMPLETELY STOPPED, PRESS IONI BUTTON AGAIN.

If such a stop event continues during the operation, the parts may be damaged and performance may be deteriorated due to overheating in a motor. When the problem continues, immediately stop the appliance and contact the local Customer Care Center.



14. CAUTION

1. Before use, please check if the power cord, the plug, the juice strainer, the spiral pusher and any other part is damaged. If any of the said part is damaged, stop using the appliance and contact our customer service department promptly. Do not dismantle and repair it by yourself, otherwise dangers may happen.
2. It is necessary before connecting the power supply to ensure that the juicing body, the spiral pusher, the juicing body cap and all other dismantlable parts are properly installed.
3. Cut food ingredients into small blocks with sizes fitting the feed port of the juicing body. Do not begin to process any vegetables or fruits with cores, hard seeds or thick skin or shells until the cores, hard seeds or thick skin or shells are removed.
4. When feeding a food ingredient, do not make the pushing force too large but have it just enough to cut the food ingredient.
5. Dyeing of the juice strainer, the juicing body cap, the spiral pusher and other accessories after juicing of some vegetables or fruits is normal and will neither affect food eating nor do harm to health.
6. If the appliance has current limiting protection or its motor is locked and stops automatically and cannot reverse automatically, switch off the power switch and put it on the "o" position, then press the "ON" button of the power switch to discharge the food ingredients in the appliance and finally press the "R" button of the power switch for normal use of the appliance. If the motor is still locked, it is suggested to remove the food ingredients in the spiral pusher before continue to use the appliance. This measure can protect the motor.
7. Do not dismantle the dismantlable parts of the appliance immediately after use but after both the motor and the spiral pusher have stopped and the power supply is disconnected.
8. Do not sterilize any accessories of the appliance with hot water with a temperature higher than 80 °C or a microwave oven, otherwise they may heated, deformed and damaged. The materials of all parts in contact with food ingredients should comply with food hygiene certification and be clean, hygienic and reliable.
9. Do not clean the appliance with steel wool, abrasive cleaning agents or corrosive liquids (such as gasoline or acetone).
10. The appliance is applicable to use by individuals or families only.
1. Accessories, other than those supplied with the appliance, include instructions for their safe use.
12. Switch off the appliance and disconnect from supply before changing accessories or approaching parts that move in use.
13. Hazards or unsafe practices could result in minor personal injury or appliance damage. Care shall be taken when handling the sharp cutting blades, emptying the bowl and during cleaning. Always disconnect the appliance from the supply if it is left unattended and before assembling, disassembling or cleaning.

Section 2. Operating Instructions

JUICING FUNCTION

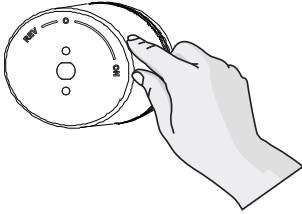
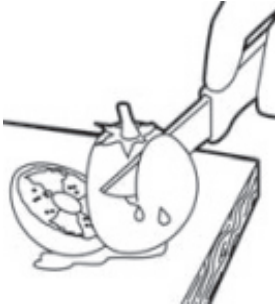
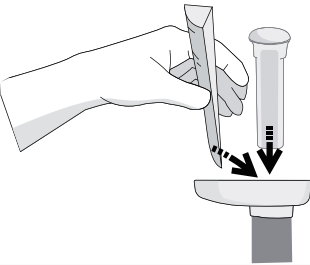
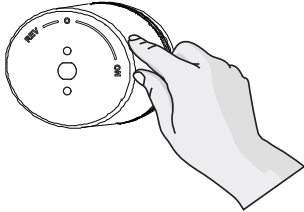
	<p>1. Press [ON] button of the A aobosi Juicer to start.</p> <p>Tips : In case of Pulp blockage or motor locking. Press and hold "REV" button for approximately 3 seconds to rotate the auger reversely and then release it. Press "ON" button to resume normal operation.</p>
	<p>2. Clean the material and cut it into pieces small sufficiently which can pass through the Feed chute, and place them onto the tray.</p> <p>Note: Any hard core, seed, skin or shell from fruits and vegetables shall be removed in advance.</p>
	<p>3. Gradually put the ingredients into the hopper chute and press down with the pusher. Press [ON] button of the A aobosi Juicer to start.</p> <p>Note: DO NOT place any metal objects into.</p>
	<p>4. After the extraction or processing is complete, place the switch in the stop position to stop.</p> <p>⚠ Warning: When using [ON] or Rev] button, make sure that the auger stops completely.</p>

Section 3. Quick Start Assembly

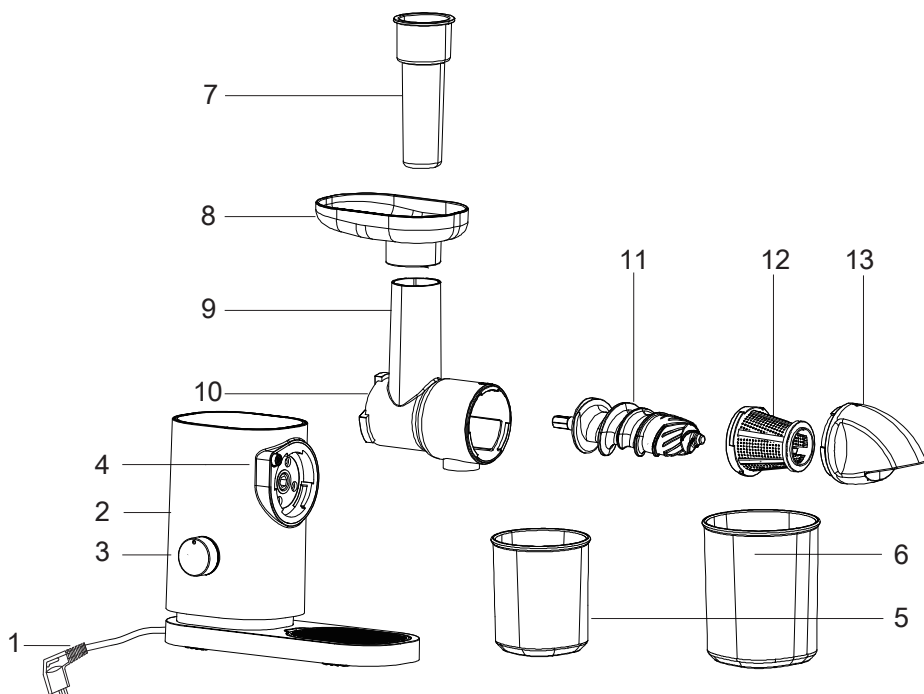

1.Power Cable

2.Motor Base

3.On-Off Switch

4.Locking Button

5.Juice Container

6.Pulp Container

7.Food Pusher

8.Hopper

9.Feed Chute

10.Drum

11.Auger

12.Juicer Screen

13.End Cap

Section 4. Installation Notes

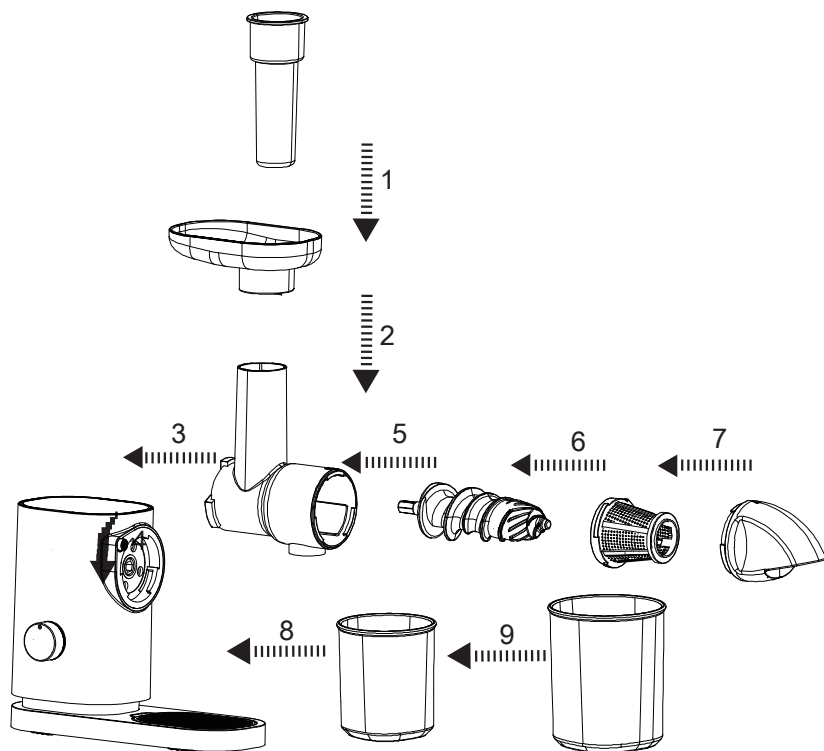

- 1.Place the food pusher(7) onto the feeder chute (9) .
- 2.Place the hopper (8) onto the feeder chute (9) .
- 3.Install the drum (10) to the motor base (2).
- 4.Push and rotate anticlockwise.
- 5.Push the auger (11) into the drum (10).
- 6.Insert the juicer screen (12).
- 7.Place the end cap (13) and screw it anticlockwise.
- 8.Place the juice container (5) under the drum (10).
- 9.Place the pulp container (6) under the end cap (13).

Section 5. Tips for Ingredients Selection

FRUIT JUICE EXTRACTOR

Efficiently juices hard and soft fruits: even citrus fruits, usually one of the hardest fruits to juice.

Jam can not be achieved, some fruit can not squeeze juice (such as bananas, mangoes, dried fruit, sugar cane, etc.).

VEGETABLE JUICE

Cut vegetables to strips(less than 10 cm).

Juices all kinds of vegetables including carrots, beets, celery, peppers, and radishes without destroying the natural flavor and nutrition benefits. Fresh taste and full nutrition are guaranteed with this unique extraction process.

WHEATGRASS AND LEAFY GREENS

Cut it to strips(less than 10 cm).

Wheat grass, kale, cabbage, spinach and pine tree needles are just some of the natural products that can be juiced with the juicer. Enjoy the best that nature offers in raw foods of all kinds and juice them for full nutritional benefits.

Instructions on Selection of Fruits

1. Select fresh fruits and vegetables, which contain more juice. The proper fruits include: pineapple, beet root, celery stalk, apple, cucumber, spinach, melons, tomato, orange and grape.

2. Thick skin on fruits such as orange, pineapple and raw beet root instead of thin skin on fruit/vegetable needs to be removed. Seeds in oranges should be removed as well, which may make the juice taste a little bitter.

3. Just extracted apple juice will turn brown very soon, and this process can be slowed by adding drops of lemon juice into it.
4. Leaves and stems (such as those of lettuce) can be put into the extractor to extract juice.

Section 6. Maintenance

1. Before cleaning this product, be sure to shut down the switch to disconnect the power supply.
2. Clean this product after using it.
3. The Housing cannot be washed under water, and must be cleaned with twisted wet cloth instead.
4. Before storing it, make sure this product is clean and dry.
5. Disassemble this product to wash the components by the following steps:

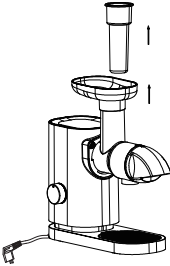
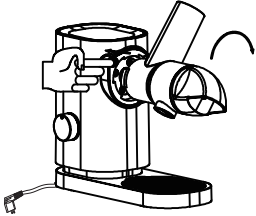
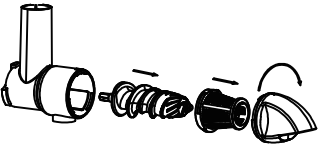
	1	First remove the plunger and tray.
	2	Press down and hold the locking button, and rotate the drum clockwise to remove it.
	3	First remove the plunger and tray. Press down and hold the locking button, and rotate the drum clockwise to remove it. After removing extractor, detach the end cap, juice screen and auger in turn, all removable components can be washed with water.

Section 7. Only Hand Wash & Easy Cleaning

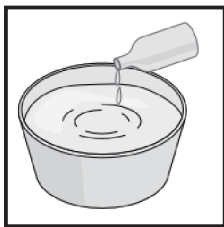

1.HANDWASH OPTION:

You can thoroughly wash parts by immersing in warm water diluted with one or two drops of baking soda or dishwashing soap for about 30 minutes.

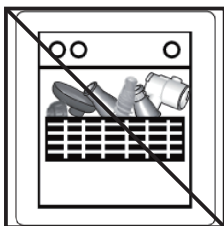

2.NOT DISHWASHER SAFE:

After using the juicer, remember not to put the relevant attachments of the juicer into the dishwasher for cleaning, because washing in the dishwasher will cause damage to the relevant attachments and cause the juicer to stop working.

WARNING

Do not immerse the motor base in water or any other liquid. Do not use water jet to clean the motor base.

Section 8. Safety Index

PRODUCT NAME:	slow juicer
MODEL:	ZM1507A
RATED VOLTAGE:	120V
RATED POWER:	150W
RATED FREQUENCY:	60Hz
CONTINUOUS OPERATING TIME:	≤ 10 minutes
INTERVAL TIME:	≥ 10 minutes
SPEED:	90~30 rpm/min
LOAD	carrot,apple

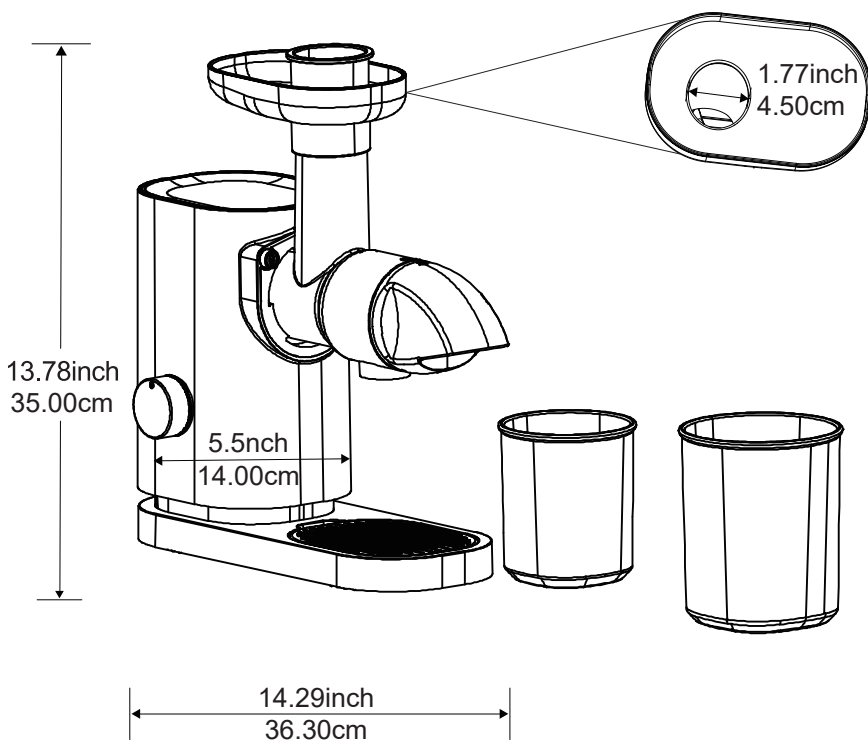

Section 9.Warranty

Thank you for choosing A aobosi product. We sincerely hope that you are satisfied with it.

The manufacturer's warranty covers the product for a period of 12 months from the date of purchase against manufacturing faults. All warranties are automatically kept track of in our system, so there is no need to register your product.

Agent/Distributor is welcome to contact us. Email:info@iaobosi.com.

Any help or questions during use, please contact us via website www.iaobosi.com, send email to info@iaobosi.com, we will service you within 24 hours. We suggest to provide a warranty card, a photo or a video if there's broken spare part or not working machine so that we can be much more clear about your problems and offer you the best solution.



aobosi Warranty Card

Item name: _____

Model: _____

Serial No.: _____

Store name: _____

Purchase date: _____

Buyer's name: _____

Email: _____

Address: _____

Tel.: _____

Please fill in the table and email it within 10 days from the date of purchase.

Section 10. Troubleshooting

Please troubleshoot using the details below before contacting A aobosi Customer Service for repair or service. When contacting A aobosi for after-sales service, please have the manufacturer's serial number or bar code available.

The Appliance Does Not Work

- Make sure the power cord is plugged in correctly.
- Make sure the drum is assembled correctly. If the drum is not locked into place,the appliance will not operate.
- Make sure the appliance is assembled according to the instructions in this manual.
- Refer to the instructions.If the appliance still does not work, please contact A aobosi Customer Service for additional support.

The Drum Does Not Open

- If there is a lot of pulp inside the drum, press [On] to release the excess pulp.
- Check the appliance for any foreign substance or solid objects including seeds.
- Press Rev] button to push up stuck ingredients.
- Do not attempt to open by force. If the drum still does not open, please contact Aaobosi Customer Service for additional support.

The Appliance Stops During Normal Operation

- Check for large pieces of food stuck in the appliance.

Noise is generated during operation

- The machine operates in an unbalanced state due to failure to mount auger or juice filter in place.Mount auger or juice filter in place.
- The starting motor in the frame has been damaged.Contact after Sales Support.

- Refer to the section "If the Auger Stops Working" and follow the guideline for the Rev] button.
- If the appliance still does not work, please contact Aaobosi Customer Service for additional support.

Fine Lines or Scratch Marks around the Auger

- This is normal. Do not be concerned. These are molding marks resulting from the normal manufacturing process.

Juice Leaks Over the Base

- Check for an excessive amount of ingredients in the hopper and/or chute.
- If you try to juice a large amount of food compared to the pulp chute, the packing will be slightly pushed away. Juice may leak out of the gap.
- Do not force too much food into the juicer. Push food gradually for extraction.
- Check to make sure the juice flap is closed.

Juicer Shakes when In-Use

- This is normal as the auger rotates. It is not a malfunction. Hard ingredients such as carrots, potato, radish, beets, etc. may cause shaking more so than soft ingredients
- Depending on the firmness of the ingredient, there may be a more pronounced shaking of the motor.

During the early uses, the motor generates unpleasant smel

- It is a normal phenomenon.
- If this phenomena occurs frequently, please contact A aobosi Customer Service for additional support.