



FLORENCE CIRCULAR DINING TABLE

MCM HOUSE

Assembly instructions

- We suggest you spend a short time reading through this leaflet and then follow the simple step by step instructions.
- Do not discard any of the packaging until you have checked that you have all the parts and the pack of fittings.

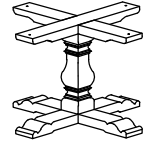

PARTS

A  Top 1x	B  Base 1x	C  Ø5x50mm 4x	D  Pre Drill Bit 1x
---	--	--	---

REQUIRED

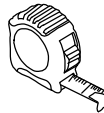

2 people
required for
assembly

1  Impact Driver	2  Brushless Hammer Drill	3  Phillips Head Bit	4  Tape Measure
--	---	--	---

1

- To protect your floor and your new Dining Table, lay a drop sheet or something that is a clean soft surface.
- Lay your new table top face down on the Drop sheet.
- Use your tape measure(4) to ensure table top is centered, be sure there is equal distance to the edge of the table top.

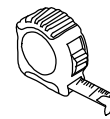
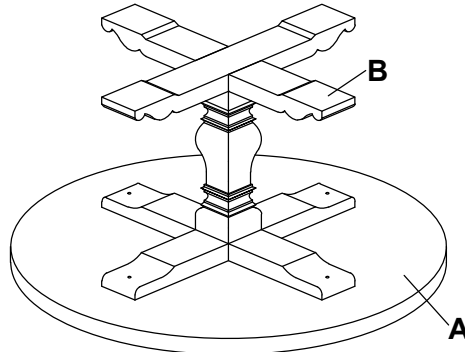

TAPE MEASURE(4)
(NOT PROVIDED)

2

- On your Pre Drill Bit (D), use a tape measure(4) to determine 50mm from the end of the drill bit.

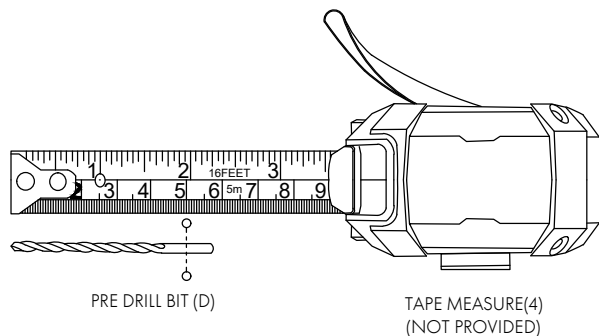

3

- Once the Table base is centered, use the Brushless Hammer Drill(2) with the Pre Drill Bit (D) to pre-drill holes no deeper than 20mm.
- Ensure to predrill slowly at an even pressure, directly from above - ensure you are not on an angle.

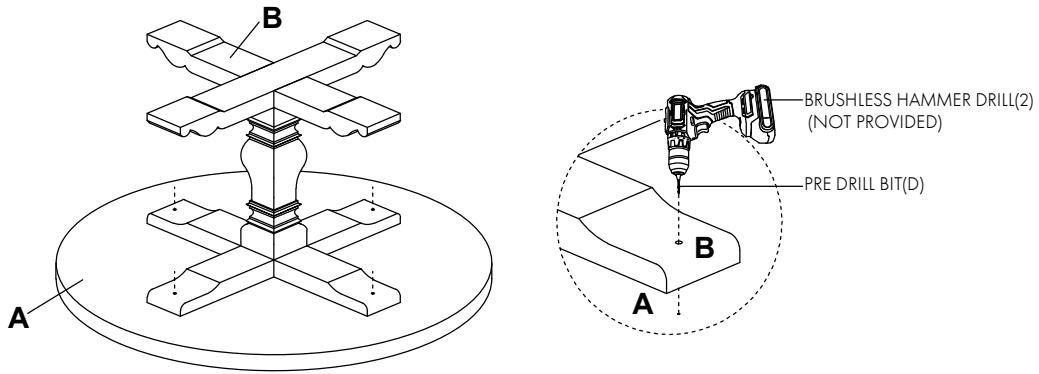

4

- Switch to using your Impact Driver(1)
- Using screw (C) in your Impact Driver, apply even pressure until 1/3 of the screw is submerged into the tabletop. Switch your drill to reverse and reverse the screw out, change back to drill and screw down until the screw is 2/3 submerged into the table top, then reverse out again, then change back to drill and drill down until the screw is fully submerged into the table top and flush on the surface.

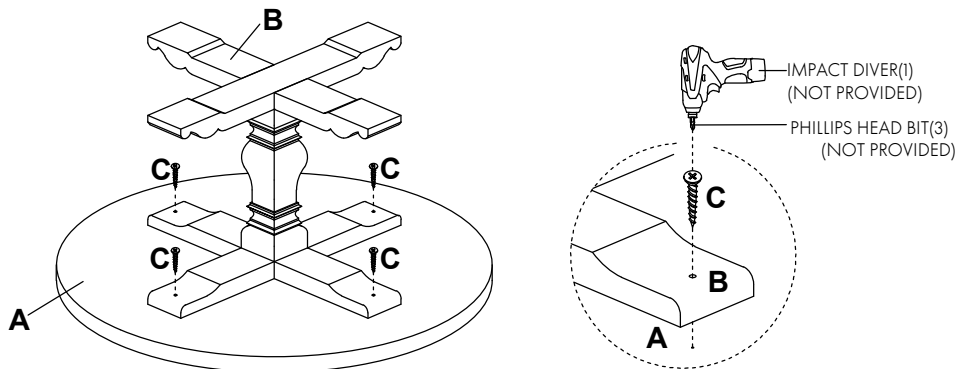

5

- Carefully turn the table to be on the right side up, and place it in your desired location.

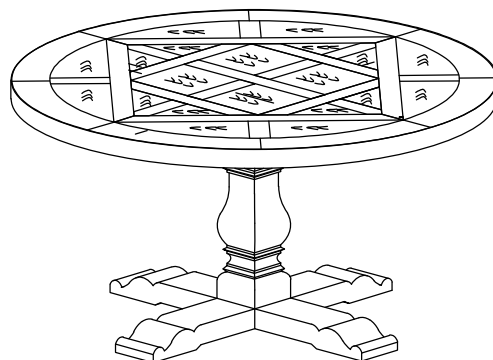

WARNING:

- These table parts can be cumbersome and heavy; the assistance of two or more people is recommended in order to prevent personal injury and ensure the table parts are not damaged during the assembly process.
- Keep fittings out of childrens' reach