

NOTE: *Keep service delivery line lengths equal to a maximum of 2m.
 **Master assembly should be mounted in the center of the axle group.

PLEASE NOTE: ANY CHANGES MADE FROM THIS DRAWING LAYOUT OR ITS COMPONENTS WILL VOID THE 'ADR' COMPLIANCE. DO NOT USE ANY LINE LENGTH LONGER THAN THE MAXIMUM SPECIFIED. REFER TO DRAWING 'M004 INSTALL' FOR INSTRUCTIONS.

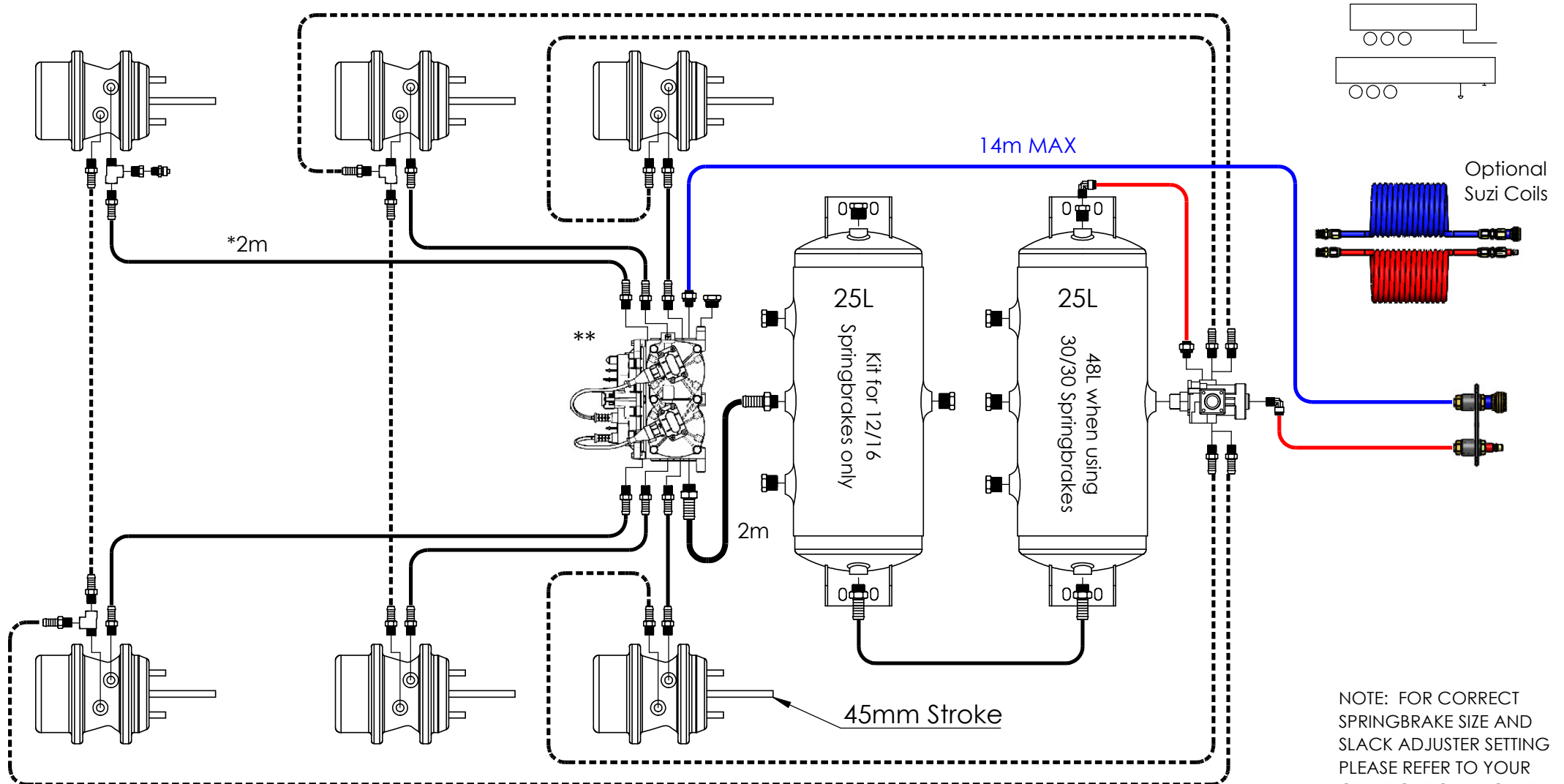

NOTE: FOR CORRECT SPRINGBRAKE SIZE AND SLACK ADJUSTER SETTING PLEASE REFER TO YOUR CERTIFICATION ENGINEER.

- Service Line (Ø3/8" Blue Nylon)
- Supply Line (Ø3/8" Red Nylon)
- Service Delivery (Ø1/2" Black Rubber Hose)
- - - Emergency Delivery (Ø1/2" Black Rubber Hose)
- Supply Line (Ø3/4" Black Rubber Hose)

**ADR 38/05
COMPLIANT**

Drawn By: AD	Description: Tri ABS 24v
Date: 26/04/19	Part No: BKABS003
Revision: 2	SARN: 47924

