

B100SE - Super Swing

Instruction Manual

Document number: B100SE-C

Release: V1.0

Date: July 18,2012





This control must be adjusted/serviced by a qualified person. The service technician must be familiar with the latest ANSI A159.10/19 standards.

NEVER sacrifice the safe operation of the automatic door for an incomplete solution. Call the factory for technical support.

Permanent wiring shall be employed if required by local codes. Refer to connector J3 section for wiring references.

B100S Module Description/Connector Pinouts

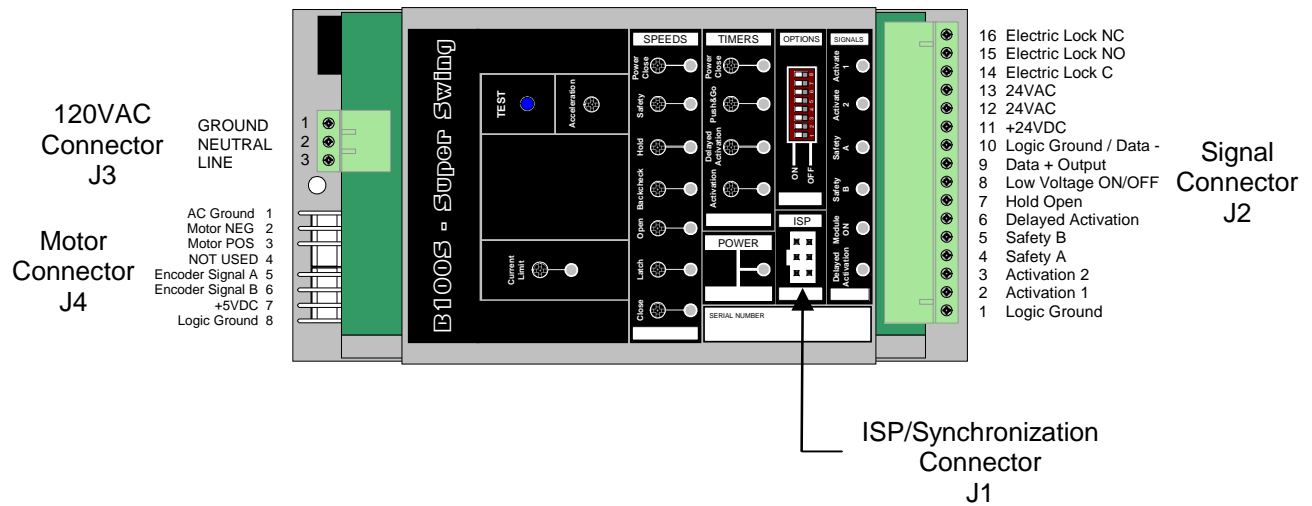

ISP/Synchronization Connector – J1

ISP – (In System Programmer) **FACTORY USE ONLY**

Synchronization – This connector is used to synchronize two modules together (For Dual door operator). Synchronization cable part number is B100S-SYNC. When the synchronization cable is used, the activation switch(es)/sensor(s) can be wired to only one module. All signals, except for the “Delayed Activation”, are shared between the two modules via the synchronization cable. When the “Delayed Activation Timer” expires, an activation signal is sent to the mate control.

Note: Using the synchronization cable will not synchronize the door speeds. The speeds are kept separately.

Signal and Sensor Power Connector – J2

	PIN	Signal	Definition	
	J2.1	Logic ground	Ground reference for signals and power	
	J2.2	Activation 1	This signal to ground will activate the operator, If the module is in the ON mode (Low voltage ON/OFF must be to ground) and no current fault is present.	
	J2.3	Activation 2	This signal to ground will activate the operator, If the module is in the ON mode (Low voltage ON/OFF must be to ground) and the door is in motion and no current fault is present.	
	J2.4	Safety A	When the door is fully closed, this signal to ground will prevent an activation. When the door is fully opened, this signal to ground will prevent the door from entering the closing cycle.	
	J2.5	Safety B	When the door is fully closed, this signal to ground will prevent an activation. During the opening cycle, the door will go to safety speed when this signal is to ground. During the closing cycle, the door will go to a very slow speed when this signal is to ground. When the door is fully opened, this signal to ground will prevent the door from entering the closing cycle, unless option #2 is set to "ON" (Disable Safety B at backcheck).	
	J2.6	Delayed Activation	Delayed Activation This signal to ground will start the delayed activation timer. When the timer expires, an activation is generated. This signal is used to do door sequencing.	
	J2.7	Hold open	This signal to ground will hold the door opened, if the module is in the ON mode (Low voltage ON/OFF must be to ground) and no current fault is present.	
	J2.8	Low voltage ON/OFF	This signal to ground enables the module. The module is disabled if this signal is not to ground	
	J2.9	Data +	This is a signal output for sensor which requires door status information. When door is closed, Data output is 0V When door is in the opening cycle, Data output is 12V When door is closing (In motion), Data output is 8V	
	J2.10	Logic ground / Data -	Ground reference for signals and power	
	J2.11	(+24VDC)	DC power for sensors	(300mA max.)
	J2.12	(24VAC)	AC power for sensor	
	J2.13	(24VAC)		
	J2.14	Electric lock switch (Common)	This connection is the common to drive an electric lock (Active when electric lock option is set to ON)	
	J2.15	Electric lock switch (Normally open)	This connection is the normally open (NO) to drive an electric lock (Active when electric lock option is set to ON)	
J2.16	Electric lock switch (Normally close)	This connection is the normally close (NC) to drive an electric lock (Active when electric lock option is set to ON)		

Power Source (120VAC input connector) - J3

	PIN	Signal Definition
	J3.1	AC Ground
	J3.2	AC Neutral
	J3.3	AC Line

Power required is 120 VAC 60Hz 260W Max.

Motor Connector - J4

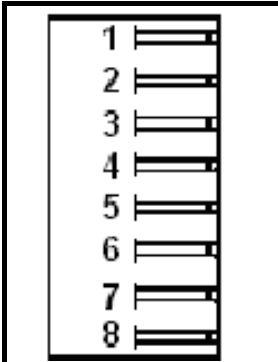
	PIN	Signal	Definition
	J4.1	Motor AC Ground	This connection is used to ground the motor body when applicable
	J4.2	Motor NEG	This connection goes to the negative of the motor
	J4.3	Motor POS	This connection goes to the positive of the motor
	J4.4	Polarizing key (NC)	This is used to polarize the connector
	J4.5	Encoder signal A	Encoder signal A
	J4.6	Encoder signal B	Encoder signal B
	J4.7	+5VDC	Power for encoder
	J4.8	Logic ground	Ground reference for signals

Option Switches

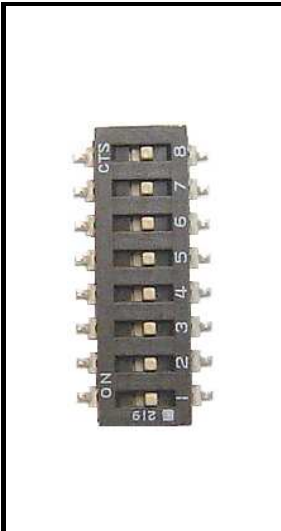
	Switch	Definition
	1	Push & Go - For operator without a clutch (Use for handicap operator ONLY) If this switch is set to ON, the operator is activated when door is manually pushed.
	2	Disable Safety B at backcheck If this switch is set to ON, Safety B is disable at backcheck
	3	Electric Lock If this switch is set to ON, a small delay is added prior to the door opening to allow to unlock the electric lock.
	4	Power Close If this switch is set to ON, a reverse power is applied when the door stalls at the latch position.
	5	Reverse on obstruction If this switch is set to ON, during a closing cycle, if the door stalls before the latch position, a re-activation is generated.
	6	Push & Go - For operator with a clutch (Use for handicap operator ONLY) If this switch is set to ON, the operator is activated when door is manually pushed outside the latch zone.
	7	Door Seal (Power Close option must be set to ON) If this switch is set to ON, the operator will create a small resistance to prevent the door to open.
	8	NOT USED

Note: Safety A has a permanent lockout during the opening and closing of the door. Safety A is active when the door is fully closed or fully opened.

Before applying power to the operator, make all necessary connections (Refer to the wiring diagrams at the end on the document).

1 Installation Check

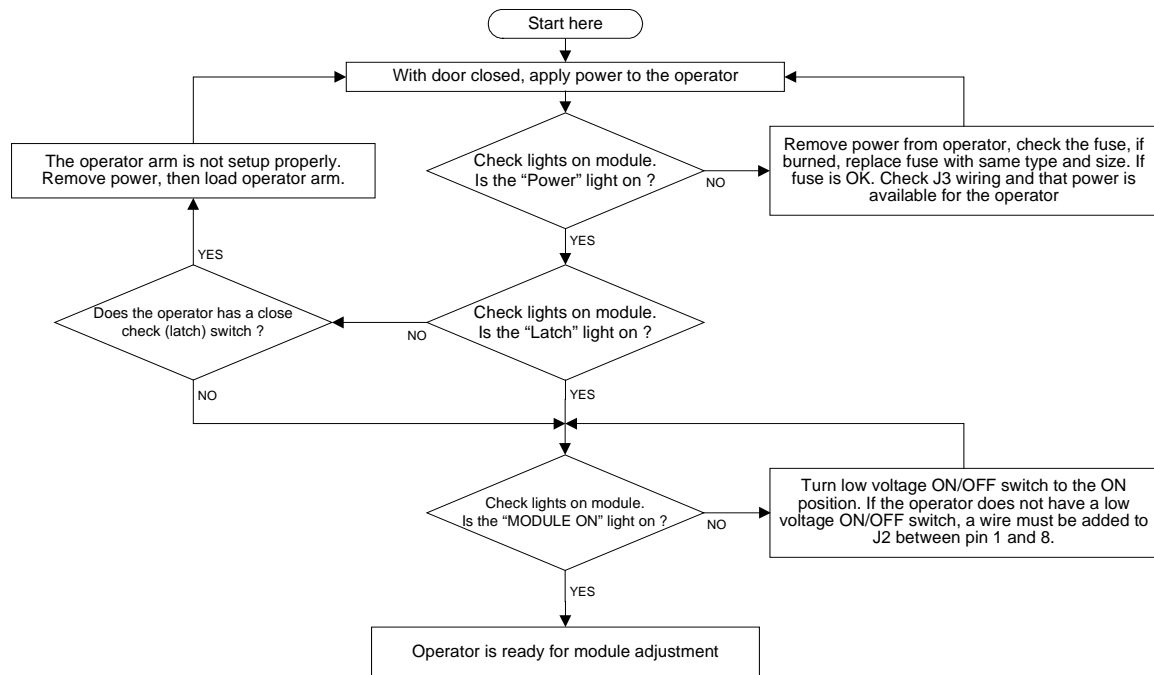

2 Module Adjustment

All trimmers are at minimum values when turned fully counter clock wise and are at maximum values when turned fully clockwise. A speed or timer trimmer is active when the corresponding light (LED) is lit.

Current Limit Trimmer/Light – Obstruction Fault on opening

During an opening cycle, if the motor exceeds the allowed current limit defined by the current limit trimmer, a red light (LED) will lit, the opening cycle is cancelled and the operator is disabled for ten seconds.

Before beginning the adjustments, set the following:

- 1- Activation timer trimmer to $\frac{1}{4}$ turn from the minimum
- 2- Current Limit trimmer to the maximum (Fully clock wise)
- 3- Close and Latch Speed trimmers to minimum (Fully counter clock wise)
- 4- Set all option switches to the "OFF" position. If an electric lock is used, set option #3 to the "ON" position

2.1 Basic Adjustments

Activate the operator by pushing the test button (using a small screwdriver).

1. Adjust "OPEN" speed trimmer so that the door arrives at back-check in no greater than 3 seconds for Handicap applications.
2. Adjust "BACK-CHECK" speed trimmer so that door creeps to final open in no less than 2 seconds for Handicap applications.
3. Adjust "HOLD" force trimmer so that the power is just enough to hold door at full open without drifting closed.
4. Adjust "ACTIVATION" so that the door remains in the full open position for no less than 5 seconds for Handicap applications.
5. Adjust "CURRENT LIMIT" so that the door stops when it meets an obstruction during the opening cycle. Cycle test several times.
6. Adjust "ACCELERATION" so that upon activation during close cycle the door reverses smoothly. **(NOT SUPPORTED AT THIS TIME)**
7. Adjust "CLOSE" speed so that door closes no faster than 4 seconds to latch-check.
8. Adjust "LATCH" so that door closes the final 10 degrees without slamming.

2.2 Other Adjustments and Options

2.2.1 Safety Speed Trimmer

If a safety sensor is used, follow these steps to adjust the safety speed.

- 1- Push the test button to generate an open cycle.
- 2- During the open speed (Before backcheck) generate a safety signal
- 3- With the safety signal present, adjust the safety speed trimmer to achieve a creep or a stall motion of the door.

NOTE: If the safety sensor is a header mount type (Sensor will detect the door when the door swings in front of it), "Safety A" input must be used for that sensor and the lockout option must be set to the "ON" position (Option switch #2).

2.2.2 Push & Go Timer Trimmer

If Push & Go is needed set the option to the "ON" position.
The B100S has two types of Push & Go,

- 1- Option #1 Push & Go for operators without a clutch
- 2- Option #6 Push & Go for operators with a clutch (Operator must have a close check (latch) switch to use this option)

After the proper Push & Go option has been selected, manually push the door open. The controller will detect the door movement and will generate an open cycle. Adjust the Push & Go timer trimmer for the desired opening time for a Push & Go activity.

2.2.3 **Power Close Timer and Speed Trimmers**

If power close is needed, set the option #4 to the "ON" position. Follow these steps to adjust the length and strength of power close.

- 1- With option #4 set to the "ON" position, push the test button to generate an opening cycle.
- 2- When the door enters the closing cycle and reaches the latch area, stall the door open. When power close activates, adjust the power close speed trimmer for the desired strength.
- 3- Generate another opening cycle, when power close activates, set the length of the power close buy adjusting the power close timer trimmer. (1 - 6 seconds)

Note: The operator must have a close check (Latch) switch to use this feature.

2.2.4 **Door Seal**

If a positive pressure causes the door to slightly open, the door seal option #7 can be used. For option #7 Door Seal to work, option #4 Power Close must be set to "ON". If power close is not needed, then set the power close speed and timer trimmers to the minimum (Fully counter clock wise).

2.2.5 **Reverse on Obstruction**

Set option #5 to the "ON" position to activate the reverse on obstruction option. When the door stalls between the backcheck and latch position, the controller will generate a re-opening cycle.

Note: The operator must have a close check (Latch) switch to use this feature.

2.2.6 **Delayed Activation Timer**

The activation signal of another operator can be connected to the delayed activation input to create door sequence operation. When used, adjust the delayed activation timer trimmer to create the proper delay.

For further information contact technical support.

