

VOLANT COOL AIR INTAKES  
 PART NO.: 19068  
 INSTALLATION INSTRUCTIONS  
 WWW.VOLANT.COM  
 TECH SUPPORT: (909) 481-3888

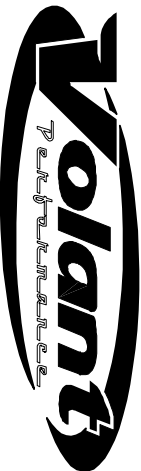

		16059 PARTS LIST			
1	VOLANT FILTER BOX	1	3 1/2" HUMPH HOSE	1	3/16" GASKET
1	VOLANT LID	1	4 1/2" X 2 1/4" SLEEVE	1	1/2" RUBBER GROMMET
1	VOLANT AIR DUCT	4	6 MM-16 BOLTS	1	1/2" SENSOR PLUG
1	MASS FLOW ADAPTER	4	6 MM NUTS		
1	RAM FILTER W/CLAMP	4	1/4" TRUSS HEAD SCREWS		
2	#056 CLAMPS	4	1/4" RUBBER WASHERS		
2	#072 CLAMPS	4	1/4" LOCK WASHERS		

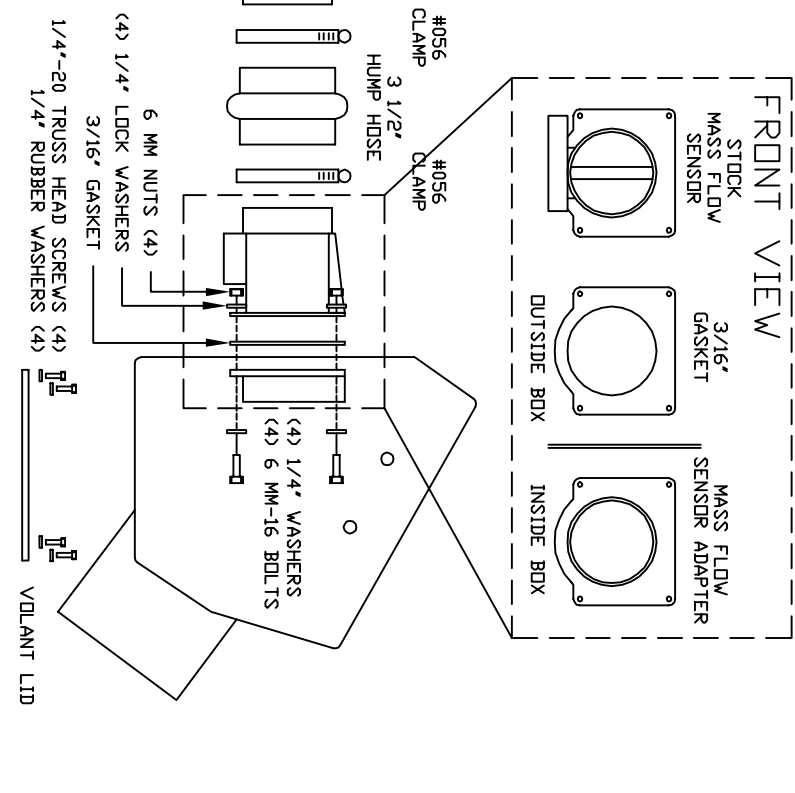

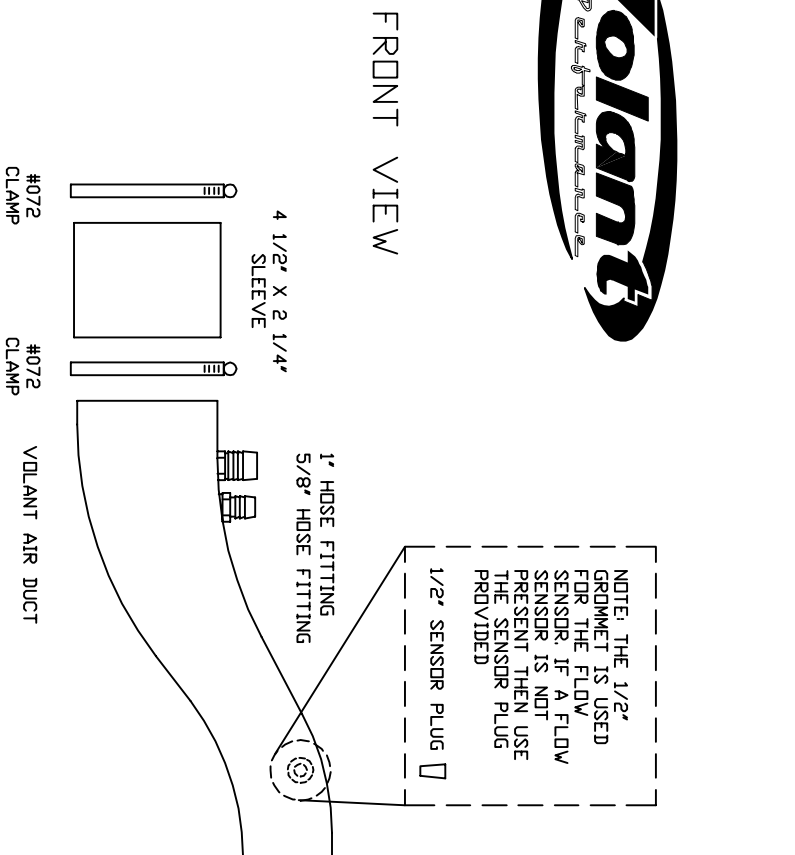

Volant Performance  
 Rancho Cucamonga, CA 91730  
 (909) 481-3888 Tech Support  
 (909) 476-1491 Fax  
 www.volant.com

**READ INSTRUCTIONS THOROUGHLY BEFORE DISASSEMBLING. DO NOT SKIP ANY STEPS. ANY QUESTIONS ON A VOLANT KIT MAY BE REFERRED TO OUR TECH SUPPORT LINE AT (909) 481-3888 OR VISIT OUR WEBSITE AT WWW.VOLANT.COM**

**INSTALLATION INSTRUCTIONS PART NO. 19068**

**Installation Instructions:**

1. Turn the vehicle to the off position and disconnect the negative battery cable.
2. The 6.8L had mid year changes so some models are equipped with an external air temperature sensor. Disconnect the air temperature connection from the sensor.
3. Pull the idle air control and PCV hose off the stock duct near the throttle body.
4. Loosen the hose clamps on the air intake duct at the throttle body and the filter box assembly. Pull the duct off both locations and remove.
5. Follow the electric harness from the stock filter box and disconnect the plug from the harness on the chassis.
6. Remove the entire filter assembly from the vehicle by pull it off the rubber grommets.
7. Separate your filter box in two by unclipping the filter box latch. To remove the encased mass flow sensor, insert a flathead screwdriver in one of the small slots located on the lid of the half filter box with the wire harness. Carefully pry open the lid and disconnect the mass flow sensor inside. Remove the lid and the mass flow sensor completely. Unscrew the two bolts that fasten the sensor to the lid with a 10mm socket and ratchet wrench
8. Relocate the mass flow sensor along with the sensor gasket to the outside Volant filter box and the Volant sensor adapter and gasket inside. Secure them both with the four (4) 1/2"-20 bolts, 1/4" washers and nuts provided.
9. Loosen and remove the three bolts that hold the filter box mounting bracket down. Remove the mounting bracket. Note: If you have a 2004 or later you need to remove the four bolts that hold the mounting bracket and air box evap canister bracket. Remove the filter box mounting bracket only from the vehicle.
10. Install the Volant filter box using the same stock hardware and two mounting location where the evaporative canister and filter box tray mounted.
11. Slip the 4.5 Volant sleeve on the throttle body with the two 72 clamps.
12. Attach the 3.5 inch hump hose to the mass flow sensor on the Volant filter box and tighten with the 56 clamp. Place the other 56 clamp on the other end.
13. Install the oval end of the Volant air intake duct to the throttle body and the other end to the hump hose. Do not tighten until entire unit is in place, this will allow adjustment.
14. Connect the two hoses back onto the Volant air duct.
15. If equipped with air temp. sensor. Remove the air temperature sensor from the stock air intake.
16. Reinstall the sensor in the 1/2 rubber grommet on the Volant duct and reconnect it to the same wire harness on the vehicle. Note: if you do not have a sensor insert the plug provided in the 1/2 grommet.
17. Reconnect the mass flow sensor wire harness back to the engine harness and the other to the stock mass flow sensor.
18. Connect the Volant filter to the adapter inside the Volant filter box.
19. Cover the Volant filter box with the lid provided and the 4 stainless steel screws.
20. Make sure the clamps on the Volant air duct are tightened and properly connected.

**WARNING: OVER TIGHTENING HARDWARE MAY ALTAR THE INTEGRITY OF THE VOLANT AIR INTAKE SYSTEM.**

**BEFORE ROAD TESTING**

1. Start engine, leaving the transmission in park and securing the parking brake.
2. Make sure to look and listen for any unusual noises or air leaks. Repair problems if needed.
3. Once completed it will be necessary to check periodically for realignment and tightening of all connections.
4. Once all tests are completed, enjoy the performance of your new Volant Air Intake System.

**CARE AND CLEANING**

Check the cotton reusable filter periodically and remove any excessive dirt build-up by tapping the filter on the ground and brushing off the loosened dirt. Clean the filter by using Volant's Filter Recharger Kit. Volant's Filter Recharger Kit is designed to restore original air flow. Re-oil every 10,000 miles without cleaning to improve filtering in sand and dirt. Clean only when dirt is very excessive or 50,000 miles.

**RECOMMENDED SERVICE PARTS**

RECOMMENDED SERVICE PARTS	PART NO.
REPLACEMENT FILTER	5111
PREFILTER	51906
CLEANING KIT	5100

**APPLICATION GUIDE**

MY	MAKE	MODEL	ENG.
99-03	FORD	EXCURSION	6.8L
99-04	FORD	F-250	6.8L
99-03	FORD	F-350	6.8L

**INSTALL**

