

SC250, Scrubtec 334, MA 30



Service Manual

Advance SC250, 9087381020

Nilfisk SC250, 9087380020

Nilfisk Scrubtec 334, 9087382020

Clarke MA 30, 9087383020



English
08-2016 - Revised 03-2017
Form No. 910002116

Contents

03 - General Information.	4
Machine General Description	4
Service Manual Purpose and Field of Application	4
Other Reference Manuals	4
Conventions	5
Serial Number Label	5
Safety	6
Visible Symbols on the Machine	6
Symbols	6
General Instructions	7
Machine Transportation	9
Machine Nomenclature (know your machine)	10
Service and Diagnostic Equipment	13
Technical Data	14
Dimensions	15
Scheduled Maintenance Table	16
04 - Control System	17
Functional Description	17
Wiring Diagram	18
Component Locations	19
Removal and Installation	20
Main Machine Controller (EB1)	20
Main Control Board (EB2) and Hand Presence Sensors (S1, S2)	26
Specifications	30
Main Machine Controller (EB1) Connectors	30
Main Control Board (EB2) Connectors	35
10 - Chassis System	38
Chassis (main parts)	38
14 - Wheel System, Non Traction	39
Functional Description	39
Component Locations	39
Specifications	40
24 - Electrical System.	41
Functional Description	41
LED Operation on Main Control Board	41
Wiring Diagram	42
Component Locations	43
Maintenance and Adjustments	44
Battery Installation	44
Battery Charging	44
Battery Charge Level	45
Charging the Battery when Removed from the Machine	46
Display on Battery	47
Troubleshooting	48
Battery LED behavior	48
Specifications	49
Wiring Diagram	50

30 - Solution System	51
Functional Description51
Wiring Diagram52
Component Locations53
Maintenance and Adjustments54
Cleaning the Solution Tank and Filter54
Solution Dispenser Cleaning55
Troubleshooting56
Water Pump Voltage and Cleaning Check56
Removal and Installation59
Solution Tank Valve59
Water Pump60
Water Sensor61
Specifications62
34 - Scrub System	63
Functional Description63
Wiring Diagram64
Component Locations65
Maintenance and Adjustments66
Brush and Brush Compartment Cleaning66
Troubleshooting67
Brush Motor Amperage Check68
Removal and Installation70
Driving Belt70
Brush Motor72
Specifications75
38 - Squeegee System	76
Functional Description76
Maintenance and Adjustments78
Squeegee Bar Cleaning78
Troubleshooting79
Removal and Installation80
Vacuum Duct80
Specifications84
40 - Recovery System	85
Functional Description85
Wiring Diagram85
Component Locations86
Maintenance and Adjustments87
Recovery Tank and Cover Cleaning87
Air Filter, Gaskets and Recovery Water Duct Cleaning88
Troubleshooting89
Vacuum System Motor Amperage Test90
Removal and Installation92
Vacuum System Motor92
Specifications98
90 - Options	99

03 - General Information

Machine General Description

The SC250 Scrubtec 334 is an operator pushed industrial machine designed to wash and dry floors in one pass. The machine is powered by one on-board battery. The machine is equipped with a cylindrical brush, a controlled solution flow dosing system and a front/rear squeegee assembly with blades, which vacuums and dries the floor.

Service Manual Purpose and Field of Application

This Service Manual is a technical resource intended to help service technicians when carrying out maintenance and repairs on the scrubber-dryer, to guarantee the best cleaning performance and a long working life for the machine.

Please read this manual carefully before performing any maintenance and repair procedure on the machine.

Other Reference Manuals

Model	Product Code	User Manual	Spare Parts List
Nilfisk SC250	9087380020	9100001614	9100001615
Nilfisk Scrubtec 334	9087382020		
Advance SC250	9087381020	9100001616	9100001617
Clarke MA30 13 B	9087383020	9100001622	

These manuals are available at:

- Local Advance, Nilfisk or Clarke retailer
- Advance website: www.advance-us.com
- Nilfisk website: www.nilfisk.com
- Clarke website: www.clarkeus.com
- EZ-Data application

Conventions

Forward, backward, front, rear, left or right are intended with reference to the operator's position, that is to say in driving position.

Serial Number Label

Reference to Figure 1

The machine serial number and model name are marked on the plate (see the example to the side). Product code and year of production are marked on the same plate (Date code: A16, means January 2016).

This information is useful when requiring machine spare parts.

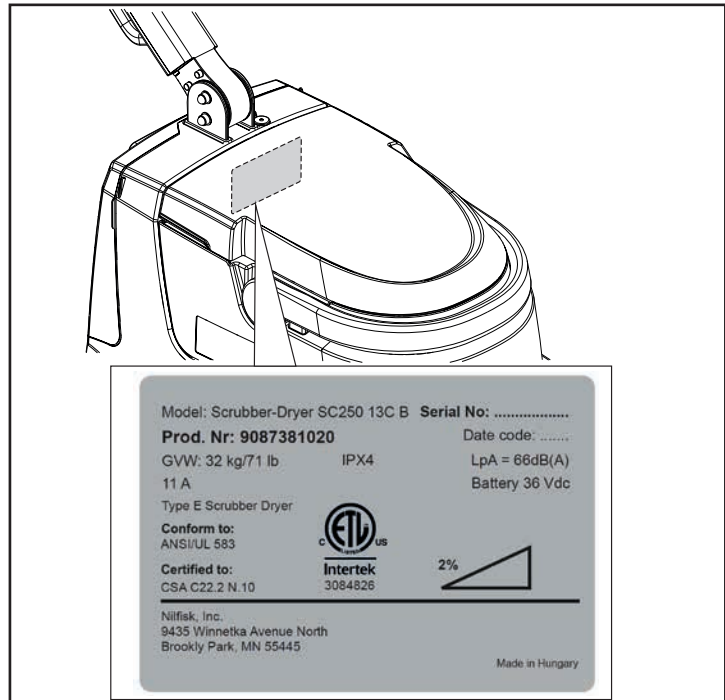
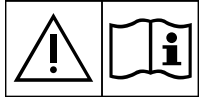

Figure 1

Safety

The following symbols indicate potentially dangerous situations. Always read this information carefully and take all necessary precautions to safeguard people and property.

Visible Symbols on the Machine



Warning! Carefully read all the instructions before performing any operation on the machine.

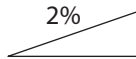

Warning! Do not use the machine on slopes with a gradient exceeding the specifications.

Symbols



Danger! It indicates a dangerous situation with risk of death for the operator.



Warning! It indicates a electrostatic sensitive components.



Warning! It indicates a potential risk of injury for people or damage to objects.



Caution! It indicates a caution related to important or useful functions.



Note: It indicates a remark related to important or useful functions.

General Instructions

Specific warnings and cautions to inform about potential damages to people and machine are shown below.



Danger! *Make sure to follow the safety precautions to avoid situations that may lead to serious injuries.*

- Before performing any maintenance, repair, cleaning or replacement procedure disconnect the battery.
- This machine must be used by properly trained operators only.
- Do not wear jewels when working near electrical components.
- Do not operate the machine near toxic, dangerous, flammable and/or explosive powders, liquids or vapors. This machine is not suitable for collecting dangerous powders.



Danger! *(For battery and battery charger).*

- Read all safety warnings and all instructions. Failure to follow the warnings and instructions may result in electrical shock, fire and/or serious injury.



Warning! *(For battery and battery charger).*

- This machine is equipped with a lithium ion battery.
- Do not use any other type of batteries; only use the one supplied with the machine or its original spare part.
- Before each used, check if it's damaged.
- Do not soak in liquids.
- Under abusive conditions, liquid may be ejected from the battery; avoid contact. If contact accidentally occurs, flush with water. If liquid contacts eyes, additionally seek medical help. Liquid ejected from the battery may cause irritation or burns.
- Do not use a battery pack or appliance that is damaged or modified. Damaged or modified batteries may exhibit unpredictable behavior resulting in fire, explosion or risk of injury.
- Do not expose a battery pack or appliance to fire or excessive temperature. Exposure to fire or temperature above 130 °C (256 °F) may cause explosion.
- Do not store, use or recharge in environments with a temperature higher than 45 °C.
- Do not recharge with temperatures lower than 0 °C.
- Due to the risk of short-circuit, do not store the battery with metal objects.
- If the battery is damaged, take it to a Service Centre.
- Before decommissioning the machine, remove the battery.
- Store the battery charger in a dry place.
- If the battery charger or the cable are wet, do not use it.
- Before using the battery charger, make sure that the frequency and voltage values, marked on the plate, correspond to the mains voltage values.
- Do not use the battery charger in environments where there are flammable powders and/or explosive materials.
- Do not handle the battery charger by its main cable.
- Do not pull or carry the machine by the battery charger cable and never use the battery charger cable as a handle. Do not close a door on the battery charger cable, or pull the battery charger cable around sharp edges or corners. Do not run the machine on the battery charger cable.
- Keep the battery charger cable away from heated surfaces.
- Do not charge the battery if the battery charger cable or the plug are damaged.
- Do not cover the battery charger.
- Always use the battery charger supplied with the machine or the original spare part. Any other battery charger must have the same specifications indicated in the chapter Technical Characteristics and must supply a Safety Extra Low Voltage (SELV).



Caution! *Make sure to follow the safety precautions to avoid situations that may lead to serious injuries, damages to materials or equipments.*

- Carefully read all the instructions before performing any maintenance/repair procedure.
- To reduce the risk of fire, electric shock, or injury, do not leave the machine unattended when it is plugged in. Before performing any maintenance procedure, disconnect the battery charger cable from the electrical mains.
- Do not smoke while charging the battery.
- Always protect the machine against the sun, rain and bad weather, both under operation and inactivity condition. This machine must be used indoors in dry conditions, it must not be used or kept outdoors in wet conditions.
- Before using the machine, close all doors and/or covers as shown in the Instructions for Use Manual.
- This machine is not intended for use by persons (including children) with reduced physical, sensory or mental capabilities, or lack of experience and knowledge, unless they have been given supervision or instruction concerning use of the machine by a person responsible for their safety.
- Children should be supervised to ensure that they do not play with the machine.
- Close attention is necessary when used near children. Use only as shown in this Manual. Use only Nilfisk's recommended accessories.
- Check the machine carefully before each use, always check that all the components have been properly assembled before use. If the machine is not perfectly assembled it can cause damages to people and properties.
- Take all necessary precautions to prevent hair, jewels and loose clothes from being caught by the machine moving parts.
- Do not use the machine on slopes.
- Do not use the machine on slopes with a gradient exceeding the specifications.
- Do not use the machine in particularly dusty areas.
- Use the machine only where a proper lighting is provided.
- While using this machine, take care not to cause damage to people or objects.
- Do not bump into shelves or scaffoldings, especially where there is a risk of falling objects.
- The machine working temperature must be between 0 °C and +40 °C.
- The machine storage temperature must be between 0 °C and +40 °C.
- The humidity must be between 30 % and 95 %.
- When using floor cleaning detergents, follow the instructions on the labels of the detergent bottles.
- To handle floor cleaning detergents, wear suitable gloves and protections.
- Do not use the machine as a means of transport.
- Do not allow the brush/pad to operate while the machine is stationary to avoid damaging the floor.
- In case of fire, use a powder fire extinguisher, not a water one.
- Do not tamper with the machine safety guards and follow the ordinary maintenance instructions scrupulously.
- Do not allow any object to enter into the openings. Do not use the machine if the openings are clogged. Always keep the openings free from dust, hairs and any other foreign material which could reduce the air flow.
- Do not remove or modify the plates affixed to the machine.
- This machine cannot be used on roads or public streets.
- Pay attention during machine transportation when temperature is below freezing point. The water in the recovery tank or in the hoses could freeze and seriously damage the machine.

- Use brushes and pads supplied with the machine or those specified in the User Manual. Using other brushes or pads could reduce safety.
- In case of machine malfunctions, ensure that these are not due to lack of maintenance. If necessary, request assistance from the authorised personnel or from an authorised Service Center.
- If parts must be replaced, require ORIGINAL spare parts from an Authorised Dealer or Retailer.
- To ensure machine proper and safe operation, the scheduled maintenance shown in the relevant chapter of this Manual, must be performed by the authorised personnel or by an authorised Service Center.
- Do not wash the machine with direct or pressurised water jets, or with corrosive substances.
- The machine must be disposed of properly, because of the presence of toxic-harmful materials (batteries, etc.), which are subject to standards that require disposal in special centres (see Scrapping chapter).

Machine Transportation



Warning! *Before transporting the machine, make sure that:*

All covers are closed.

The recovery tank and the detergent tank are empty.

The battery is disconnected.

The machine is securely fastened to the means of transport.

Machine Nomenclature (know your machine)

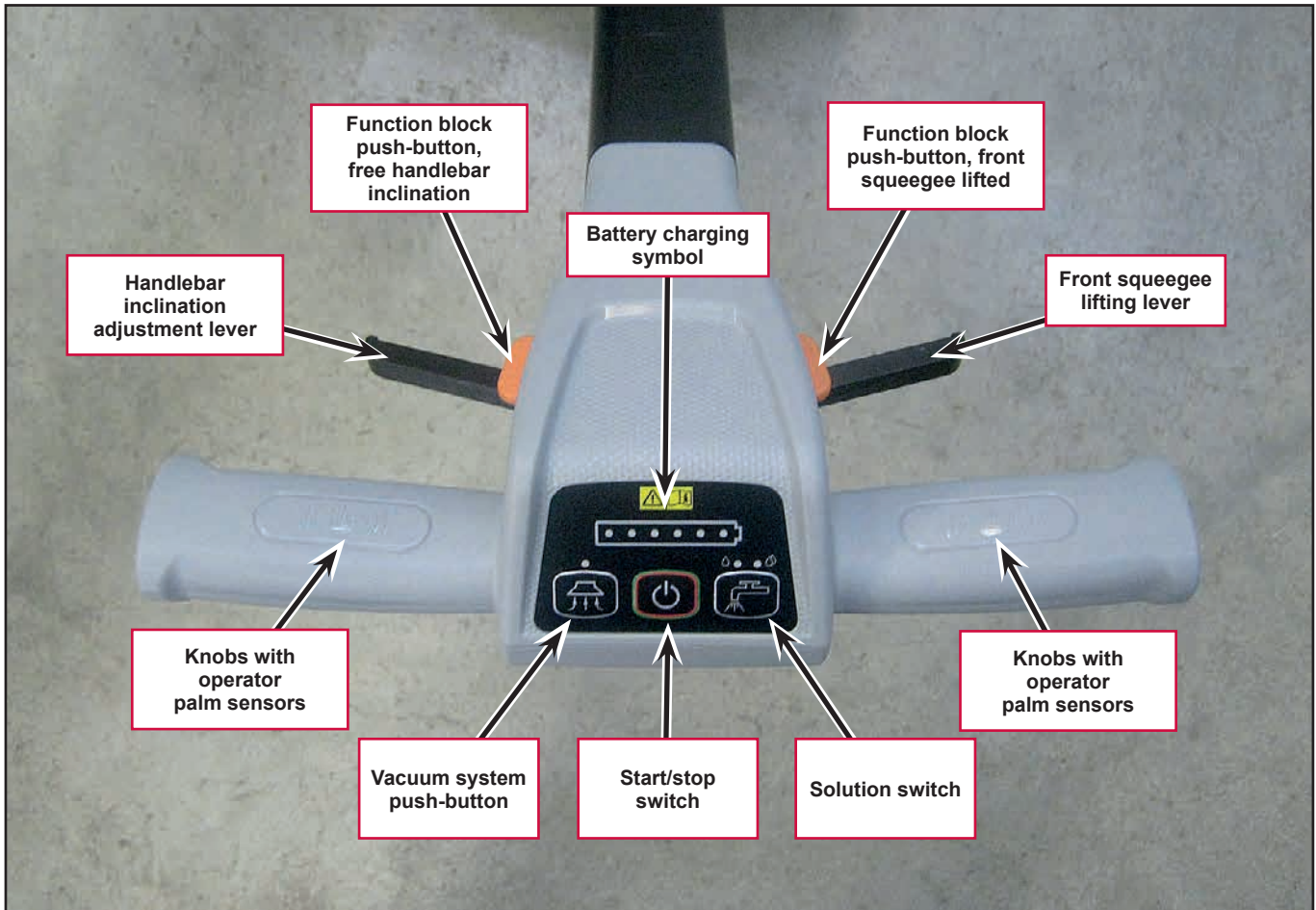

Figure 2

Machine Nomenclature (Continues)

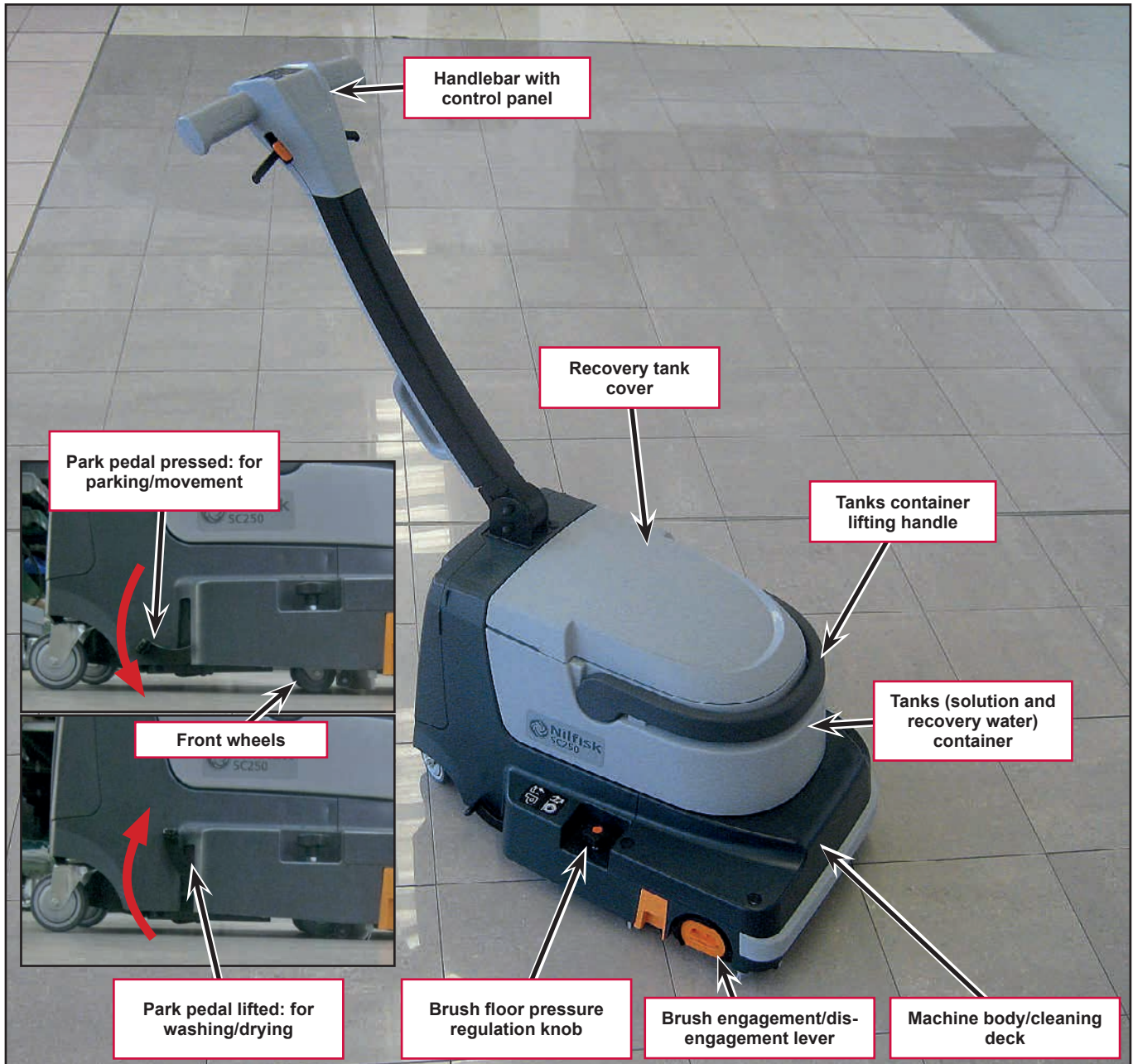

Figure 3

Machine Nomenclature (Continues)

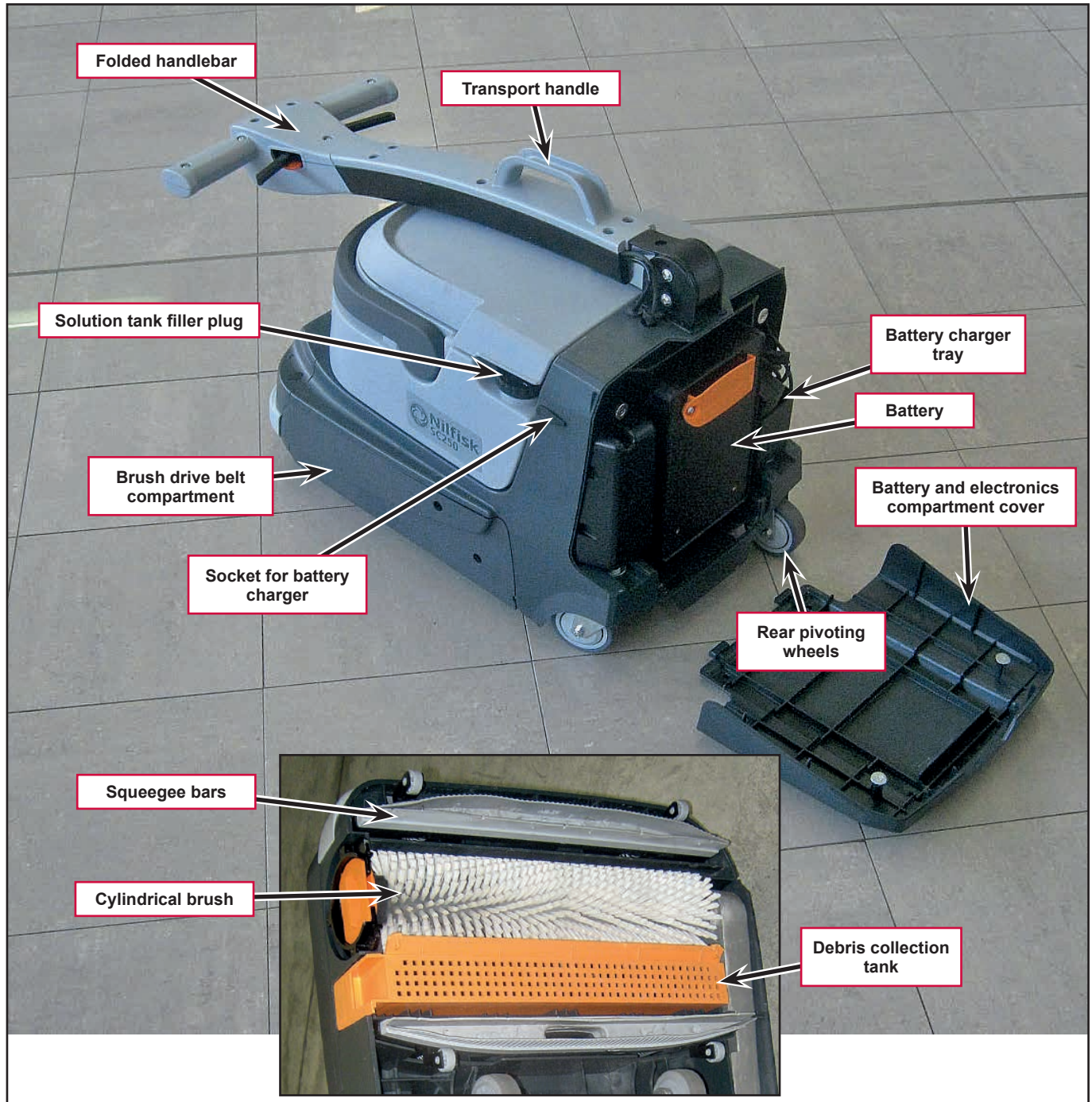

Figure 4

Service and Diagnostic Equipment

Besides a complete set of standard meters, the following instruments are necessary to perform fast checks and repairs on Nilfisk-Advance machines:

- Laptop computer charged with the current version of EzParts, Adobe Reader and (if possible) Internet connection
- Digital Volt Meter (DVM)
- Amp clamp with possibility of making DC measurements
- Hydrometer
- Battery charge tester to check 36V batteries
- Anti-static wrist strap
- Dynamometric wrench set
- A copy of the User Manual and Spare Parts List of the machine to be serviced (provided with the machine or available at www.advance-us.com or other Nilfisk websites).

The following equipment is also available at Nilfisk-Advance Centers:

- Vacuum water lift gauge, P/N 56205281

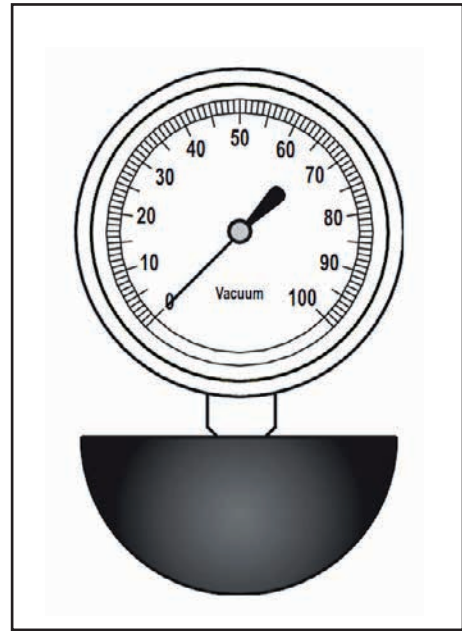

Figure 5

Technical Data

Description / Model		Advance SC250 / Clarke MA 30 / Nilfisk SC250, Scrubtec 334
Solution tank capacity		1.6 US gal (6 liters)
Recovery tank capacity		1.6 US gal (6 liters)
Machine dimensions	Length	25 in (630 mm)
	Width	17 in (425 mm)
	Height	16 in (400 mm)
Cleaning width		13.4 in (340 mm)
Squeegee width		14 in (360 mm)
Rear rotating wheel diameter		3 in (75 mm)
Front wheel diameter		2 in (50 mm)
Cylindrical brush diameter		3 in (80 mm)
Brush pressure on the ground		Max 26 lb (Max 12 Kg)
Min/max solution flow		0.04 / 0.08 US gal/min (0.15 / 0.3 L/min)
Sound pressure level at workstation (ISO 11201, ISO 4871, EN 60335-2-72) (LpA)		66 dB(A) ± 3 dB(A)
Machine sound power level (ISO 3744, ISO 4871, EN 60335-2-72) (LwA)		83 dB(A)
Vibration level at the operator's arms (ISO 5349-1, EN 60335-2-72)		< 98 in/s ² (< 2.5 m/s ²)
Maximum gradient when working		2%
Vacuum system motor power		0.24 hp (180 W)
Vacuum system capacity		2.13 ft H ₂ O (650 mm H ₂ O)
Brush motor power		0.24 hp (180 W)
Brush rotation speed		1,000 rpm
Total power draw (EN 60335-2-72)		8.5 A (0.3 kW)
IP protection class		X4
Protection class (electric)		III
Electrical system voltage		36Vdc
Standard battery		Lithium Ion - 36Vdc 8Ah
Battery charger output		42Vdc 1÷2A
Operating time (EN 60335-2-72)		40 min
Weight with empty tanks		55 lb (25 kg)
Gross vehicle weight (GVW)		71 lb (32 kg)
Shipping weight		66 lb (30 kg)

Dimensions

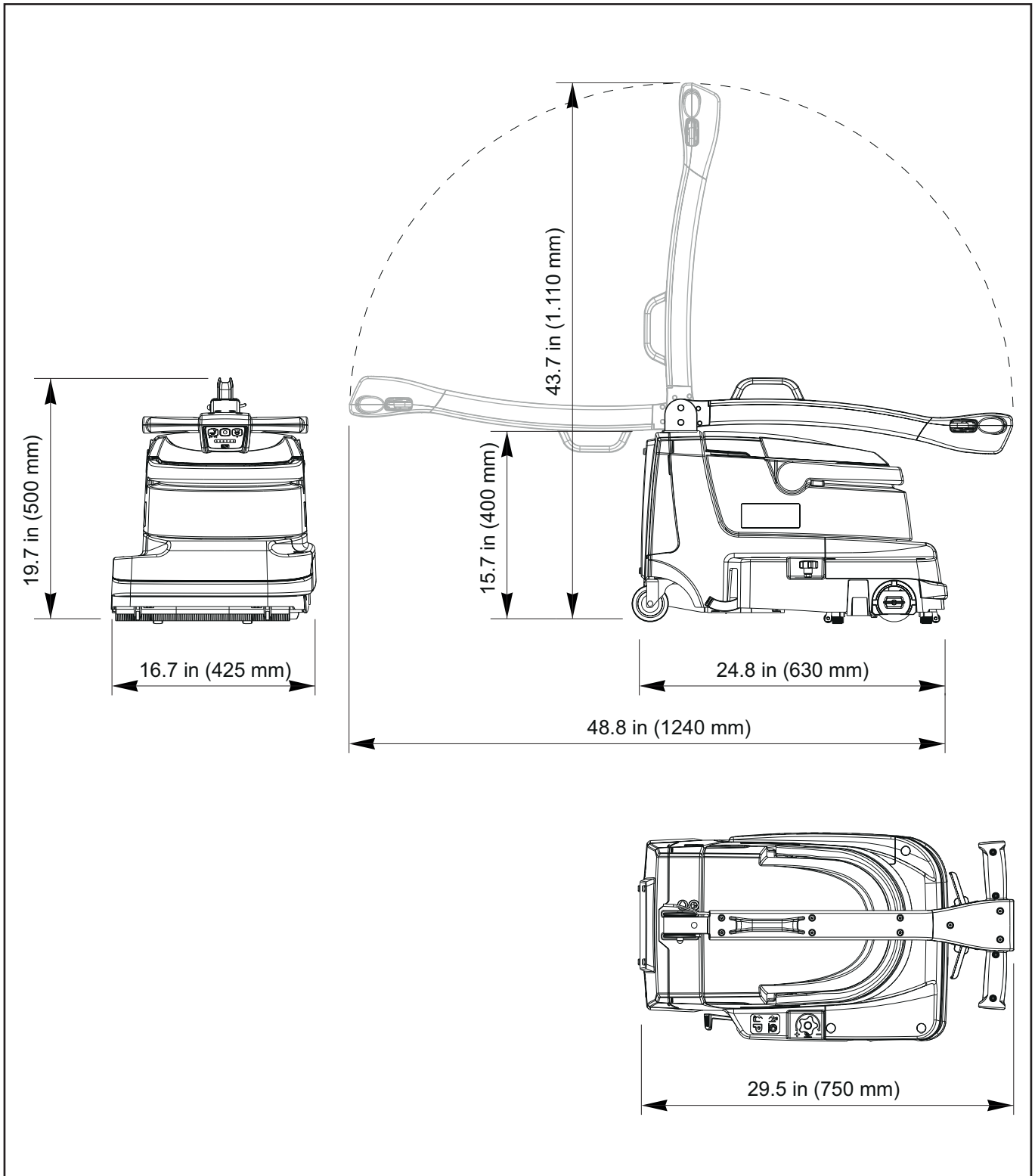

Figure 6

Maintenance

The lifespan of the machine and its maximum operating safety are ensured by correct and regular maintenance.



Warning! *Read carefully the instructions in the Safety chapter before performing any maintenance procedure.*

The following tables provides the scheduled maintenance. The intervals shown may vary according to particular working conditions, which are to be defined by the person in charge of the maintenance.

For instructions on maintenance procedures, see the following chapters.

Scheduled Maintenance Table

Procedure	Daily, after using the machine	Weekly	Every six months
Battery charging			
Squeegee bar cleaning			
Brush Cleaning			
Cleaning of the brush compartment and the debris collection grid			
Recovery tank and solution tank rinsing			
Cleaning of intake duct			
Cleaning of the solution dispensers			
Squeegee blades check			
Detergent filter cleaning			
Cleaning of the air filter and gaskets			
Squeegee bar replacement			

04 - Control System

Functional Description

The (electrical) functions of the machine are controlled via the handlebar with the 3 buttons on the Main control board (EB2) and activation of the hand presence sensors (S1 - S2) inside the grip handles (the position of these is indicated by the corresponding icons).

The machine is turned on and off by pressing the on/off push-button



When the machine is turned on, the scrub, solution flow (at level 1) and vacuum functions are activated automatically. Brush rotation and the activation of the pump, however, also require the activation of at least 1 of the 2 hand presence sensors.

The vacuum function can be disabled and re-enabled



via the vacuum system push-button. The corresponding green LED provides the operator with information on the status of the function.

The solution flow can be increased with 2 levels



The corresponding green LEDs provide the operator with information on the status of the function.

The battery charge level is displayed using the 6 green



LEDs inside the battery symbol

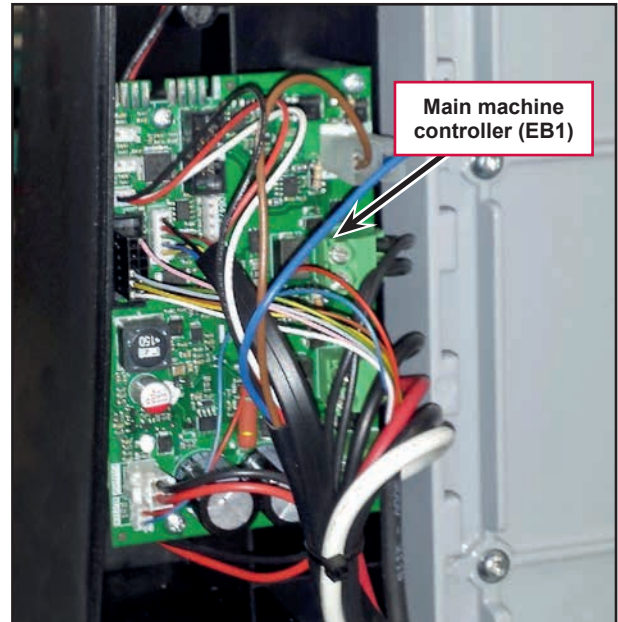

Main machine controller (EB1)

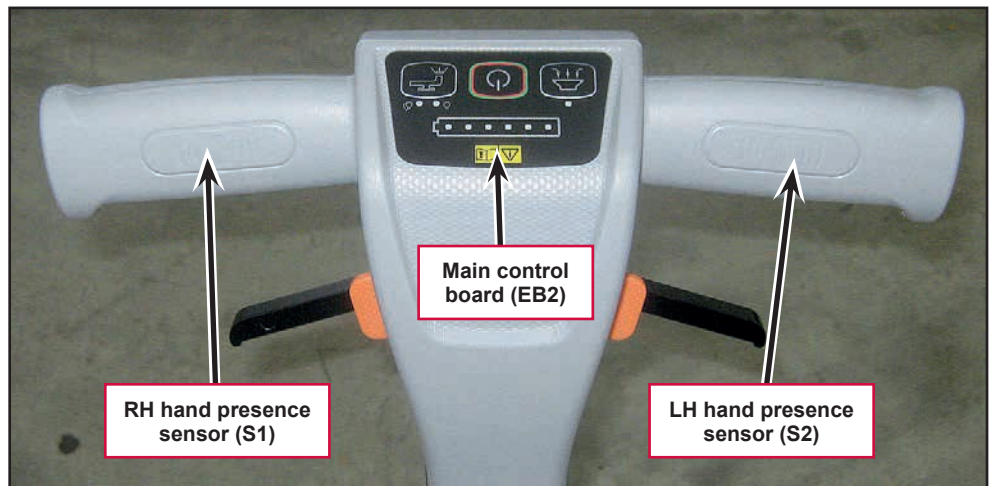

RH hand presence sensor (S1)

Main control board (EB2)

LH hand presence sensor (S2)

Wiring Diagram

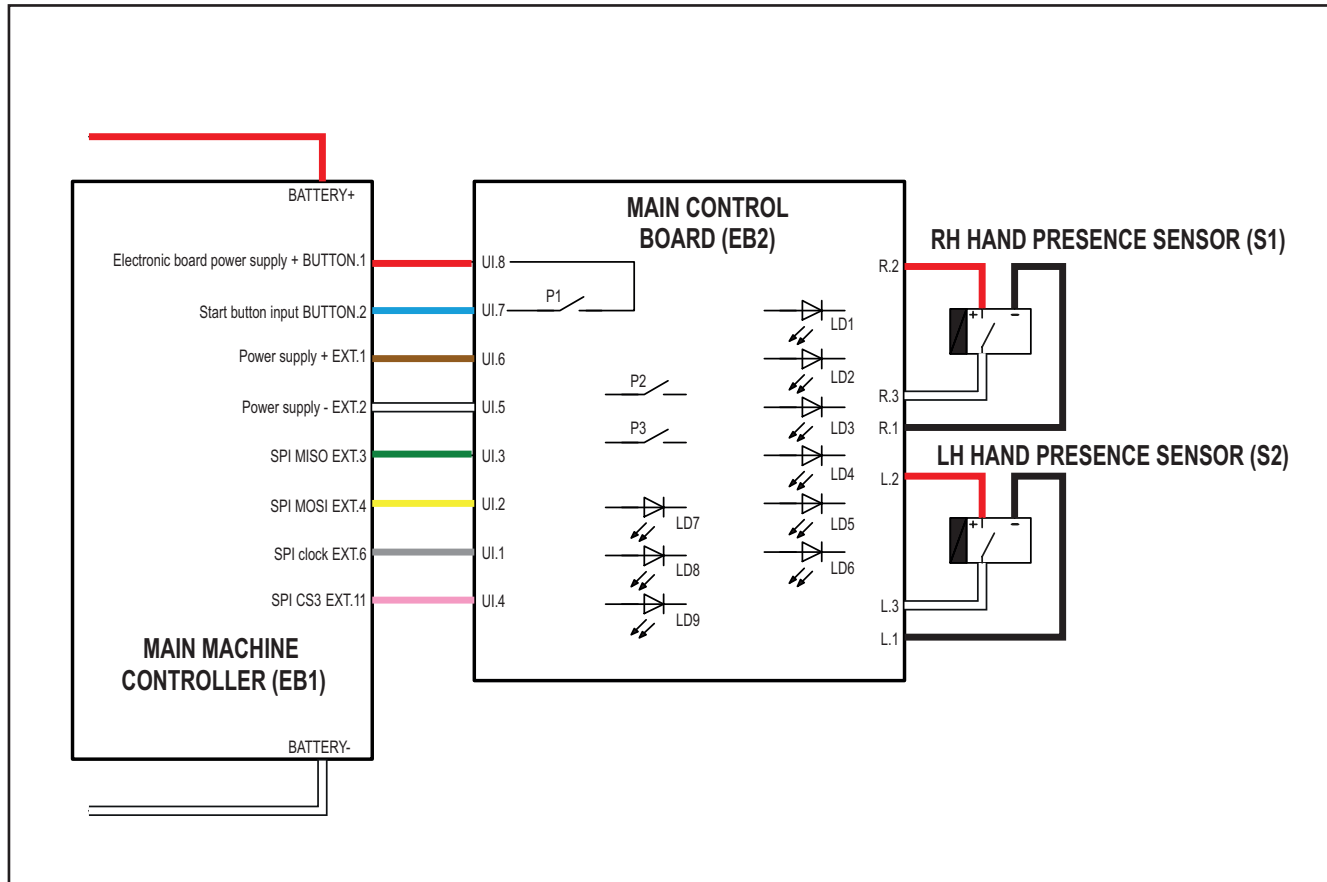

Figure 1

Component Locations

- Main machine controller (EB1)
- Main control board (EB2)
- RH hand presence sensor (S1)
- LH hand presence sensor (S2)

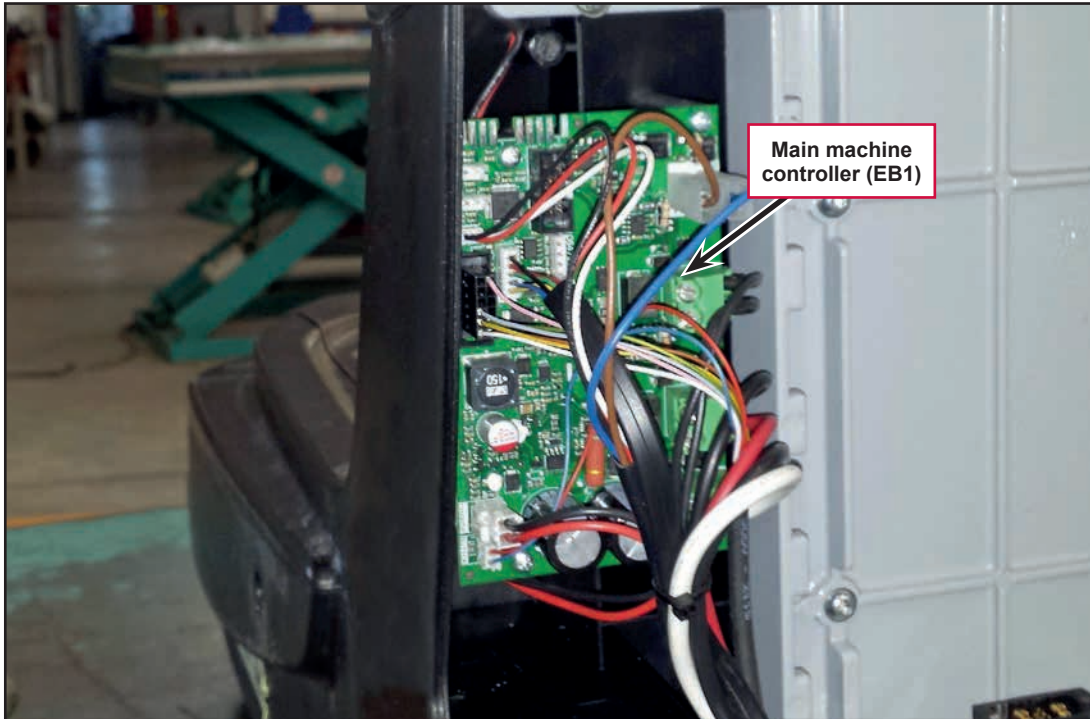

Figure 2

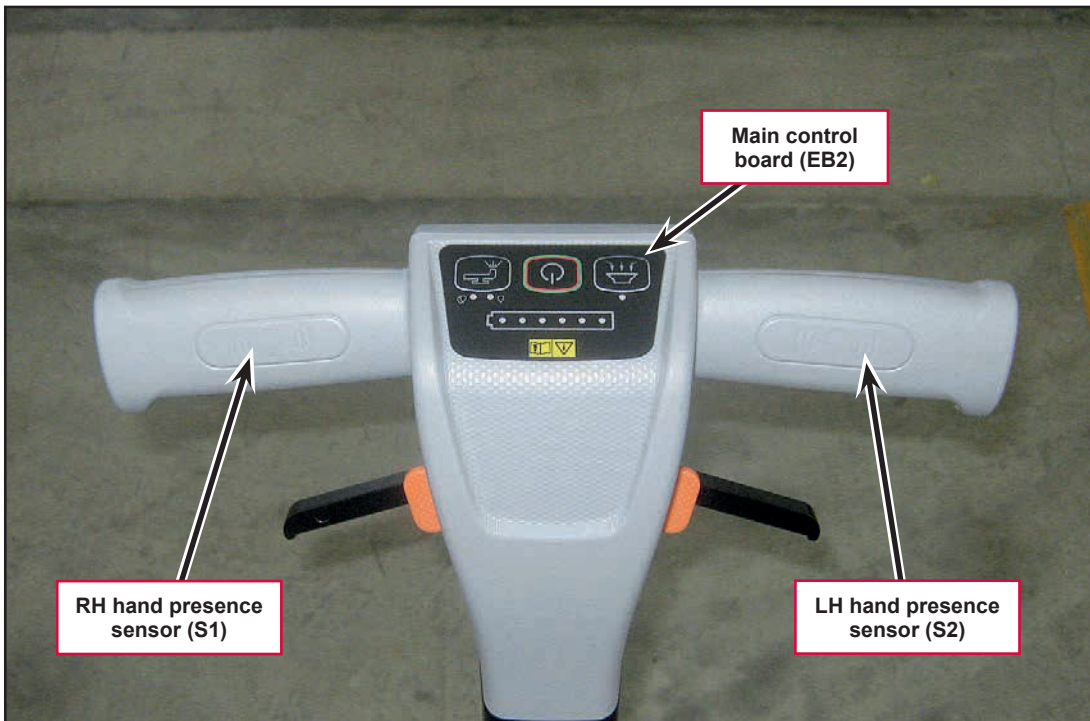

Figure 3

Removal and Installation

Main Machine Controller (EB1)



Warning! *Electrostatic sensitive device, observe precautions for handling. Use the specific ESD gloves. The operator should not wear a sweater, fleece or other wool or synthetic clothing when changing the PCB. The wrist strap must be connected to an earth ground. See the relevant instructions.*



Figure 4

Removal

1. Remove the tank assembly from the machine.
2. Open the rear cover and remove the battery.
3. Remove the screw (A) and remove the controller protective cover (B).

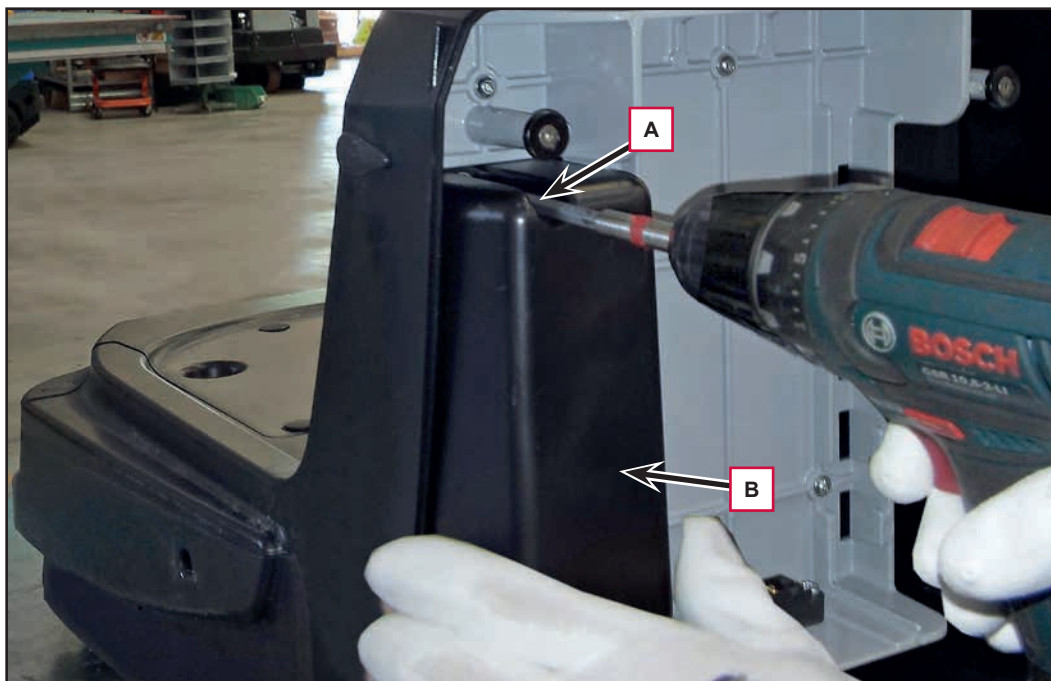

Figure 5

Main Machine Controller (EB1) (continues)

4. Disconnect the connector for the water sensor wiring (C).

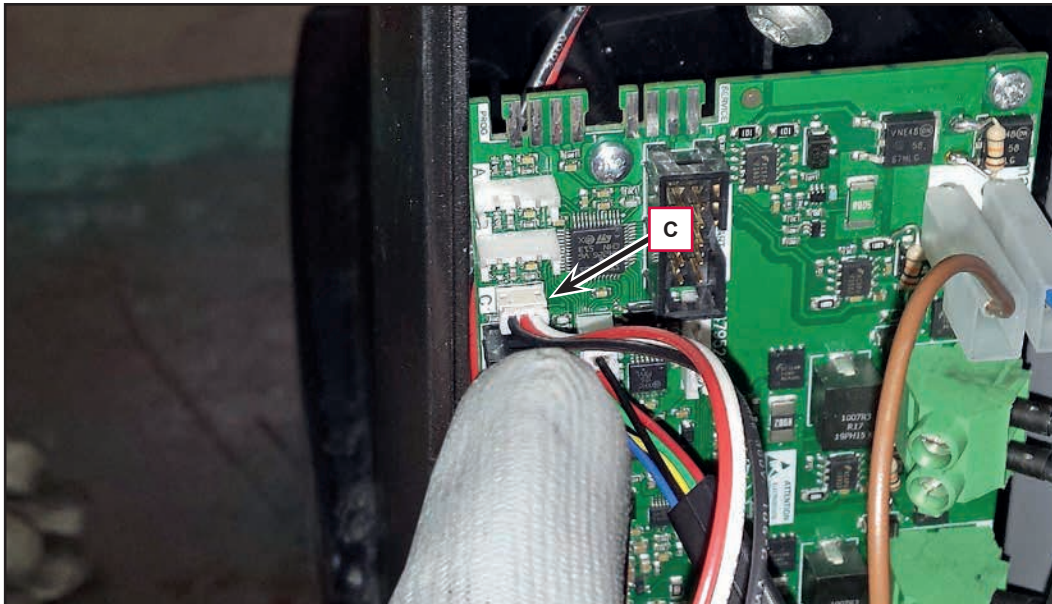

Figure 6

5. Disconnect the connector for the BMS electronic battery management wiring (D).

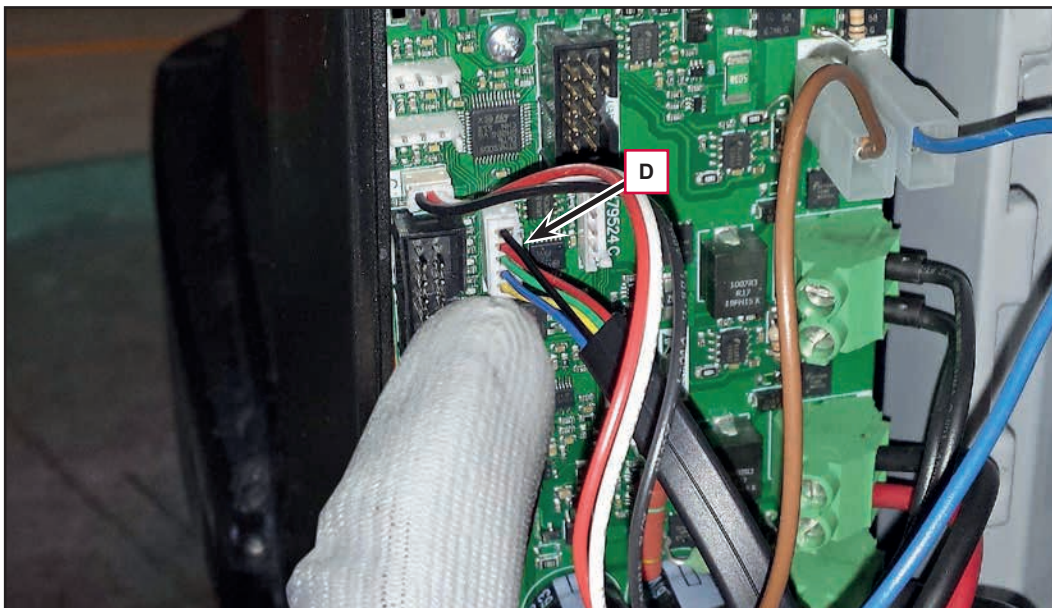

Figure 7

Main Machine Controller (EB1) (continues)

6. Disconnect the connector for the handlebar wiring (E).

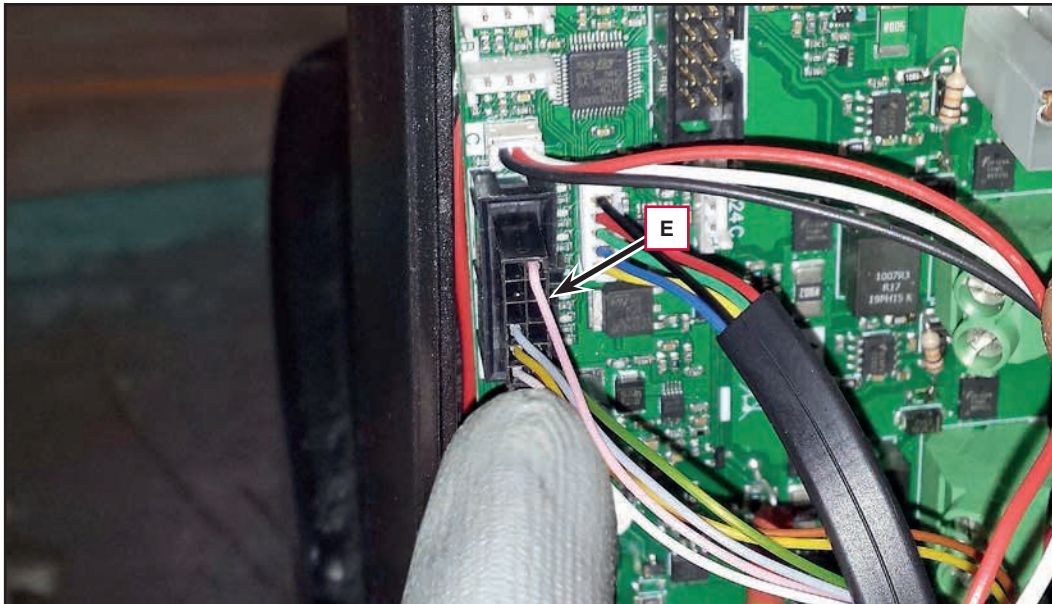

Figure 8

7. Disconnect the connector for the battery charger wiring (F).

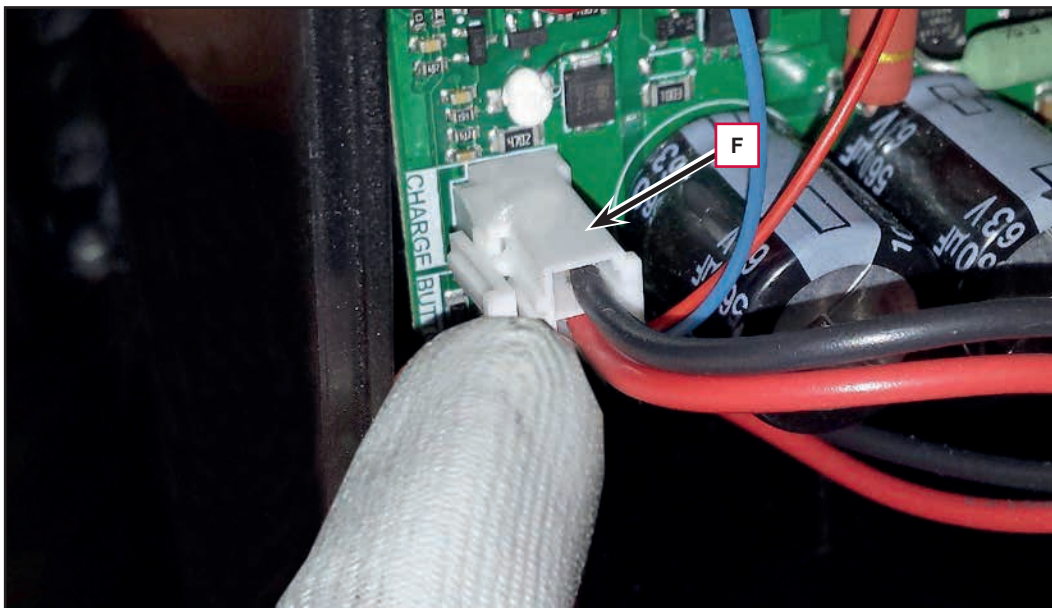

Figure 9

Main Machine Controller (EB1) (continues)

8. Disconnect the connector for the on button wiring (G).

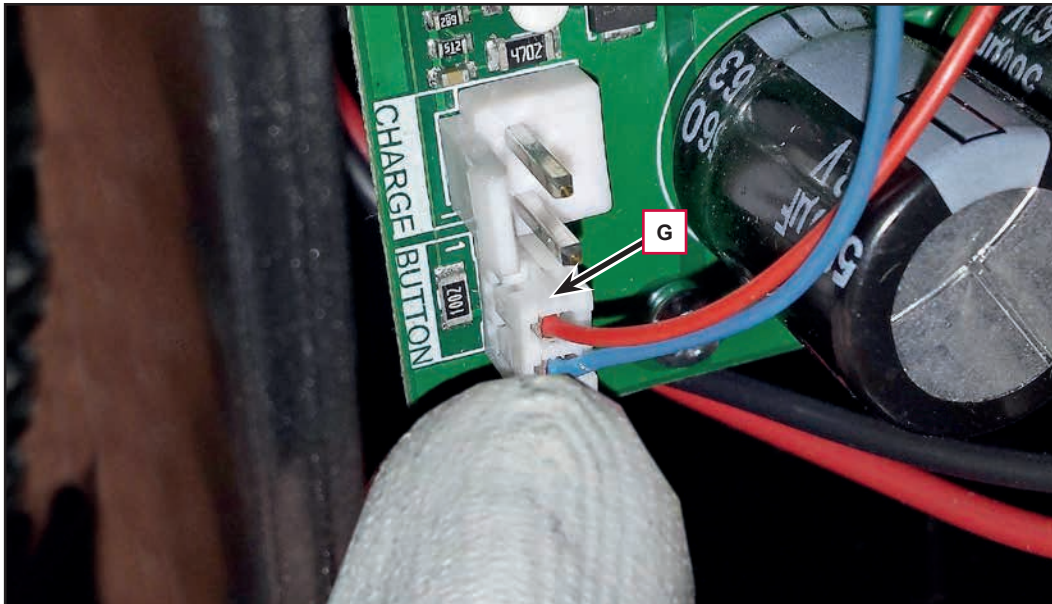

Figure 10

9. Disconnect the water pump connections wiring (H).

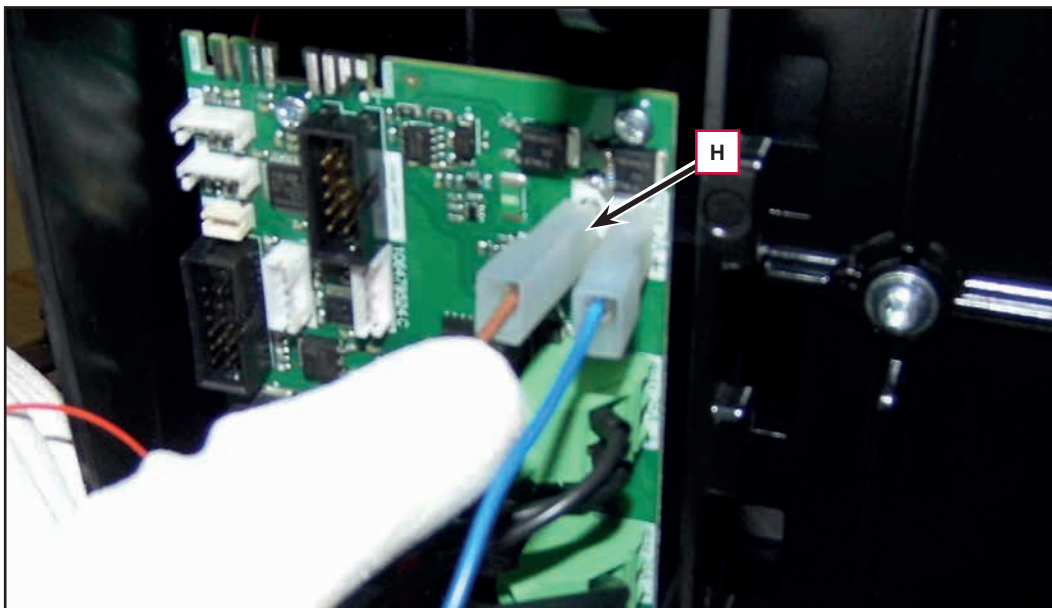

Figure 11

Main Machine Controller (EB1) (continues)

10. Disconnect the vacuum motor connections wiring (I).

- While you unscrew the connection fastening screws, use a pair of pliers to hold the connector on the controller (when tighten the screw, use a tightening torque to a 0,4 Nm).

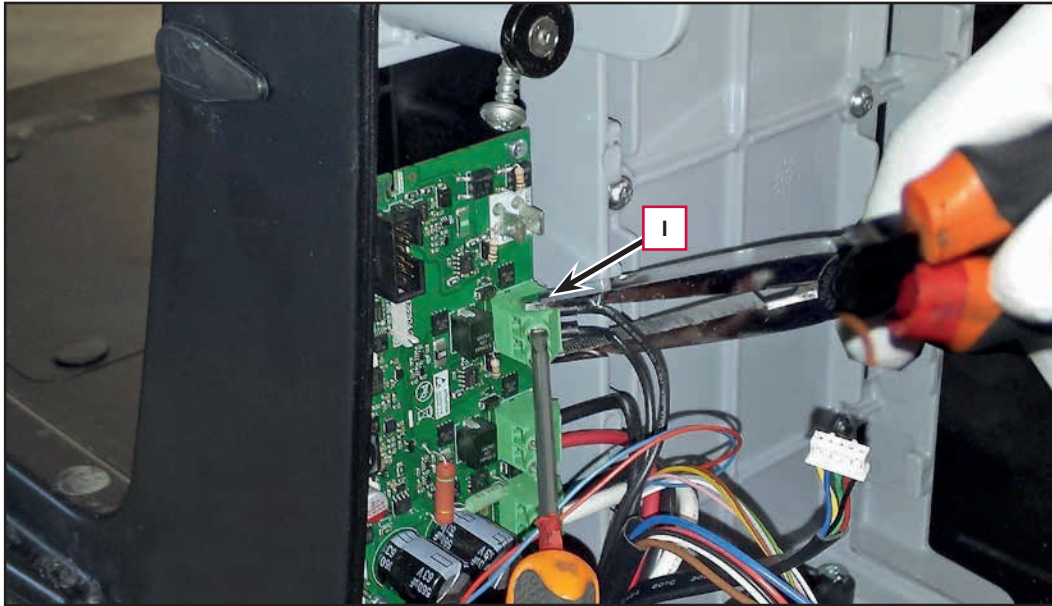

Figure 12

11. Disconnect the brush motor connections wiring (J).

- While you unscrew the connection fastening screws, use a pair of pliers to hold the connector on the controller (when tighten the screw, use a tightening torque to a 0,4 Nm).

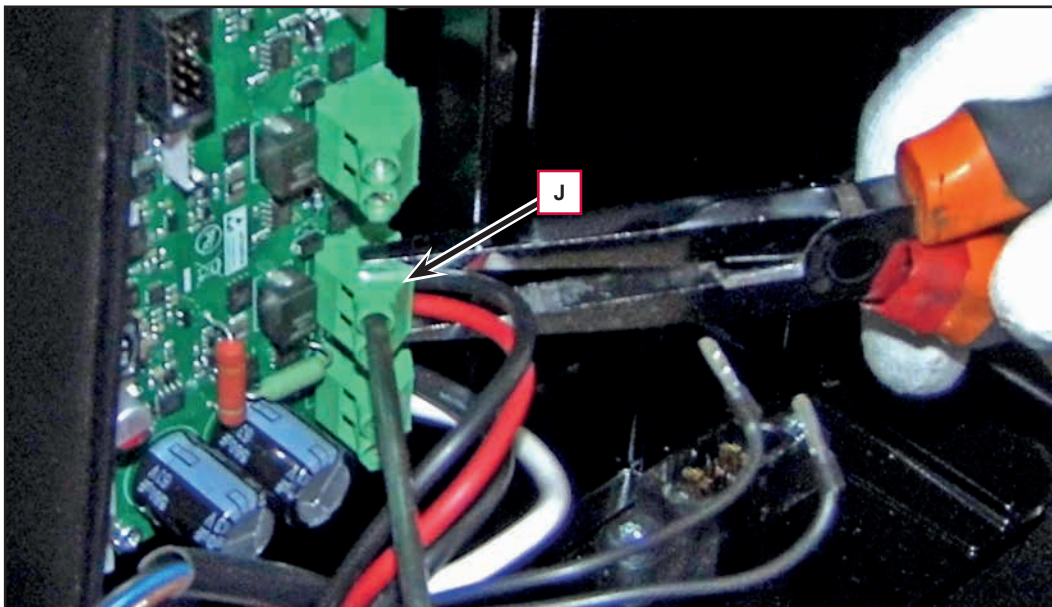

Figure 13

Main Machine Controller (EB1) (continues)

12. Disconnect the power supply connections wiring (K).

- While you unscrew the connection fastening screws, use a pair of pliers to hold the connector on the controller (when tighten the screw, use a tightening torque to a 0,4 Nm).

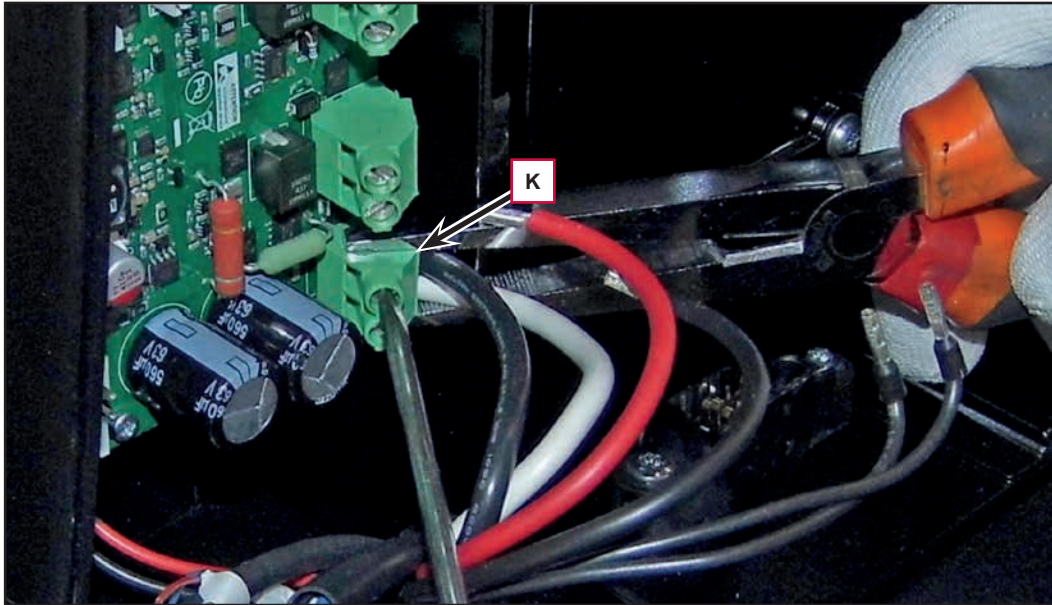

Figure 14

13. Remove the screws (L), then remove the main machine controller (when mounting, tighten the screws with a tightening torque to a 0,8 Nm).

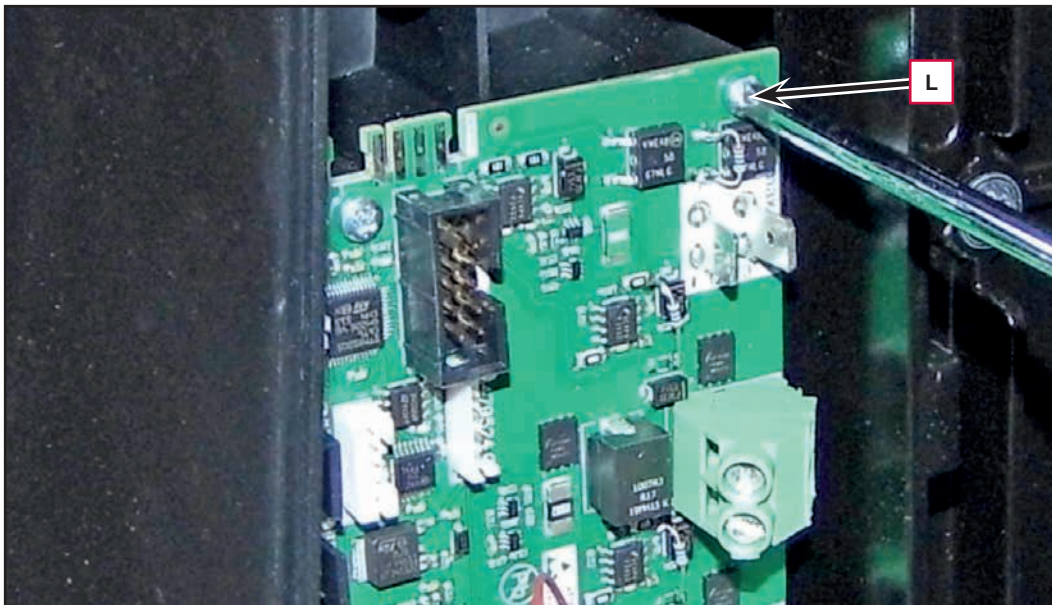

Figure 15

Installation

14. Assemble the components in the reverse order of disassembly.

Main Control Board (EB2) and Hand Presence Sensors (S1, S2)

Main Control Board Removal

1. Open the rear cover and remove the battery.
2. Lower the handlebar and move it forwards by pressing the left lever.
3. Remove the 7 screws (A) and remove the lower cover (B).

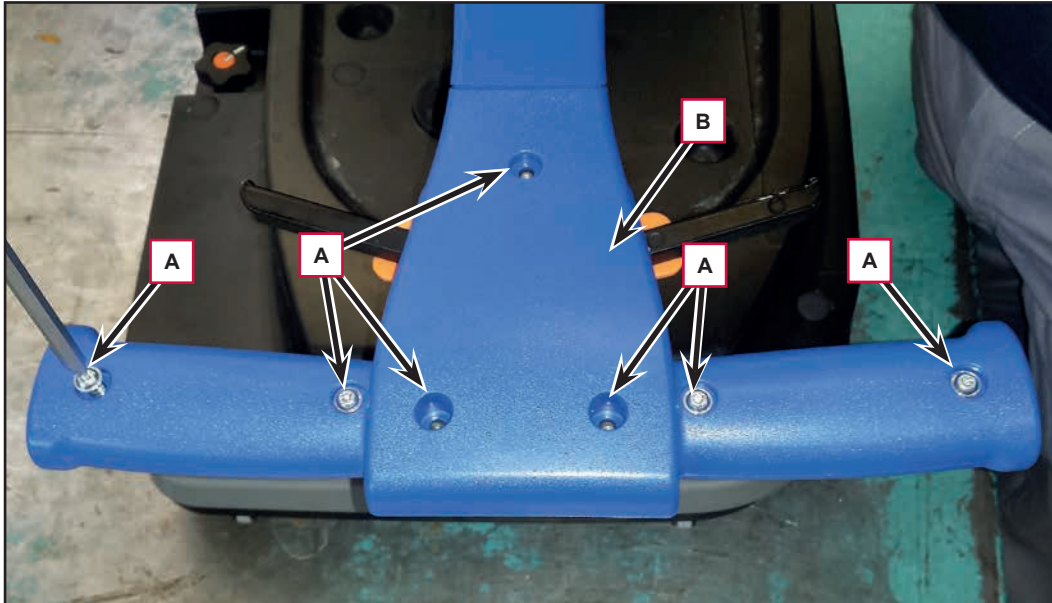

Figure 16

4. Remove the 3 upper cover (D) fastening screws (C).

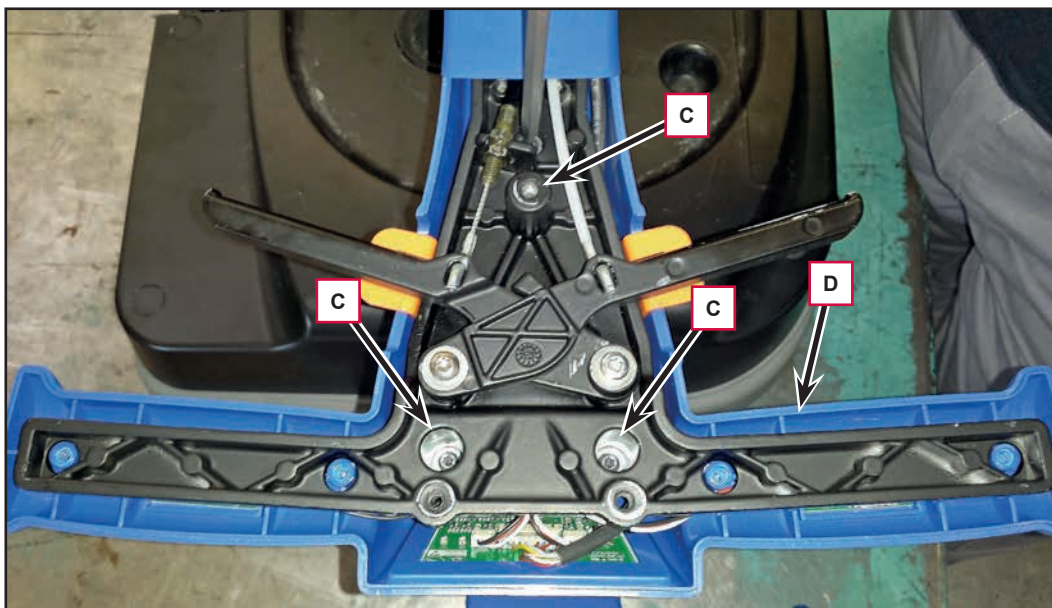

Figure 17

Main Control Board (EB2) and Hand Presence Sensors (S1, S2) (continues)

5. Unscrew the screw (E) holding the main control board wiring (F).

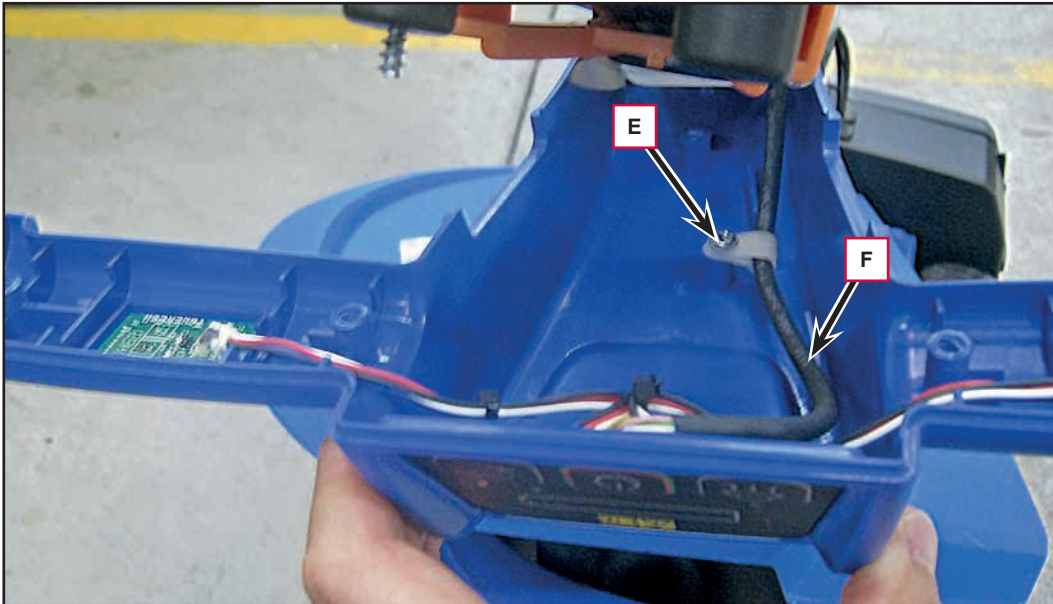

Figure 18

6. Disconnect the main wiring (G) and the 2 connections for the hand presence sensors (H).

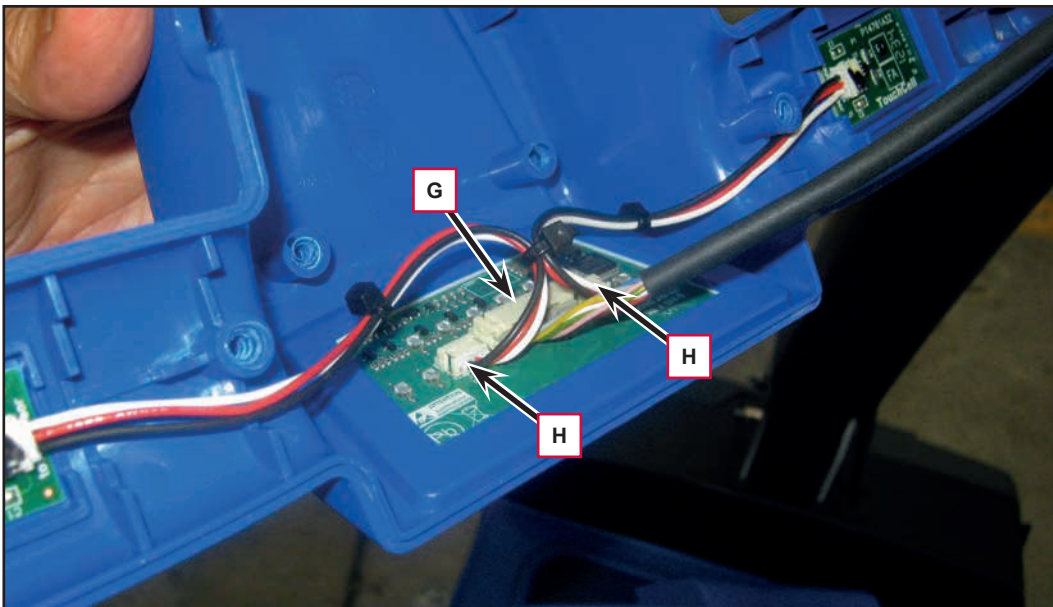

Figure 19

Main Control Board (EB2) and Hand Presence Sensors (S1, S2) (continues)

- Carefully remove the main control board (I), detaching it from its seat on the front cover (J).

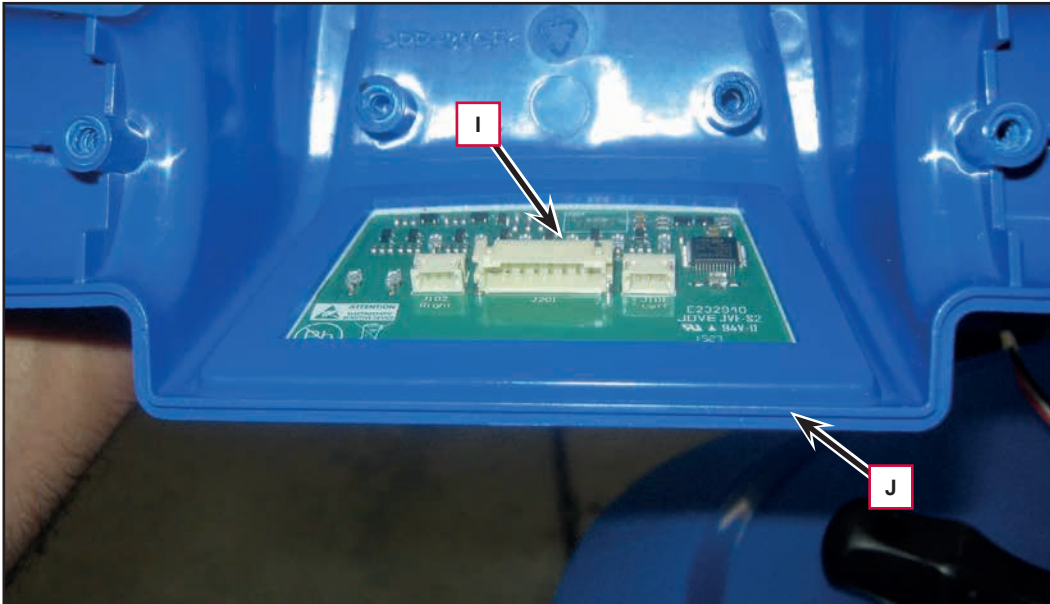

Figure 20

Hand presence Sensors (S1, S2) Removal

- Disconnect the 2 connections wiring (K) from the hand presence sensors (L).

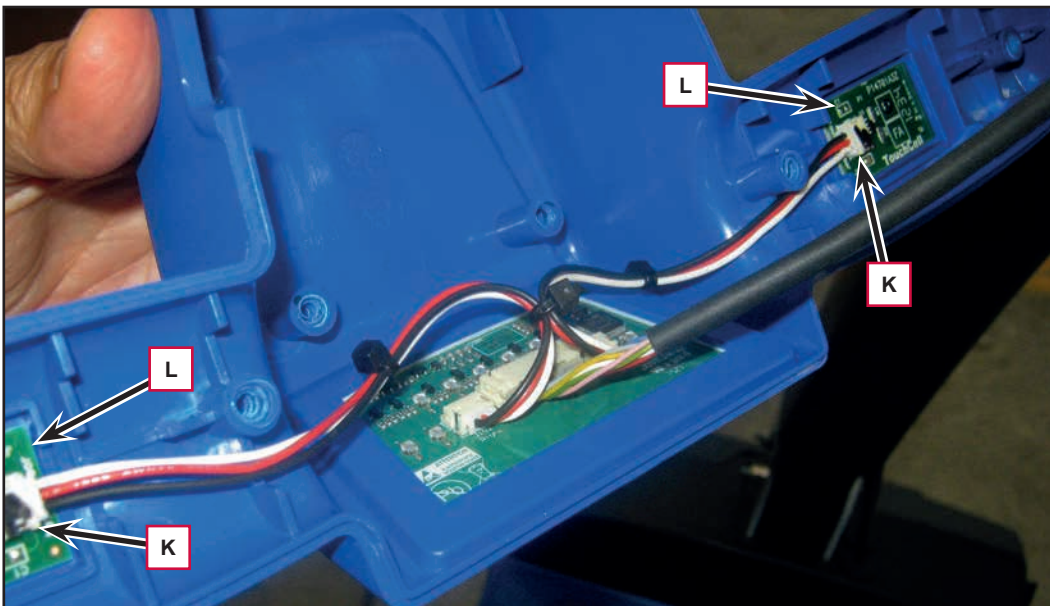

Figure 21

Main Control Board (EB2) and Hand Presence Sensors (S1, S2) (continues)

- Carefully remove the sensors (L), detaching them from their seat on the grip handles (N).

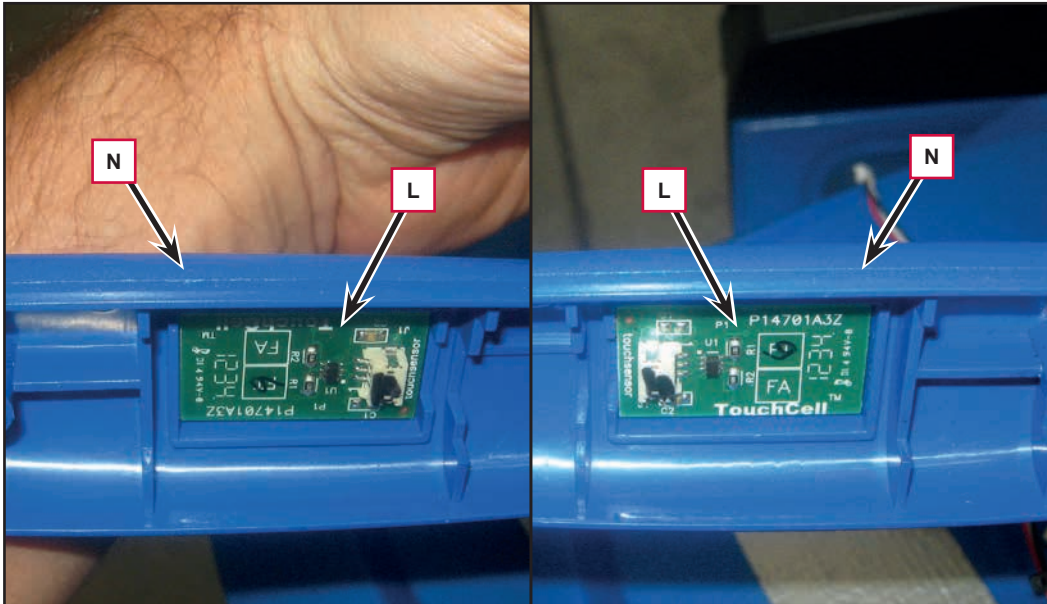

Figure 22

Installation

- Assemble the components in the reverse order of disassembly.

Specifications

Main Machine Controller (EB1) Connectors

BATTERY: type FCI T702035100J0G (2 ways, screw type)					
PIN	Description	El. board in/out	V ref.	I max.	Connected to
1	Vbatt +	In	36V	25A	BAT+
2	Vbatt -	In	0V	25A	BAT-

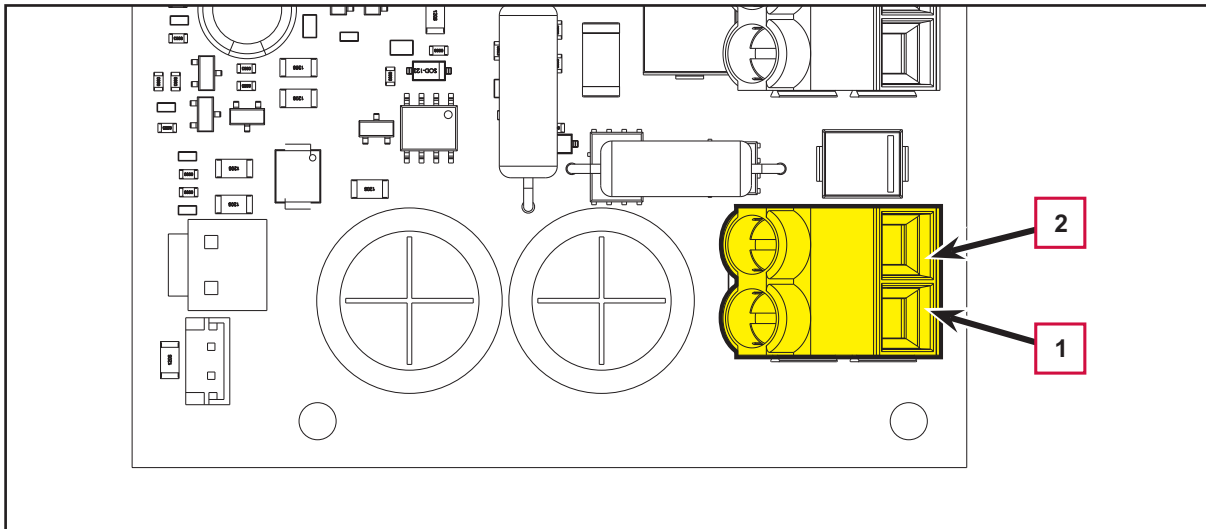

Figure 23

OUT1: type FCI T702035100J0G (2 ways, screw type)					
PIN	Description	El. board in/out	V ref.	I max.	Connected to
1	Brush motor output +	Out	36V	20A	M1+
2	Brush motor output -	Out	0V	20A	M1-

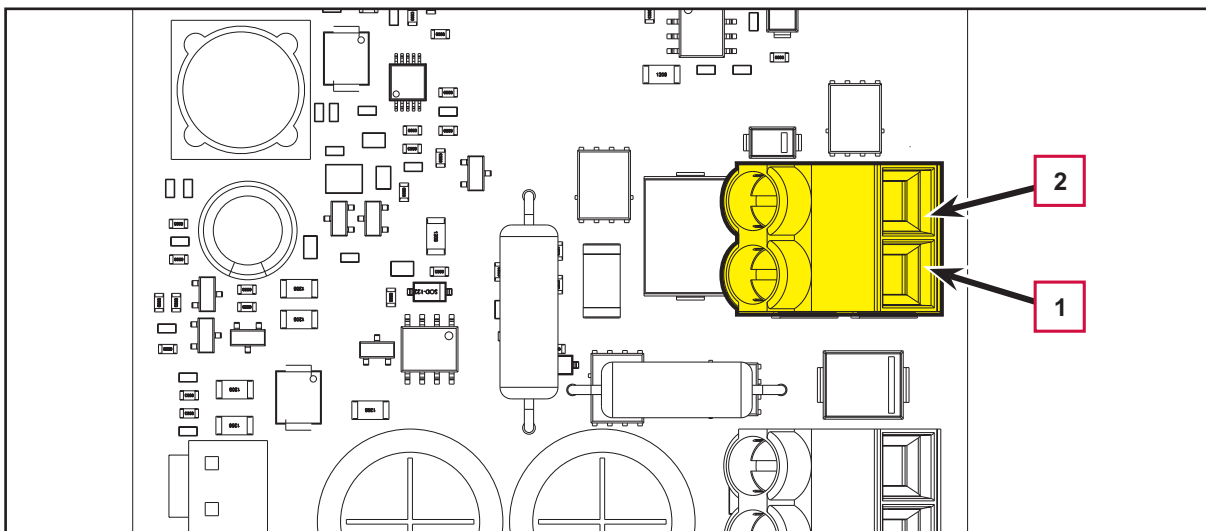

Figure 24

Main Machine Controller (EB1) Connectors (continues)

OUT2: type FCI T702035100J0G (2 ways, screw type)					
PIN	Description	El. board in/out	V ref.	I max.	Connected to
1	Vacuum motor output +	Out	36V	20A	M2+
2	Vacuum motor output -	Out	0V	20A	M2-

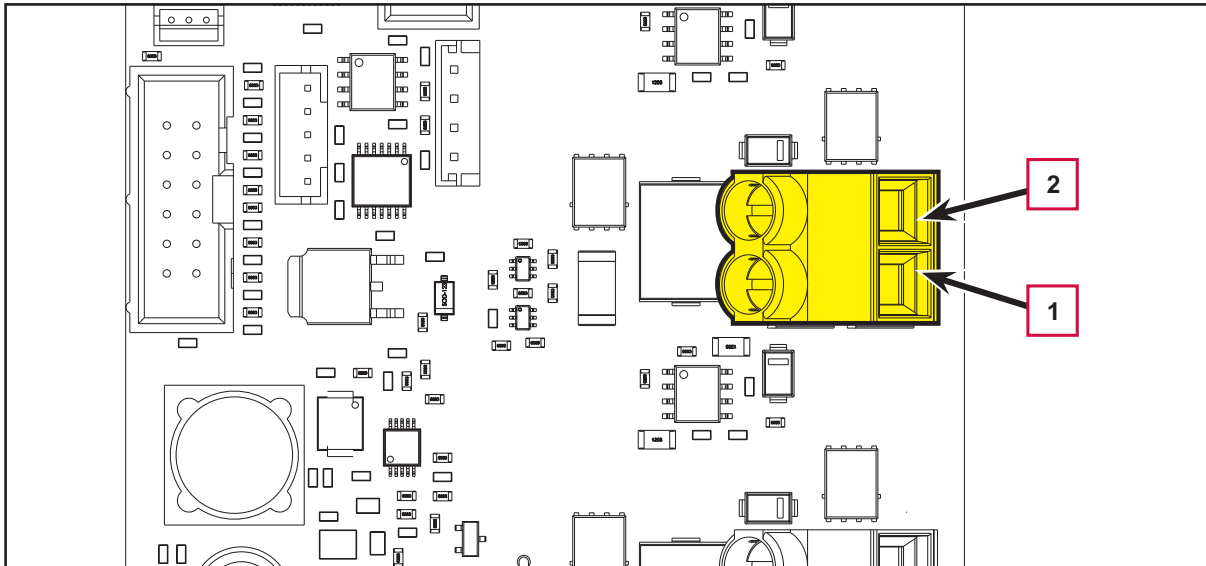

Figure 25

OUT3: faston 6.3x0.8mm (2 ways, vertical)					
PIN	Description	El. board in/out	V ref.	I max.	Connected to
1	Water pump output +	Out	24V	2A	PM+
2	Water pump output -	Out	0V	2A	PM-

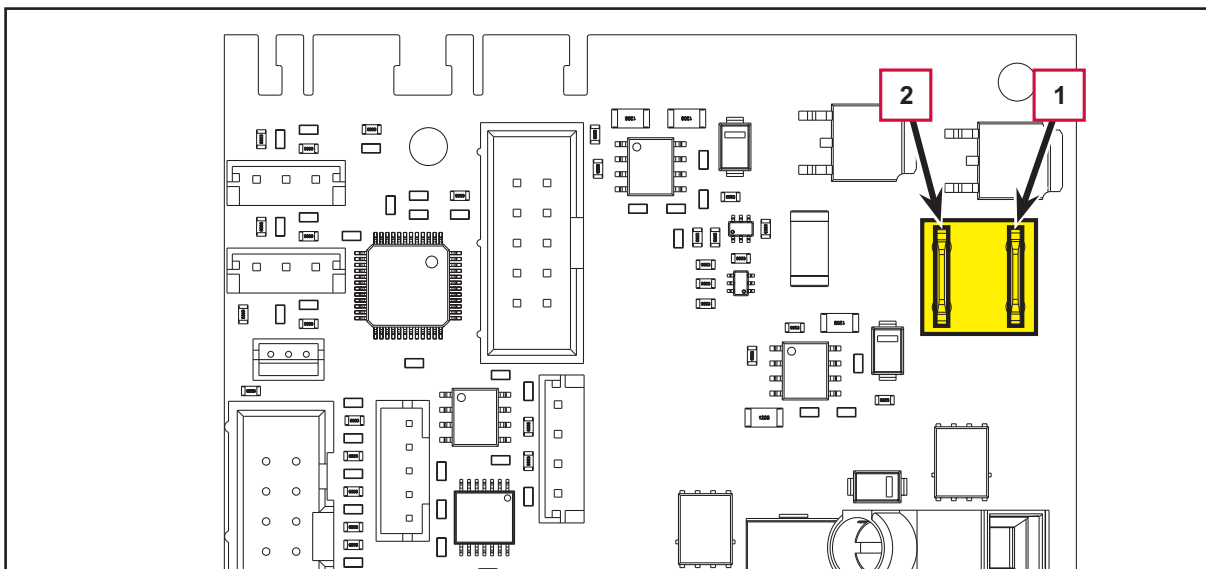

Figure 26

Main Machine Controller (EB1) Connectors (continues)

CHARGE: JST B2P-VH(LF)(SN) (2 ways, vertical)					
PIN	Description	El. board in/out	V ref.	I max.	Connected to
1	Battery charger input +	In	36V	2A	CH+
2	Battery charger input -	In	0V	2A	CH-

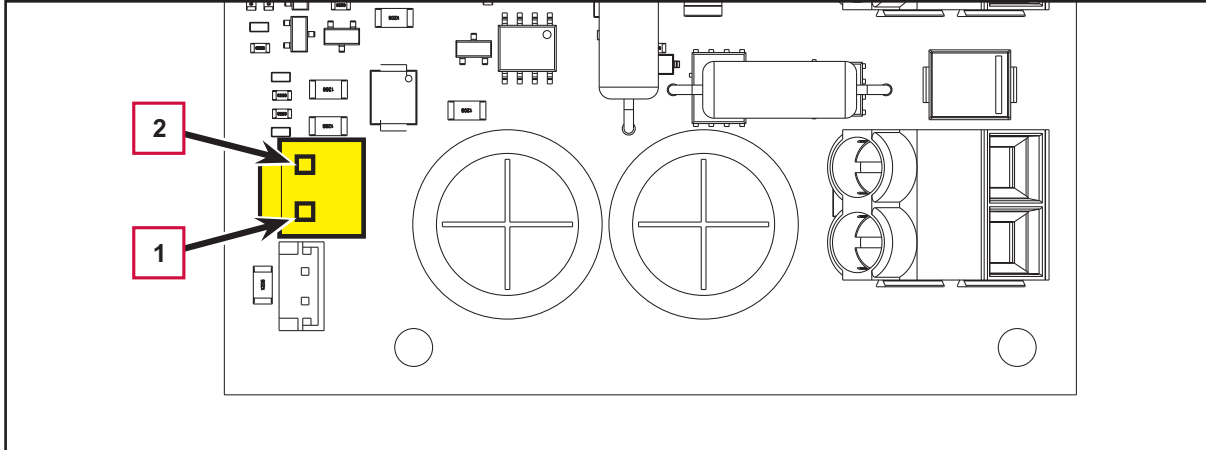

Figure 27

BATT: JST B5B-PH-K-S (5 ways, vertical)					
PIN	Description	El. board in/out	V ref.	I max.	Connected to
1	Battery LED input - strobe	In	0-3.3V	<1A	BAT.A1
2	Battery LED input - clock	In	0-3.3V	<1A	BAT.B1
3	CAN-H (not used)	In-out	0-3.3V	<1A	BAT.C1
4	CAN-L (not used)	In-out	0-3.3V	<1A	BAT.C2
5	Battery LED input - data	In	0-3.3V	<1A	BAT.B2

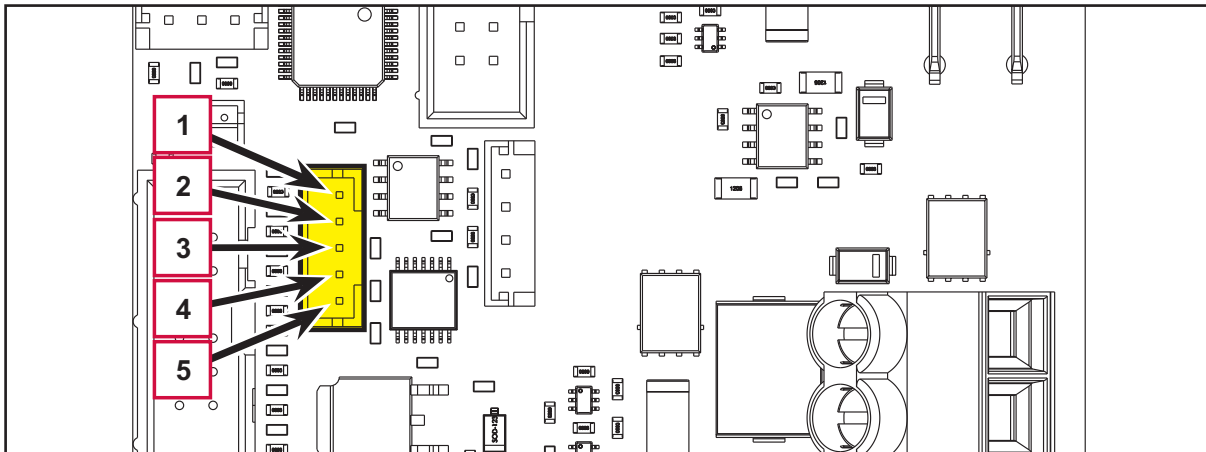

Figure 28

Main Machine Controller (EB1) Connectors (continues)

BUTTON: JST B2B-EH-A (LF)(SN) (2 ways, vertical)					
PIN	Description	El. board in/out	V ref.	I max.	Connected to
1	Power supply +	Out	36V	<1A	UI.J201.8
2	Power button input	In	36V	<1A	UI.J201.7

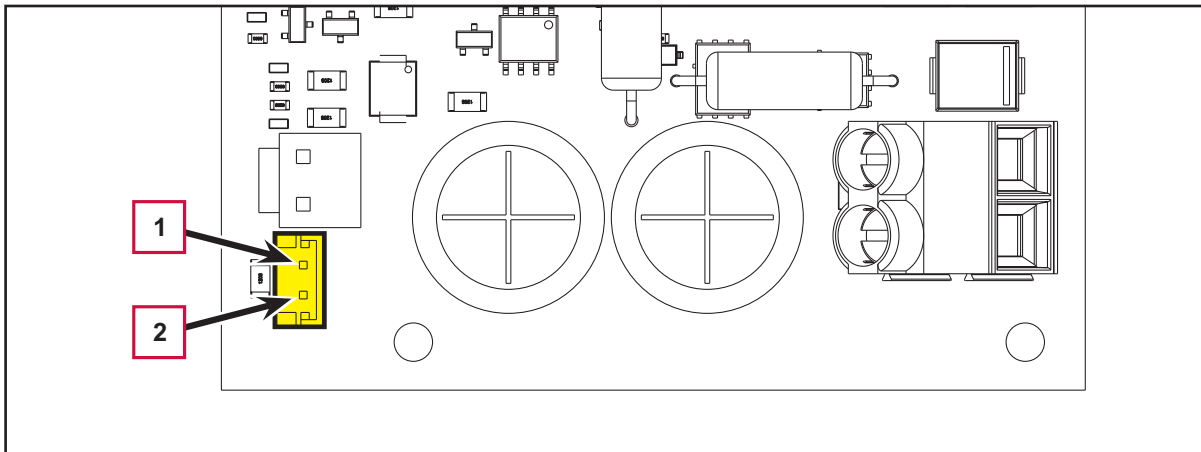

Figure 29

EXT: LEOCO 3675P12VTA0 () (12 ways, vertical)					
PIN	Description	El. board in/out	V ref.	I max.	Connected to
1	Power supply +	Out	5V	<1A	UI.J201.6
2	Power supply -	Out	0V	<1A	UI.J201.5
3	SPI MISO	In-out	0-5V	<1A	UI.J201.3
4	SPI MOSI	In-out	0-5V	<1A	UI.J201.2
5	Power supply - (not used)	Out	0V	<1A	-
6	SPI clock	Out	0-5V	<1A	UI.J201.1
7					
8	Power supply - (not used)	Out	0V	<1A	-
9					
10					
11	SPI CS3	Out	0-5V	<1A	UI.J201.4
12					

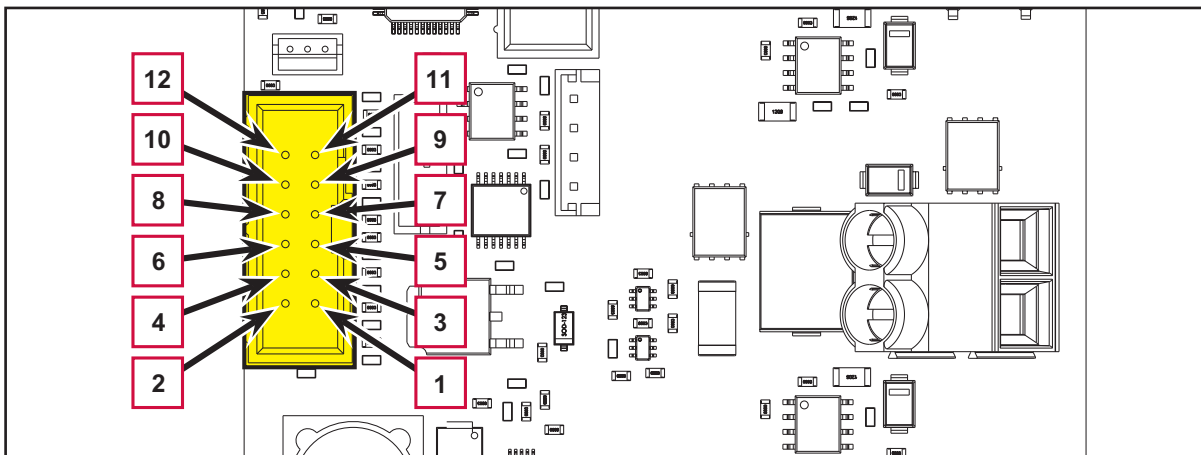

Figure 30

Main Machine Controller (EB1) Connectors (continues)

C: JST B3B-ZR(LF)(SN) (3 ways, vertical)					
PIN	Description	El. board in/out	V ref.	I max.	Connected to
1	Water sensor supply -	Out	0V	<1A	S3.1
2	Water sensor supply +	Out	5V	<1A	S3.2
3	Water sensor input	In	0V	<1A	S3.3

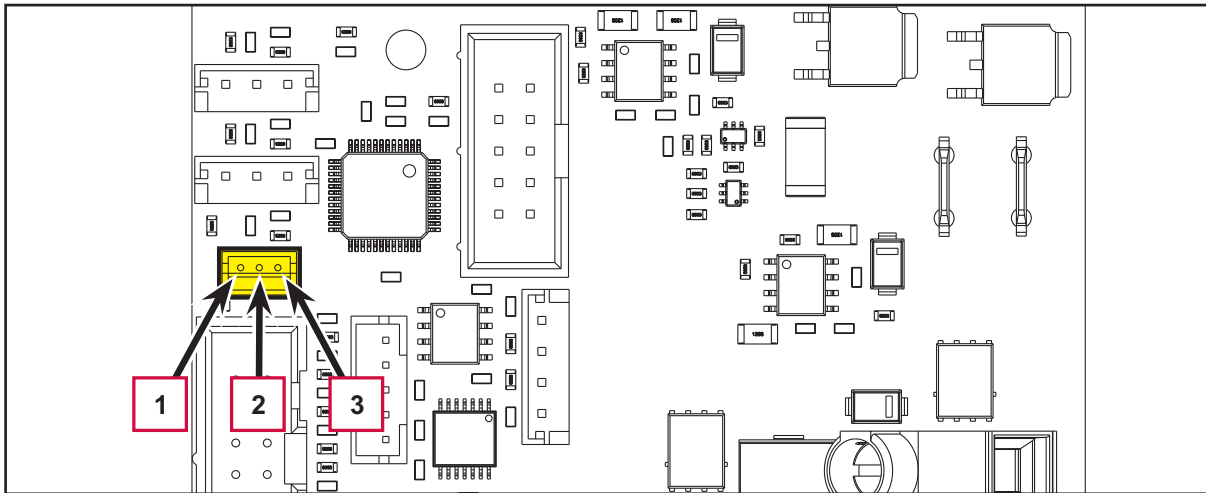

Figure 31

Main Control Board (EB2) Connectors

J201: JST S8B-PH-SM4-TB (8 ways, vertical)					
PIN	Description	El. board in/out	V ref.	I max.	Connected to
1	SPI clock	In	0-5V	<1A	EXT.6
2	SPI MOSI	In-out	0-5V	<1A	EXT.4
3	SPI MISO	In-out	0-5V	<1A	EXT.3
4	SPI CS3	In	0-5V	<1A	EXT.11
5	Power supply -	In	0V	<1A	EXT.2
6	Power supply +	In	5V	<1A	EXT.1
7	Power button input	Out	36V	<1A	BUTTON.2
8	Power supply +	In	36V	<1A	BUTTON.1

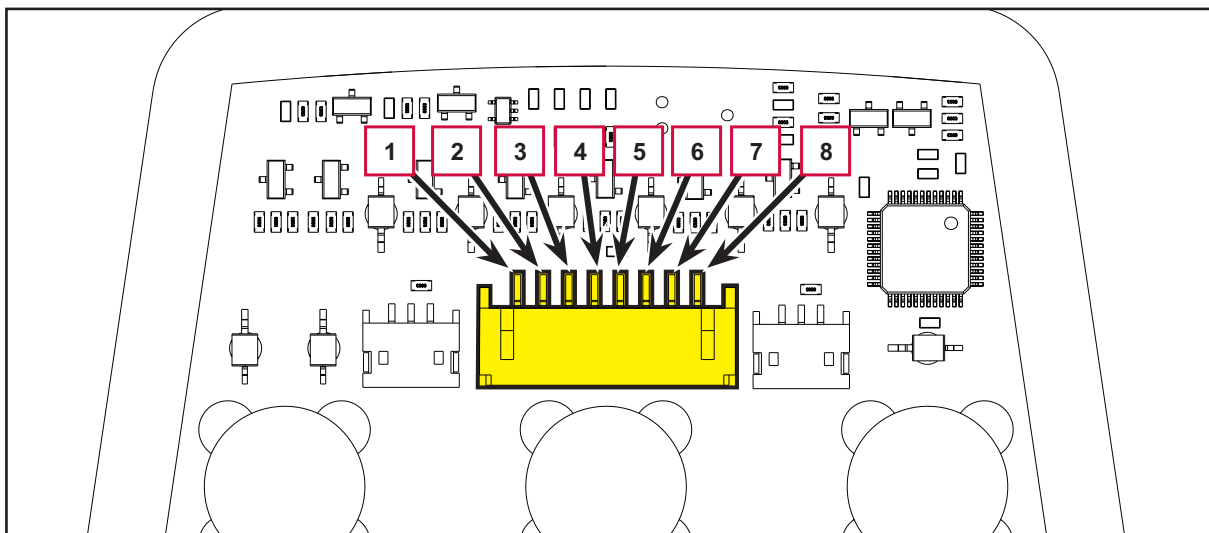

Figure 32 - (main control board - back view)

Main Control Board (EB2) Connectors (continues)

LEFT: JST S3B-ZR-SM4A-TF (3 ways, side entry)					
PIN	Description	El. board in/out	V ref.	I max.	Connected to
1	Left hand presence sensor supply -	Out	0V	<1A	S1.1
2	Left hand presence sensor supply +	Out	5V	<1A	S1.2
3	Left hand presence sensor input	In	0V	<1A	S1.3

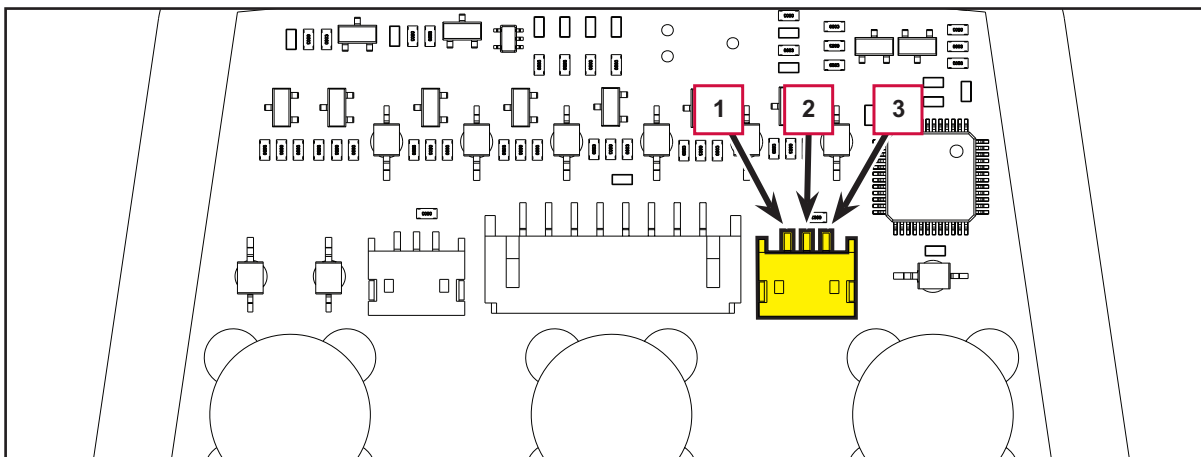

Figure 33 - (main control board - back view)

RIGHT: JST S3B-ZR-SM4A-TF (3 ways, side entry)					
PIN	Description	El. board in/out	V ref.	I max.	Connected to
1	Right hand presence sensor supply -	Out	0V	<1A	S2.1
2	Right hand presence sensor supply +	Out	5V	<1A	S2.2
3	Right hand presence sensor input	In	0V	<1A	S2.3

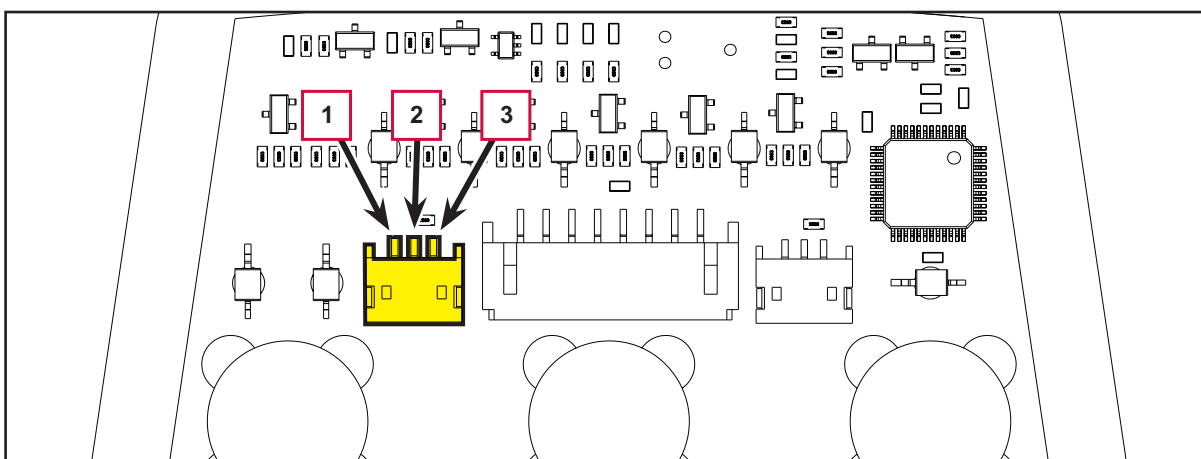

Figure 34 - (main control board - back view)

Main Control Board (EB2) Connectors (continues)

EB2 (UI) BUTTONS (on EB2 side A)

Type: 4 leg Dome 12mm Ø	
Ref.	Description
P1	Power on/off button
P2	Vacuum system button
P3	Solution flow button

EB2 (UI) LEDS (on EB2 side A)

Type: Kingbright AM2520CGCK09 or equivalent		
Ref.	Color	Description
LD1	Green	Battery level 1/6
LD2	Green	Battery level 2/6
LD3	Green	Battery level 3/6
LD4	Green	Battery level 4/6
LD5	Green	Battery level 5/6
LD6	Green	Battery level 6/6
LD7	Green	Vacuum function
LD8	Green	Solution flow 1
LD9	Green	Solution flow 2

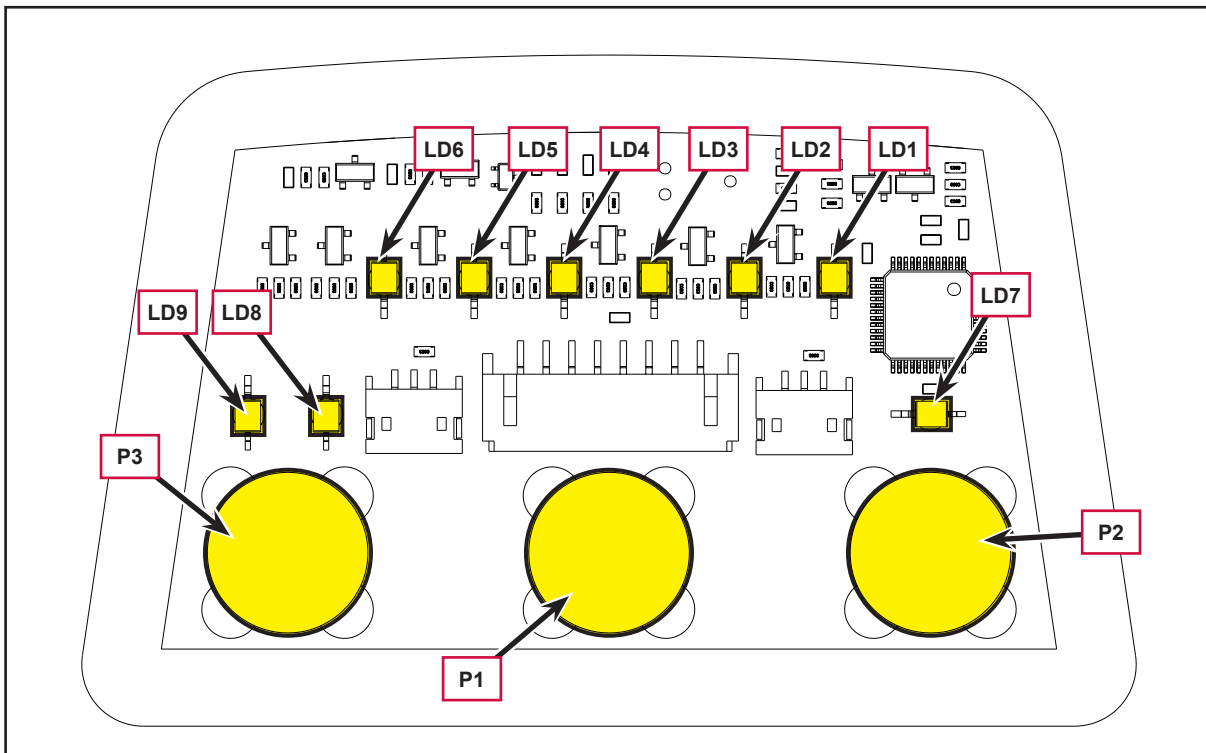

Figure 35 - (main control board - back view)

10 - Chassis System

Chassis (main parts)

Reference to Figure 1

- Plastic tank support chassis, solution system and recovery water system
- Metal handlebar support chassis and battery housing

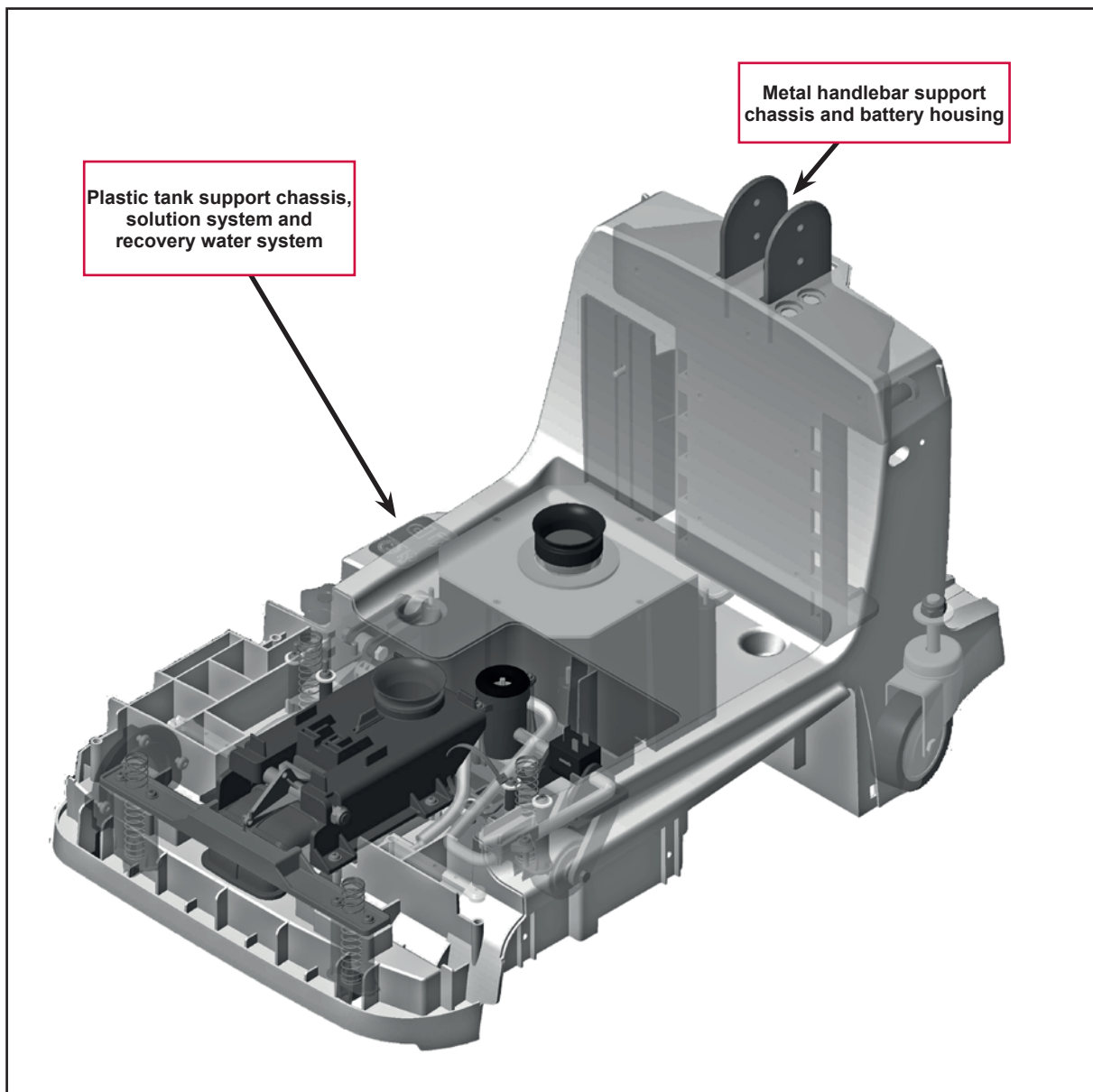

Figure 1

14 - Wheel System, Non Traction

Functional Description

The wheels assembly is composed by a pair of pivoting rear wheels and a pair of front wheels. The front axle is fitted with a pedal mechanism for moving and parking the machine with the brush and squeegee assembly lifted from the floor.

Component Locations

- Pivoting rear wheels
- Front wheels
- Machine lifting front axis
- Movement/parking - washing/drying pedal

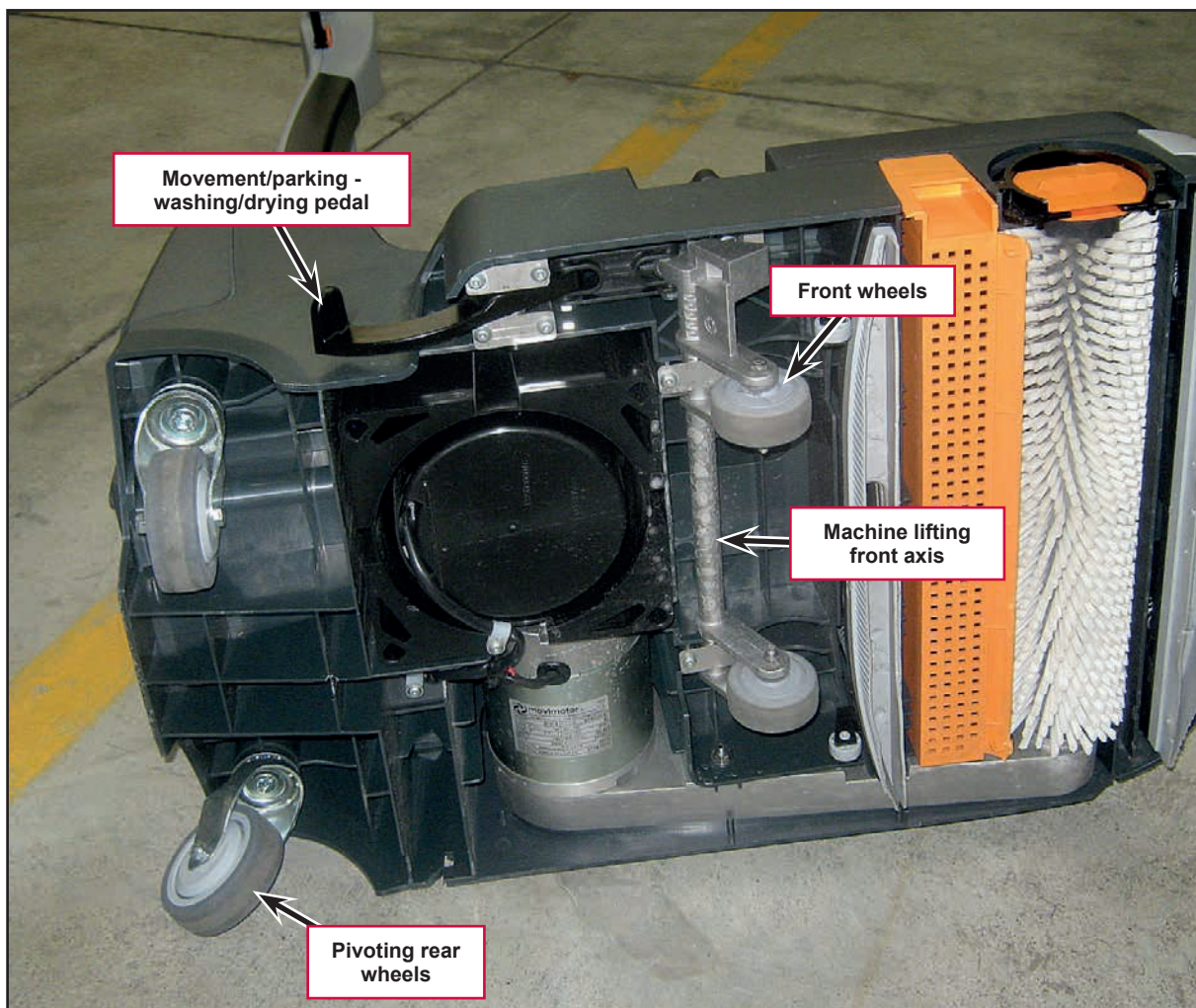

Figure 1

Specifications

Description / Model	Advance SC250, Clarke MA 30 Nilfisk SC250, Scrubtec 334
Rear rotating wheel diameter	3 in (75 mm)
Front wheel diameter	2 in (50 mm)
Maximum gradient when working	2%

24 - Electrical System

Functional Description

The machine electrical system is composed of the following components:

- **Lithium battery:** the battery pack contains the lithium cell protection system (Battery Management System) and provides power (36Vdc nominal voltage) to the machine system only after an activation system is provided by the machine start push-button located on the Main control board (EB2). Voltage from the battery can therefore only be directly measured at the battery connector during machine operation. The battery connector also contains the signal outputs necessary to display the battery charge level on the machine control panel. Any error codes from the battery management system (BMS) are displayed exclusively via the yellow and red LEDs on the battery, which can be activated by pressing the push-button next to the LEDs themselves.
- **Main machine controller (EB1):** it receives the controls from the Main control board (EB2) and provides power directly to all machine components (motors, pump, solution sensor). It also receives the battery charge level signals which are transmitted to the controller to be displayed.
- **Main control board (EB2):** this is fully responsible for the user interface, as it contains all control push-buttons and the indicator LEDs, and is connected to the 2 operator presence sensors on the handlebars. All information from and for the user is exchanged with the Main machine controller (EB1) via I2C protocol.

LED Operation on Main Control Board

DISPLAY DURING DISCHARGE (machine operation)						
Battery level (approximated $\pm 5\%$)	LD1	LD2	LD3	LD4	LD5	LD6
>90%	On	On	On	On	On	On
75% - 90%	On	On	On	On	On	
60% - 75%	On	On	On	On		
45% - 60%	On	On	On			
30% - 45%	On	On				
15% - 30%	On					
0% - 15%	Flash					

DISPLAY DURING CHARGE (charger output connected to CHARGE.1,2)						
Battery level (approximated $\pm 5\%$)	LD1	LD2	LD3	LD4	LD5	LD6
0% - 15%	Flash					
15% - 30%	On					
30% - 45%	Flash	On				
45% - 60%	Flash	Flash	On			
60% - 75%	Flash	Flash	Flash	On		
75% - 90%	Flash	Flash	Flash	Flash	On	
>90%	Flash	Flash	Flash	Flash	Flash	On
Charge completed						On

Wiring Diagram

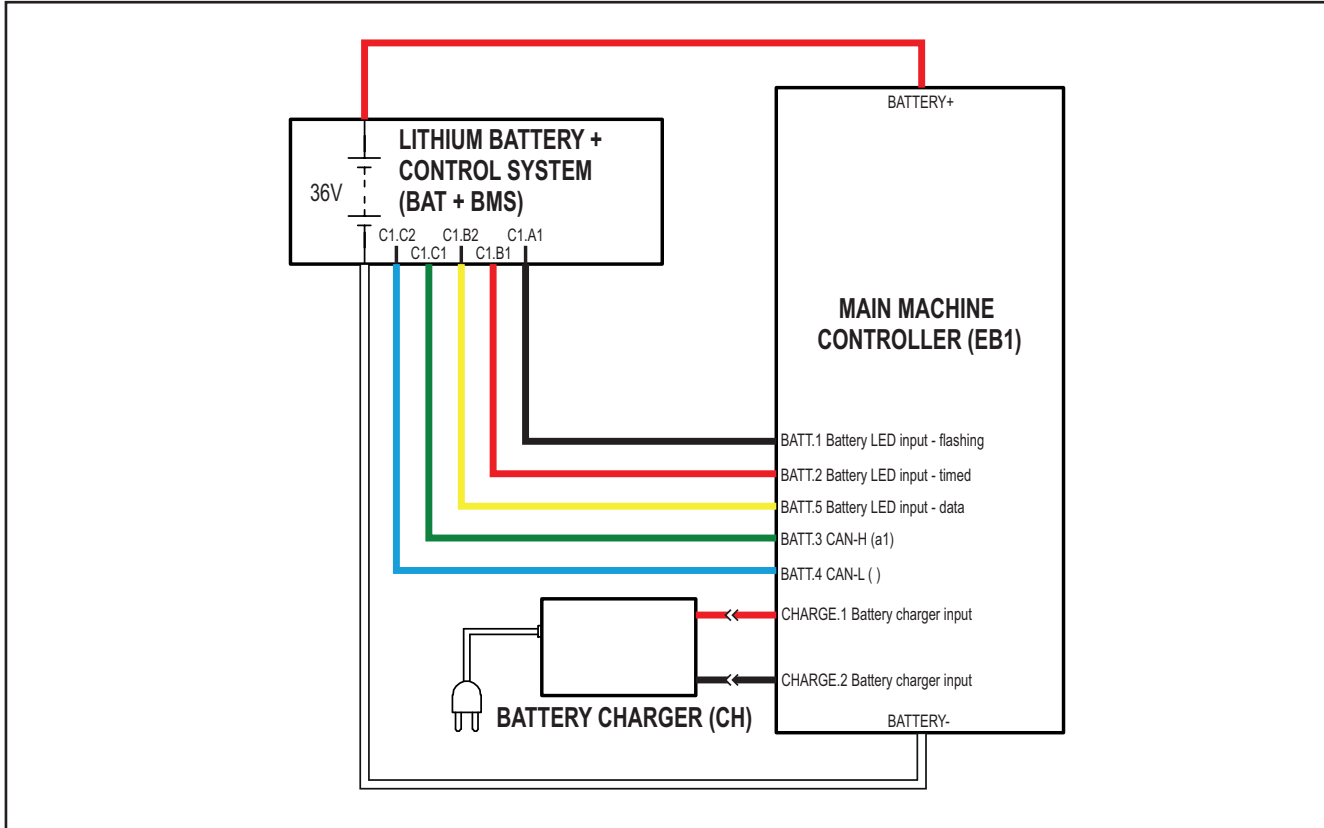

Figure 1

Component Locations

- Battery charger (CH)
- Battery charger connection socket
- Lithium battery (BAT)
- Battery connector (C1)

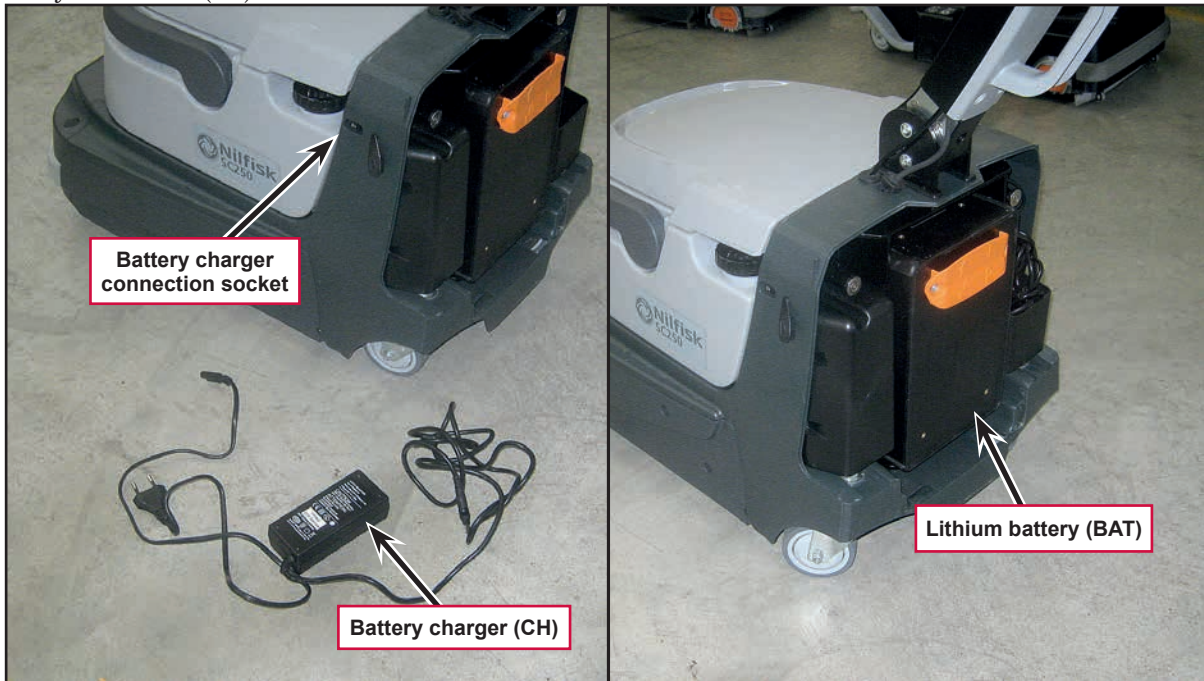

Figure 2

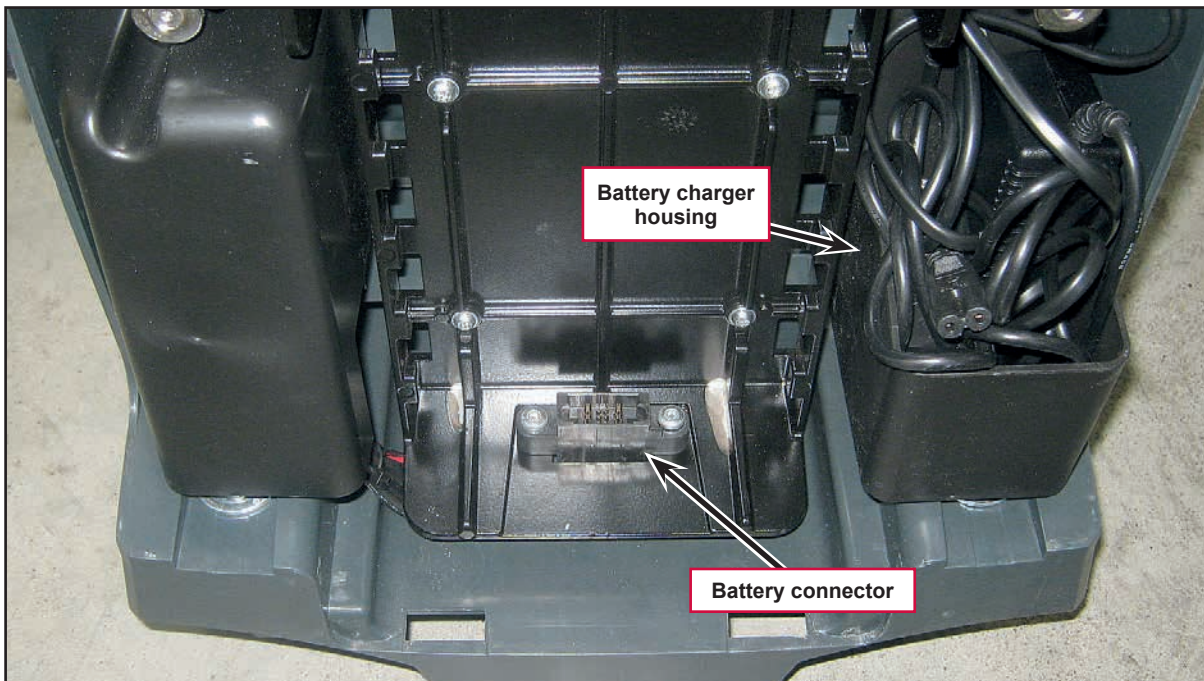

Figure 3

Maintenance and Adjustments

Battery Installation

1. Remove the rear cover on the battery compartment.
2. Grasp the battery handle, then push it downwards to seat it in place.

Battery Charging



Caution! *Charge the battery when only one LED of the battery symbol is light. When the battery is discharged, charge is as soon as possible, as that condition makes its life shorter. Check for battery charge at least once a week.*

1. Drive the machine to the appointed recharging area.
2. Ensure that the machine is off.
3. Connect the battery charger cable plug into the machine socket and the power supply cable plug into a mains socket (the mains voltage and frequency must be compatible with the battery charger values shown on the data plate).



Note: *When the battery charger is connected to the electrical mains, all machine functions are automatically cut off.*

4. During charging, one of the 6 LEDs of the battery icon will remain steadily lit to indicate the percentage of charging performed, while the other LEDs (to the left of the LED which is lit steadily) will flash sequentially.
5. When the 6th LED of the battery icon is lit steadily, battery charging is complete.
6. Disconnect the battery charger from the mains and from the machine socket.
7. Open the battery compartment cover and place the battery charger in its tray.
8. Close the rear cover on the battery compartment.

Battery Charge Level

1. The battery charge level can be viewed on the battery icon LEDs (5).
2. The battery charge percentage depends on the number of LEDs lit, as shown in the figure 11.
3. When the first left LED flashes (15%), the machine will only run for a few more minutes (this will depend on the characteristics of the work to perform).

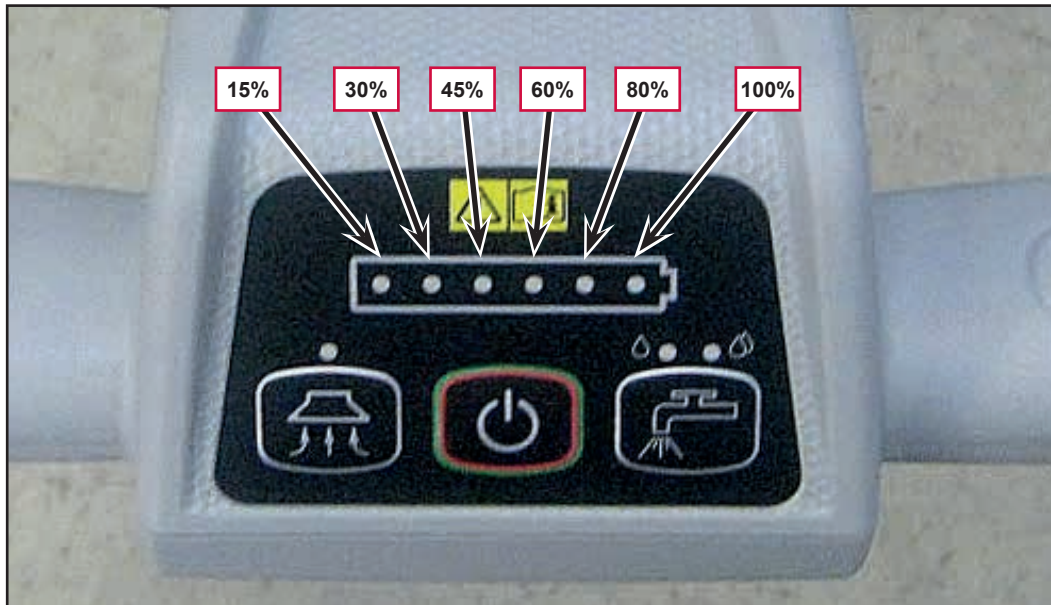

Figure 4

Charging the Battery when Removed from the Machine

1. Remove the battery from the machine.
2. Place the battery in the appointed recharging area.
3. Connect the battery charger cable plug (B) into the battery socket (A) and the power supply cable plug into a mains socket (the mains voltage and frequency must be compatible with the battery charger values shown on the data plate).
4. During charging, one of the 6 green LEDs on the battery (C) will remain steadily on to indicate the percentage of charging performed, while the other LEDs (to the left of the LED which is on steadily) will flash sequentially.
5. When the 6th LED is lit steadily, battery charging is complete.
6. Disconnect the battery charger from the mains and from the battery.



Note: When the battery is not connected to the battery charger, you can see the battery charge level by pressing the button (D) briefly. The number of green LEDs (C) turned on is proportional to the battery charge level percentage.

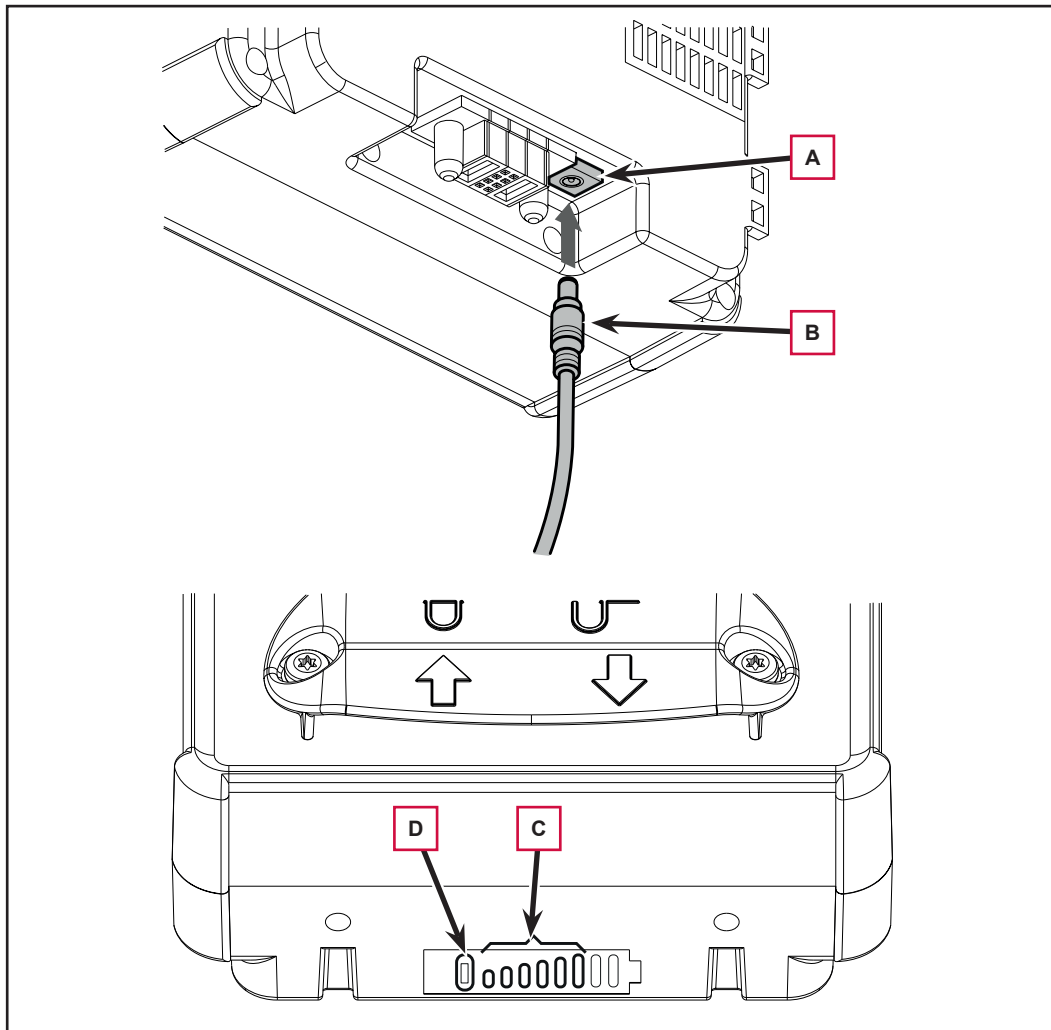

Figure 5

Display on Battery

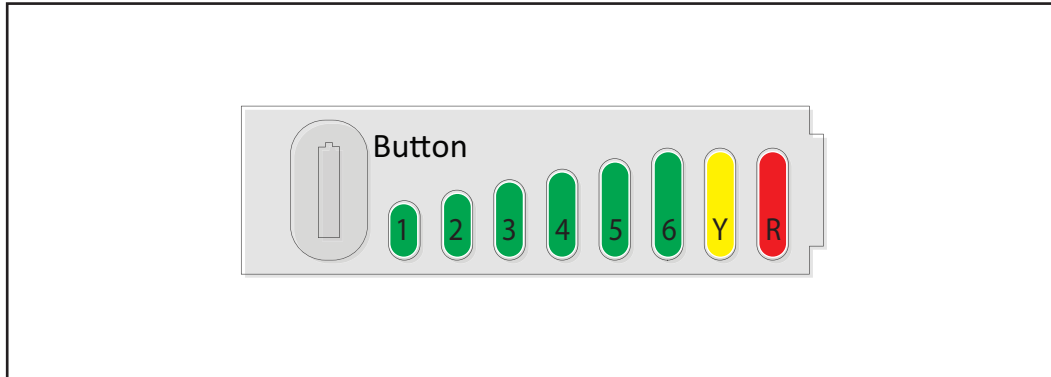

Figure 6

The battery pack contains the above “Display”, which consists of a Button to activate the display if not under charge or discharge, 6 green LED’s to indicate the remaining capacity, a Yellow LED to give warnings and a Red LED to show errors. The available battery capacity is indicated by the first 6 LED’s as follows:

1st Green LED (Flashing)	< 15 %
1st Green LED (Solid)	≥ 15 %
2nd Green LED	≥ 30 %
3rd Green LED	≥ 45 %
4nd Green LED	≥ 60 %
5nd Green LED	≥ 75 %
6nd Green LED	≥ 90 %

The 6 green LED’s are “rolling” during charge and static during discharge.

The **Yellow LED** and **Red LED** gives the following information during charging:

- **Yellow LED (Solid): High or low temperature**

The battery pack temperature is high or low and the charging time is prolonged, depending on the charger type. Regular charging will start automatically when the battery temperature is within the recommended temperature range.

- **Yellow LED (Flashing): No charging**

The charger has been disconnected before the battery pack was fully charged.

- **Red LED (Flashing): No charging**

The battery cell temperature is lower than 0°C (32°F) or higher than +50°C (+122°F). Charging will start automatically when the battery temperature is within a chargeable temperature.

The **Yellow LED** and **Red LED** gives the following information during discharging:

- **Yellow LED (Flashing): Low capacity**

A flashing Yellow LED together with a flashing Green LED indicates that the capacity is low and that the battery pack needs recharging.

A flashing Yellow LED without a flashing Green LED indicates that the battery pack is empty and needs recharging.

- **Red LED (Fast flashing): No discharging**

The battery temperature is lower than -20°C (-4°F) or higher than +55°C (+131°F). (Wait until the battery temperature is within operative temperature) The Red LED will also give a fast flashing if the battery pack is overloaded. (Remove the overload)

Red LED (3 Fast flashes followed by pause)

The battery pack is defect and beyond repair and should not be used anymore.

All LED’s will go off approx. 10 seconds after fully charge has been detected in order to reduce the energy consumption. All the LED’s will also go off approx. 10 seconds after a “Button” activation or after deactivation of the application.

For more detail see table on the Battery LED behavior paragraph.

Troubleshooting

Trouble	Possible Causes	Remedy
The machine is not working	Battery (BAT) flat or connections faulty	Charge the battery or clean the connections
	Battery (BAT) broken	Check the battery no-load voltage
The battery will not charge	The battery charger (CH) is broken	Replace



Note: Damage to the battery charger or its connections can prevent the machine from operating properly.

Battery LED behavior

Scenario	Yellow LED	Red LED	Description	Consequence	Indication on the machine display battery LEDs
Charging in High temperature	ON	OFF	Indicates slow charge above +40°C	None, only slower charging than usual	No indication
Charging in Low temperature	ON	OFF	Indicates slow charge below +10°C	None, only slower charging than usual	No indication
Charge temperature too high	OFF	200mS On/Off	No charging above +50°C (Relevant Green LED On)	Stop charging	1 solid Green LED, indicating actual capacity.
Charge temperature too low	OFF	200mS On/Off	No charging below 0°C (Relevant Green LED On)	Stop charging	1 solid Green LED, indicating actual capacity.
Charge current too low	400mS On/Off	OFF	Indicates that charger is removed before fully charged	None	1 solid Green LED, indicating actual capacity. (10 sec.)
Charge current too high	400mS On/Off	400mS Off/On	Indicates that the charge current is too high	Stop charging	1 solid Green LED, indicating actual capacity.
Charge current overload	ON	200mS On/Off	Indicates a charge overcurrent (Inrush)	Stop charging	1 solid Green LED, indicating actual capacity. (10 sec.)
Discharge temperature too high	OFF	200mS On/Off	Indicates a discharge temperature above 55°C	Stop machine functions	1 solid Green LED, indicating actual capacity. (10 sec.)
Discharge temperature too low	OFF	200mS On/Off	Indicates a discharge temperature below -20°C	Stop machine functions	1 solid Green LED, indicating actual capacity. (10 sec.)
Discharge current too high	OFF	200mS On/Off	Indicates a discharge current above 25 Amp (5 seconds)	Stop machine functions	1 solid Green LED, indicating actual capacity. (10 sec.)
Discharge overload	OFF	200mS On/Off	Indicates a discharge current above 30 Amp (400mS)	Stop machine functions	1 solid Green LED, indicating actual capacity. (10 sec.)
Battery capacity low warning	400mS On/Off	OFF	Indicates capacity below 10% or cell below 3.2-V	None	1 flashing Green LED
Battery empty	400mS On/Off	OFF	Indicates empty battery pack	No machine functions	No indication
Mosfet temperature too high	400mS On/Off	400mS On/Off	Indicates that the Mosfets is too hot (>90%)	Stop machine functions	1 solid Green LED, indicating actual capacity. (10 sec.)
Battery pack defect	OFF	Special	Indicates that the battery pack should be replaced	Stop machine functions	1 solid Green LED, indicating actual capacity. (10 sec.)

Specifications

Description / Model	Advance SC250, Clarke MA 30 Nilfisk SC250, Scrubtec 334
IP protection class	X4
Protection class (electric)	III
Electrical system voltage	36Vdc
Standard battery	Lithium Ion - 36Vdc 8Ah
Battery charger output	42Vdc 1÷2A
Operating time (EN 60335-2-72)	40 min

Wiring Diagram

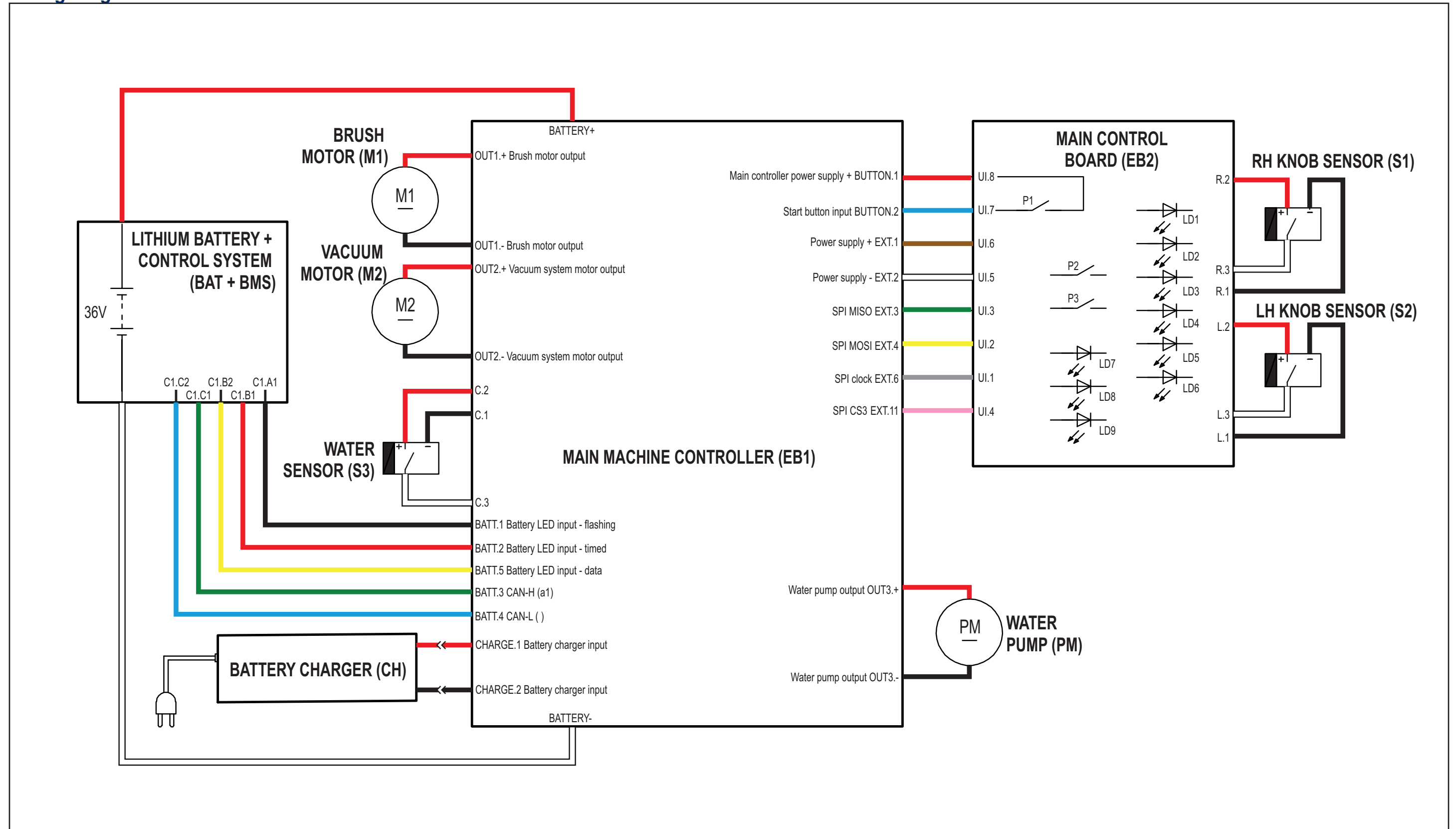

Figure 6

30 - Solution System

Functional Description

The solution system supplies detergent to the brush when cleaning the floor. The solution tank is also part of the machine recovery tank. The solution flows from the tank to the valve before reaching the filter and the water pump (PM), and then to the solution dispensers in the brush compartment area.

The system also includes a water sensor (S3) which warns the operator when the solution tank is empty via the two washing push-button LEDs.

Solution flow levels 1 and 2 regulate the flow of solution to meet requirements.

If the water sensor (S3) does not detect water inside the hose within 10 seconds of the pump starting up, the pump is stopped and the fault is indicated by the 2 solution flow LEDs (LD8, LD9) flashing alternately.

To re-activate the pump, just take both hands off the handlebars to deactivate the operator presence sensors (S1, S2), then reactivate them.

The pump operates only with the following inputs/conditions:

- Brush function on
- At least one of the two handlebar sensors activated
- Sufficient battery charge level: at least one LED on flashing.

Water Flow				
Flow rate set	Square pulse Ton (+24V)	Square pulse Toff	LD8	LD9
1 (default)	18ms	36ms	On	Off
2	10ms	18ms	On	On
0	0ms	-	Off	Off

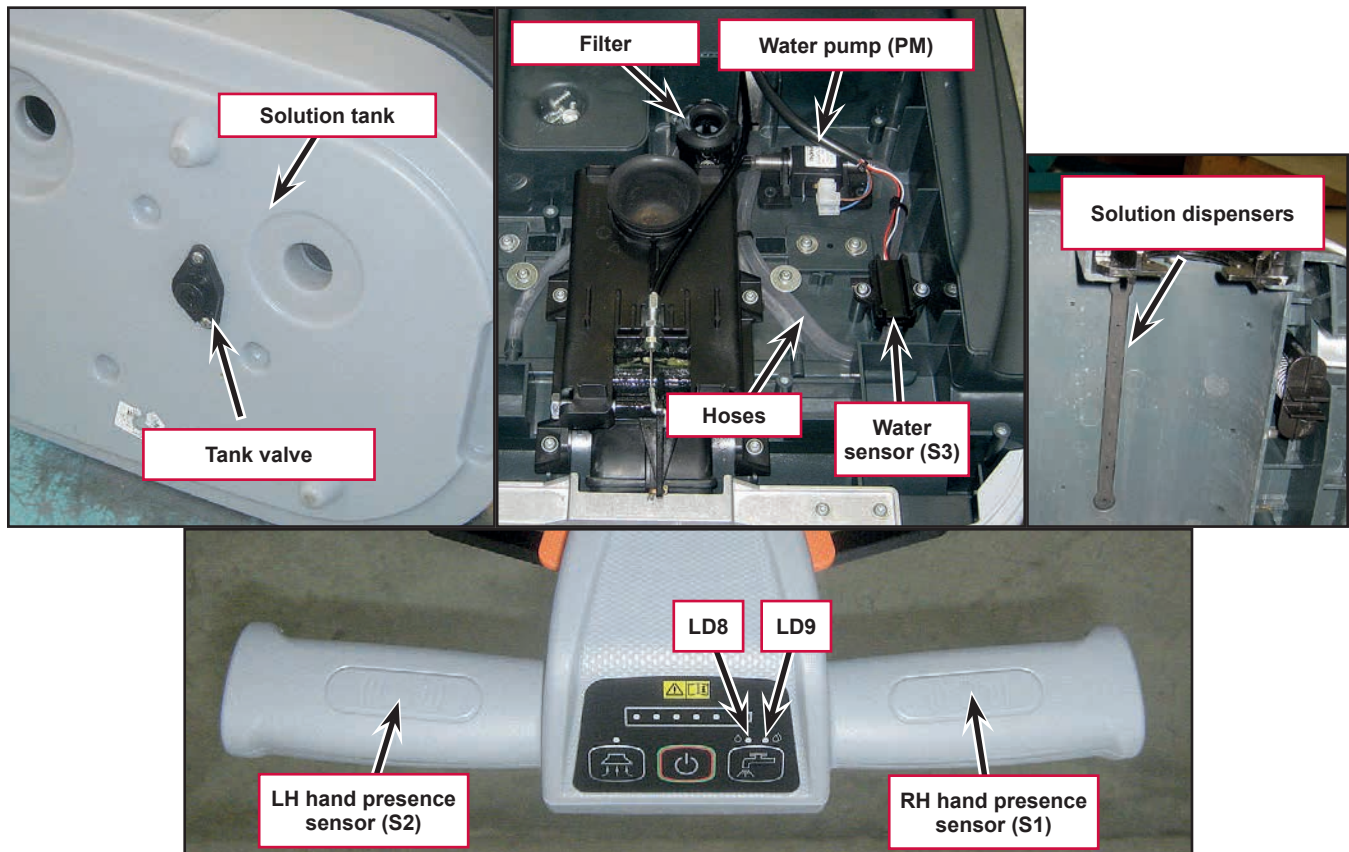

Wiring Diagram

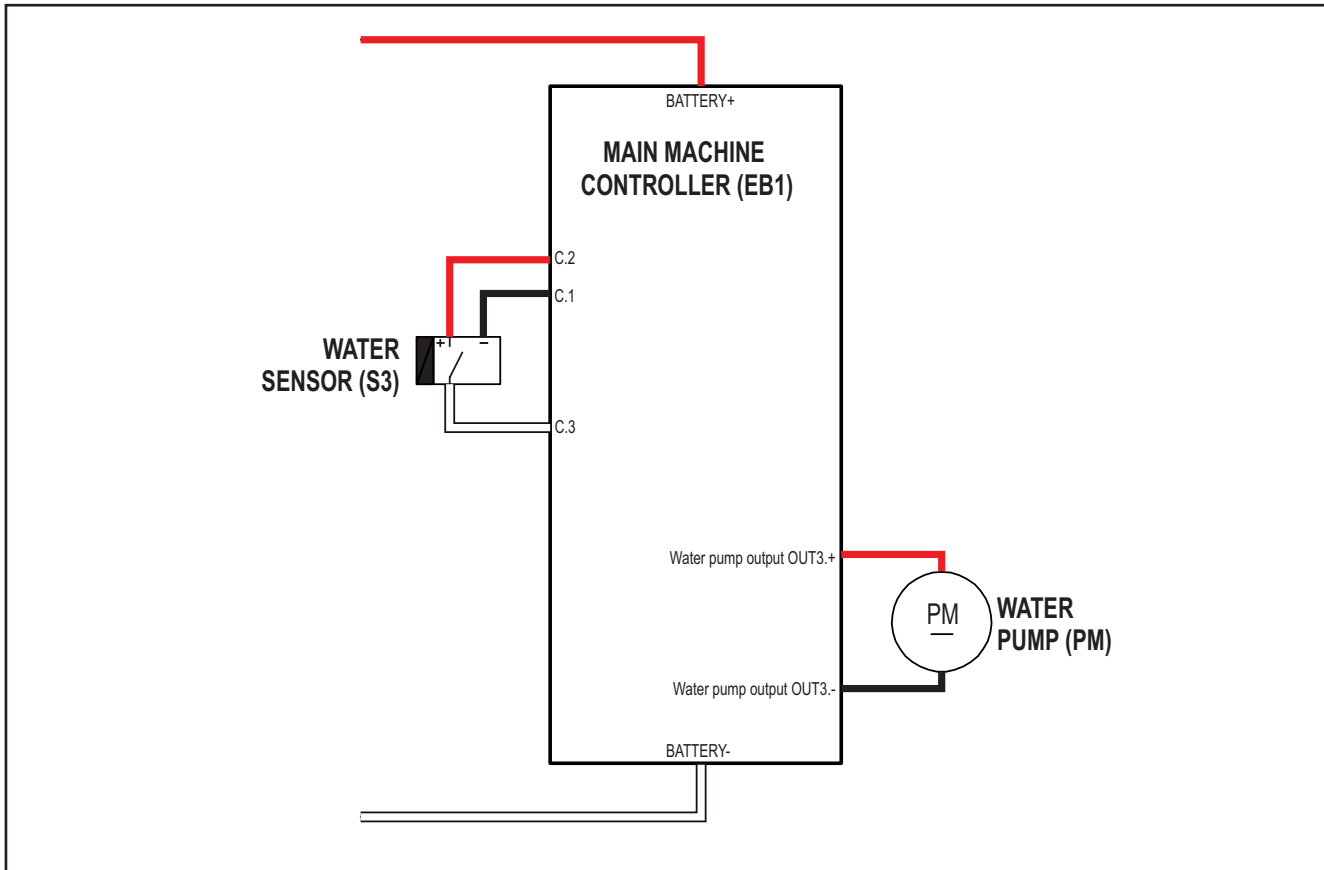

Figure 1

Component Locations

- Solution tank assembly
- Tank filler cap
- Tank valve
- Solution filter
- Water Pump (PM)
- Hoses
- Water sensor (S3)
- Solution dispenser to brush

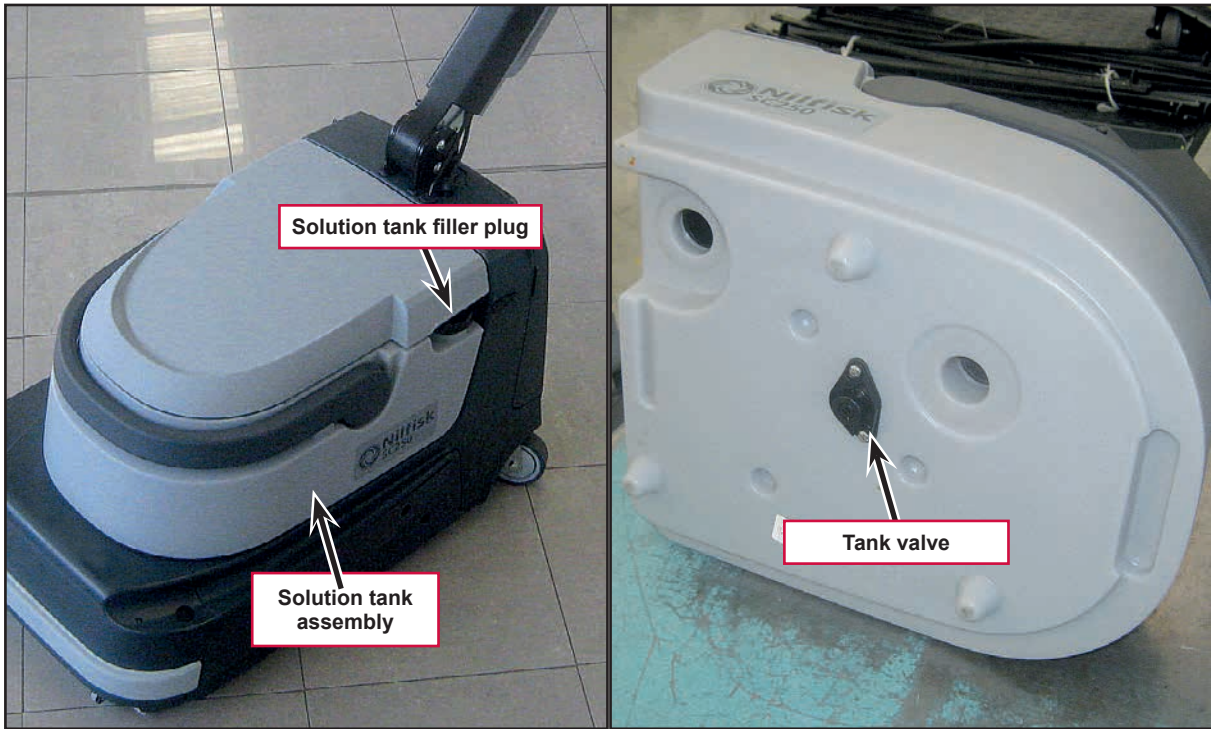

Figure 2

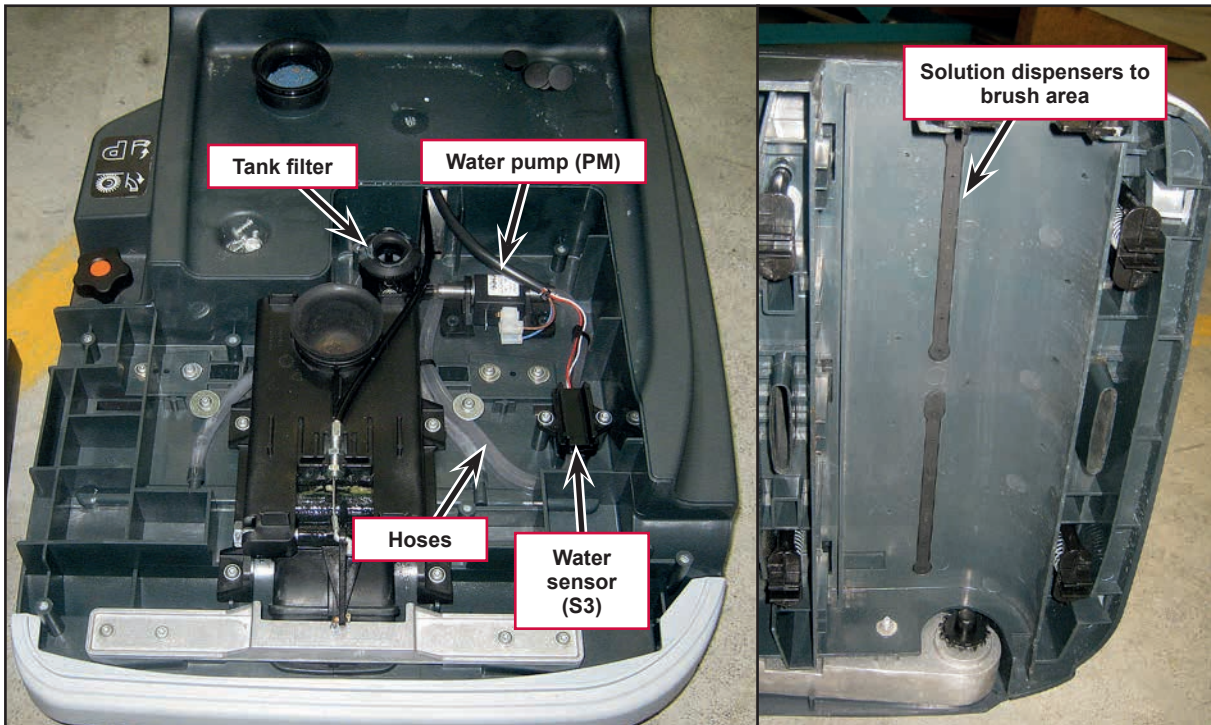

Figure 3

Maintenance and Adjustments

Cleaning the Solution Tank and Filter

1. Ensure that the machine is off.
2. Remove the tanks container from the machine body using the handle.
3. Lift the tank cover and remove the solution cap.
4. Rinse the tank out with water
5. Remove the rubber gasket (A), then remove the filter strainer (B).
6. Clean them carefully and reinstall (C).



Figure 4

Solution Dispenser Cleaning

1. Ensure that the machine is off.
2. Remove the tanks container from the machine body using the handle.
3. Lift the machine body to access the lower part of the cleaning deck.
4. Remove the cylindrical brush.
5. Disassemble the solution dispensers (A) and clean them with water and detergent, then rinse and reassemble in the corresponding housings.

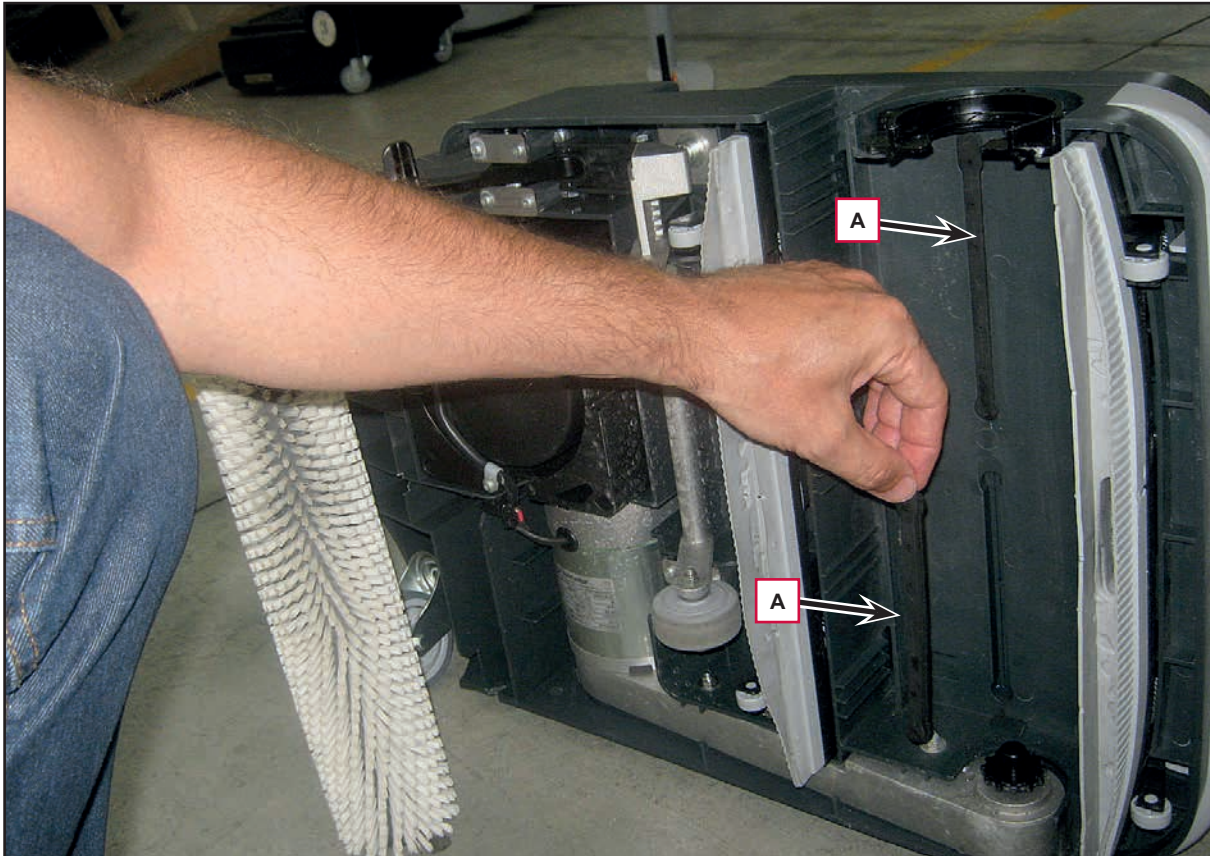

Figure 5

Troubleshooting

Trouble	Possible Causes	Remedy
The solution push-button LEDs flash	Solution tank empty	Fill the tank
Small amount of solution or no solution reaches the brush	Solution dispensers clogged.	Clean the solution dispensers.
	Solution filter clogged/dirty	Clean the filter
	Water pump (PM) broken or electrical connection interrupted	Replace the pump/repair the electrical connection
	Presence of debris in solution tank blocking the outlet valve	Clean the tank and the valve
	Main machine controller (EB1) faulty	Replace
	Main control board (EB2) faulty	Replace
The solution reaches the brush also when the machine is off	Dirt or scale in water pump (PM), or else it is broken	Replace

Water Pump Voltage and Cleaning Check

Water Pump Voltage Check

1. Remove the tanks assembly from the machine.
2. Open the rear cover.
3. Unscrew the screw (A) and remove the function main machine controller protection cover (B).

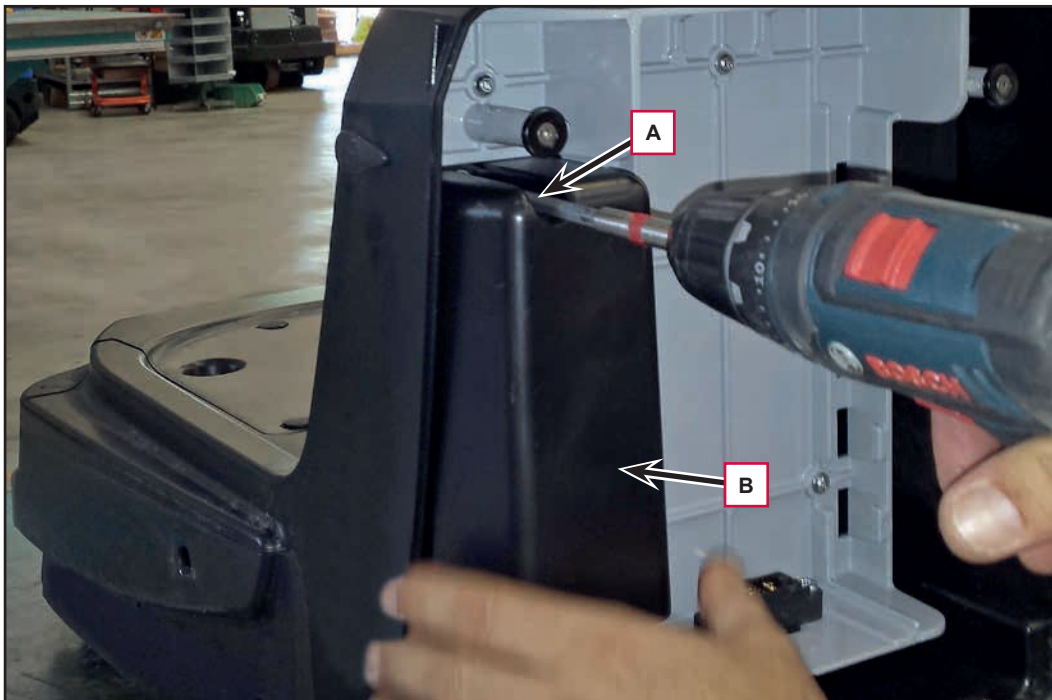

Figure 6

Water Pump Voltage and Cleaning Check (continues)

4. On the main machine controller , identify the two output water pump faston connections (C).
5. With a digital multimeter (D) set to AC input (E), verify that on the output water pump (C) is current an alternating voltage of $\sim 14 \div 16$ V with activated water pump.
6. If the water pump output is without voltage, check in the order:
 - a. Water pump wiring.
 - b. Water pump efficiency (Clean/unlock or replace).
 - c. Main machine controller efficiency.

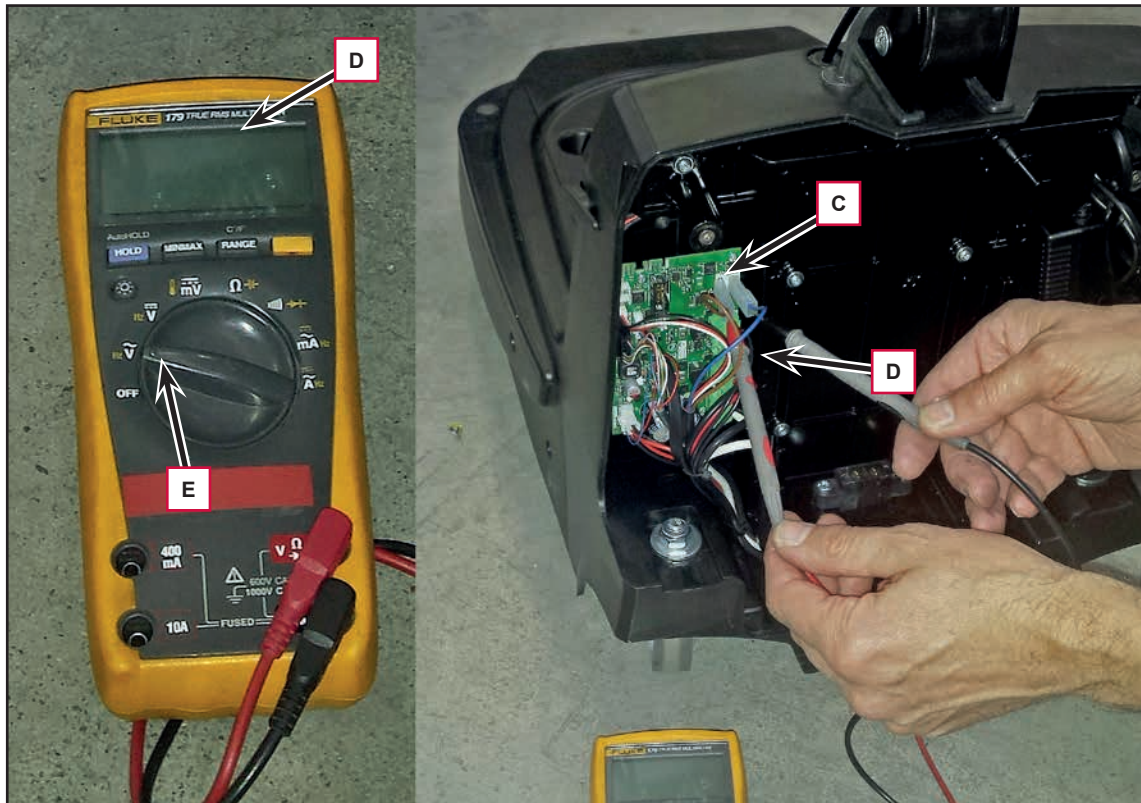

Figure 7

Water Pump Voltage and Cleaning Check (continues)

Water Pump Cleaning/Unlocking

7. Blow in the Water pump duct (F) with the compressed air at 1 bar max. (for the Water pump removal see the procedure in Water pump removal/installation paragraph),



Caution! Blow with compressed air on the arrow direction as shown on the pump label.

8. Eventually instead disassembling the Water pump, blow the inlet on the solution filter compartment (G) (use cloth to narrow the air flow).



Figure 8

Removal and Installation

Solution Tank Valve

1. Remove the tank assembly from the machine.
2. Working at the workbench, rotate the tank assembly and
3. Remove the 2 screws (A), remove the valve (B) and retain the gasket (C) for reuse.

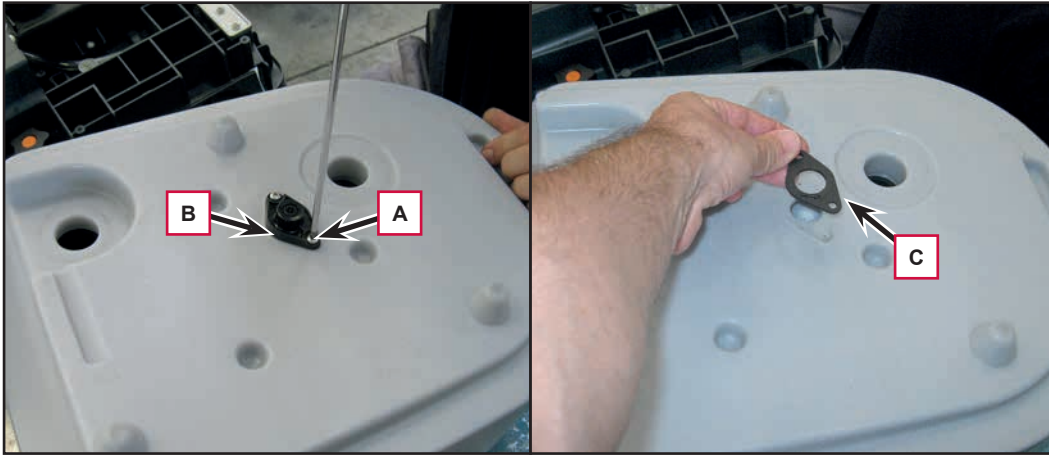

Figure 6

Water Pump

Removal

1. Remove the tank assembly from the machine.
2. Open the rear cover and remove the battery.
3. Remove the 7 caps (A) and remove the 7 screws (B), then remove the upper cover from the machine body (C).

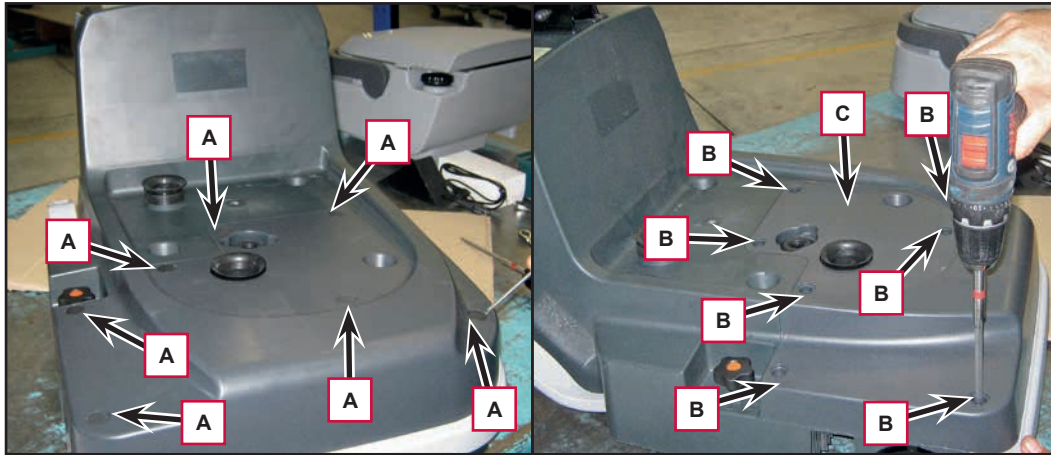

Figure 7

4. Disconnect the connection (D) and remove the Water pump (E), retaining the brackets and hoses for reuse.

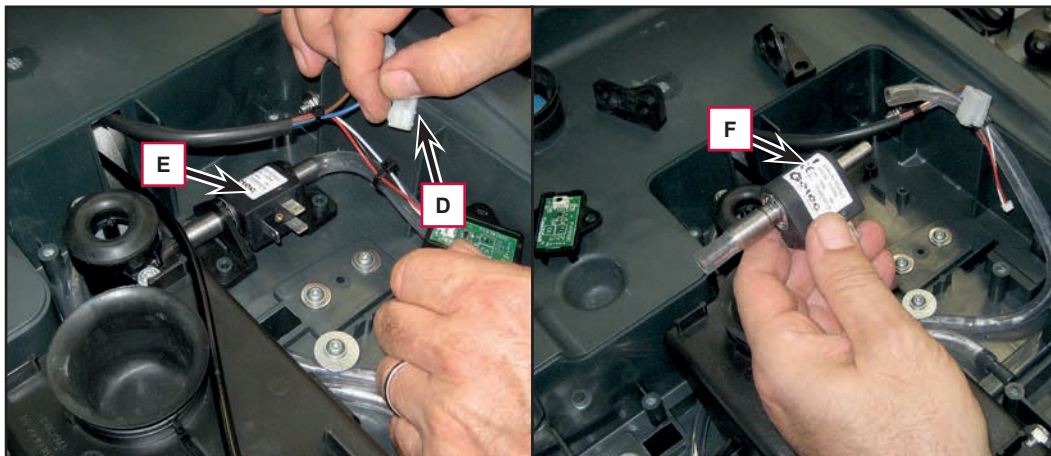

Figure 8

Installation

5. Install the components by performing the removal procedure in reverse, ensuring you respect the flow direction arrow (F) on the Water pump.

Water Sensor

Removal

1. Remove the tank assembly from the machine.
2. Open the rear cover and remove the battery.
3. Remove upper cover from the machine body (A).



Figure 9

4. Remove the 2 screws (A) and lift the cover (B) off the sensor bracket.
5. Disconnect the connection (C) and remove the water sensor (D) from the bracket.

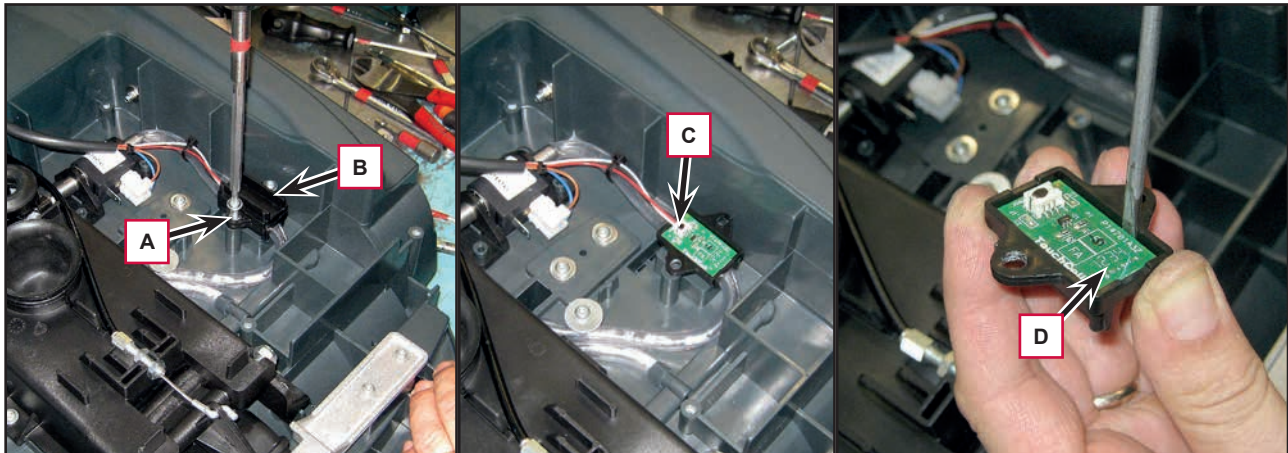

Figure 10

Installation

6. Assemble the components in the reverse order of disassembly.

Specifications

Description / Model		Advance SC250 / Clarke MA 30 / Nilfisk SC250, Scrubtec 334
Solution tank capacity		1.6 US gal (6 liters)
Min/max solution flow		0.04 / 0.08 US gal/min (0.15 / 0.3 L/min)
Water pump technical data	IP rating	IP54
	Maximum back pressure	0.8 bar
	Solution flow rate	21 L/h
	Input power	18W
	Insulation class	F
	Power consumption	< 900mA

34 - Scrub System

Functional Description

The scrub system is enabled when the machine is turned on.

The cylindrical brush rotates in the direction of travel machine.

The rotating scrub system cleans/washes the surface of the floor. The area where brushes suitable for cleaning the particular type of floor are installed is the main part of the scrub system.

When the brush is coupled to the drive hub, it is connected to the motor via a toothed belt inside the left-hand casing.

Brush rotation occurs only when the brush motor (M1) is driven by the main machine controller after the machine is started up.

The scrub system uses the solution to wash the floor. The knob on the right-hand side of the machine body regulates the pressure of the brush on the ground. Turning it clockwise increases pressure (+), counter-clockwise decreases it (-).

A perforated tank, positioned behind the brush, collects small and medium sized debris picked up by the brush.

In the event of brush motor overload, a safety system stops the brushes after about 25 seconds of continuous overload.

The overload is detected by the Main machine controller (EB1) by monitoring the current flow to the brush motor. Operation of the brush motor overload protection system is indicated by all 6 battery LEDs flashing simultaneously on the main control board.

To start work again after a brush stop due to overload, turn the machine off and then on again.

To work properly, the brush motor (M1) needs the following:

- Brush function on
- At least one of the two handlebar sensors activated
- Sufficient battery charge level: at least one LED on flashing.

The brush motor (M1) is stopped if it turn for 60 seconds (even if not continuously) during the water sensor (S3) is not sensing the solution presence.

To restore the brush motor turn or to reset the 60 seconds counter, switch off and on the machine.

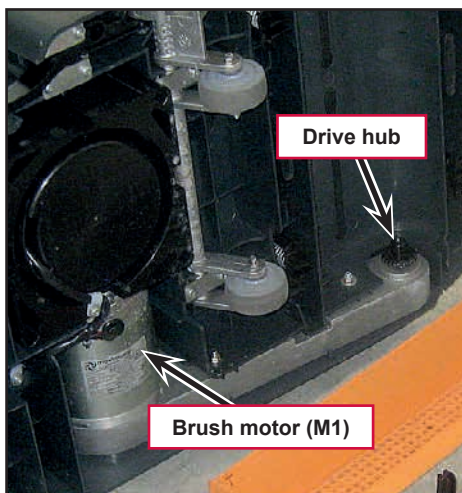
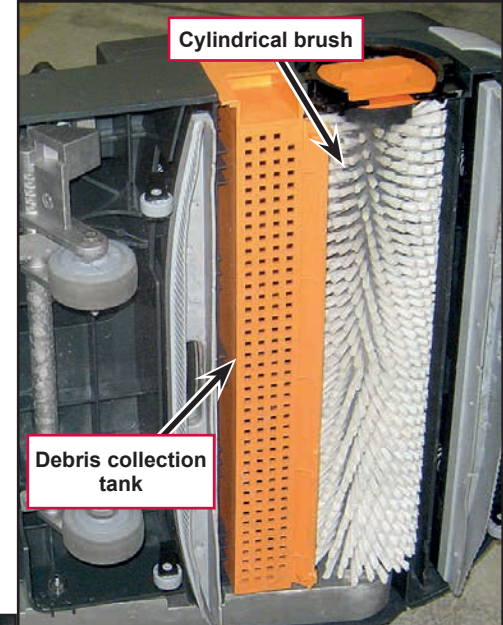
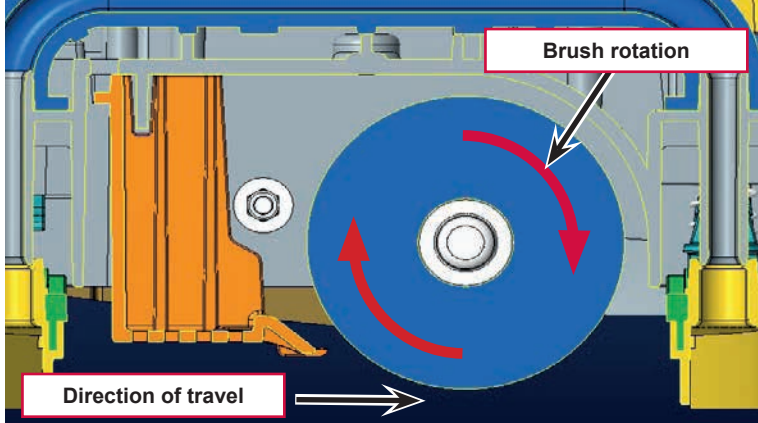

Wiring Diagram

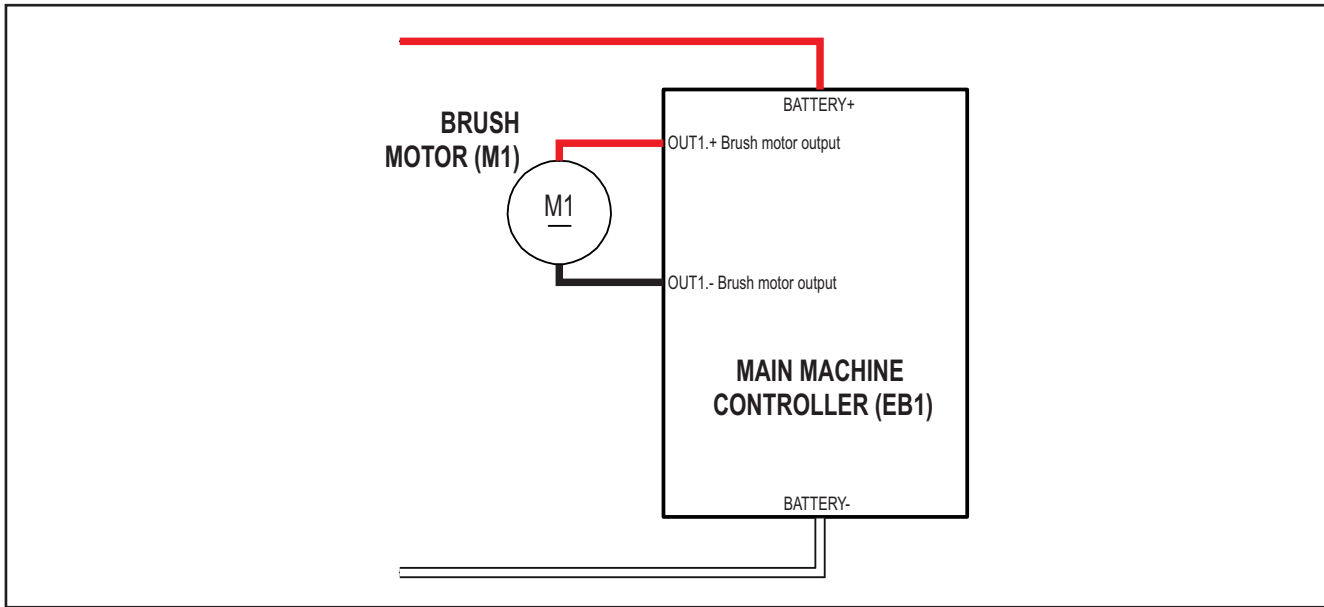

Figure 1

Component Locations

- Brush motor (M1)
- Cylindrical brush
- Drive hub
- Driving belt
- Floor brush pressure adjustment knob
- Debris collection tank

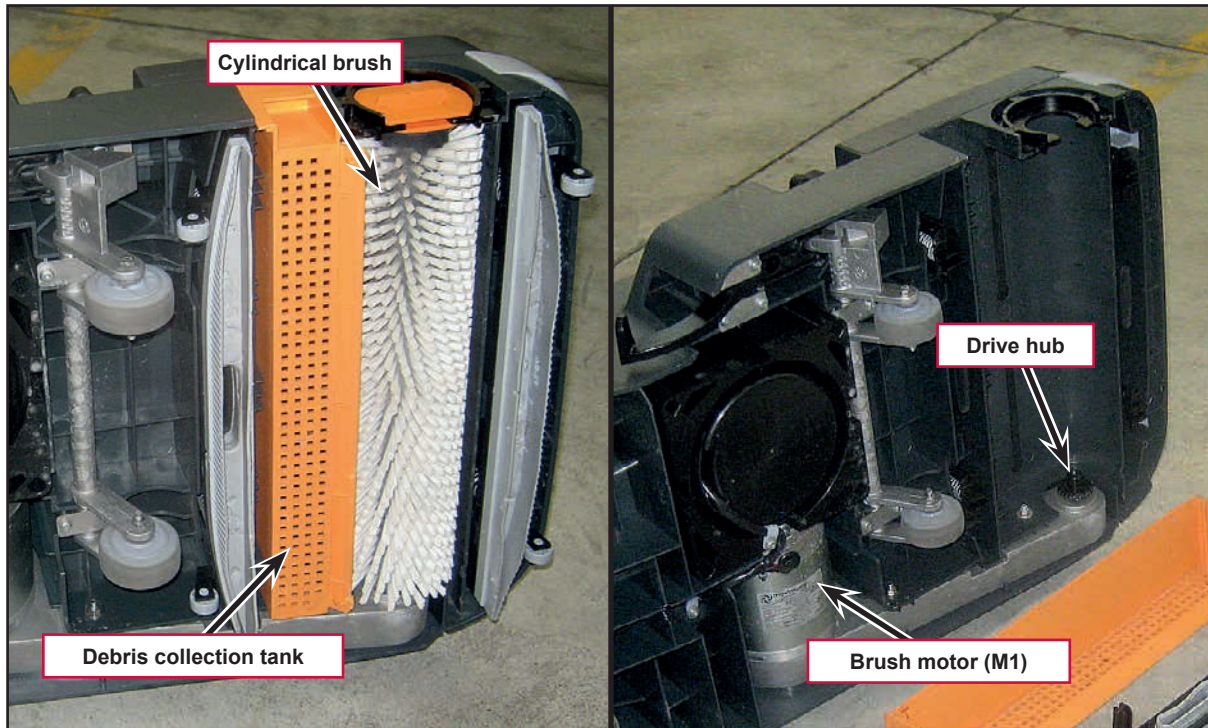

Figure 2

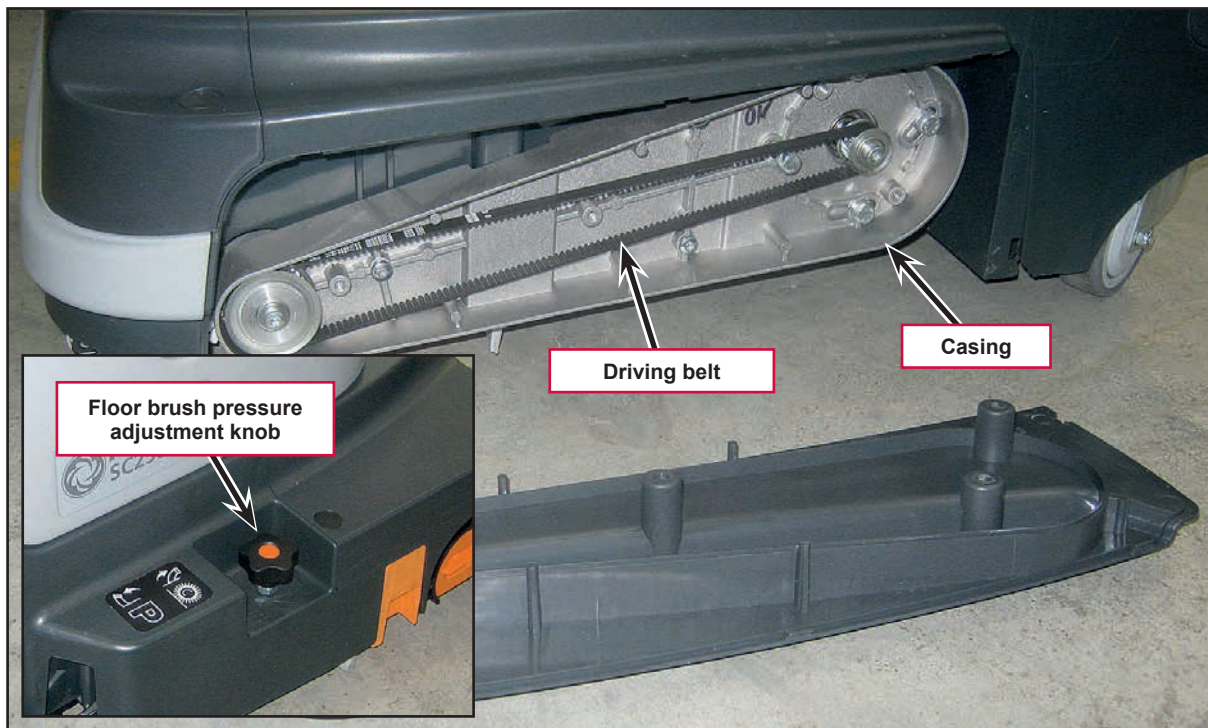

Figure 3

Maintenance and Adjustments

Brush and Brush Compartment Cleaning

1. Ensure that the machine is off.
2. Remove the tanks container from the machine body using the handle.
3. Lift the machine body to access the lower part of the cleaning deck.
4. Turn the lever counter-clockwise (A) and remove the brush.
5. Clean and wash the cylindrical brush with water and detergent.
6. Check the brush bristles for integrity and wear; if necessary, replace the brush.
7. Carefully clean the brush compartment (B).
8. Remove the debris collection tank (C), clean it and rinse it with clean water, then put it back in its seat.
9. Reinstall the cylindrical brush on the drive hub (D) and engage it by turning the lever (E) clockwise.

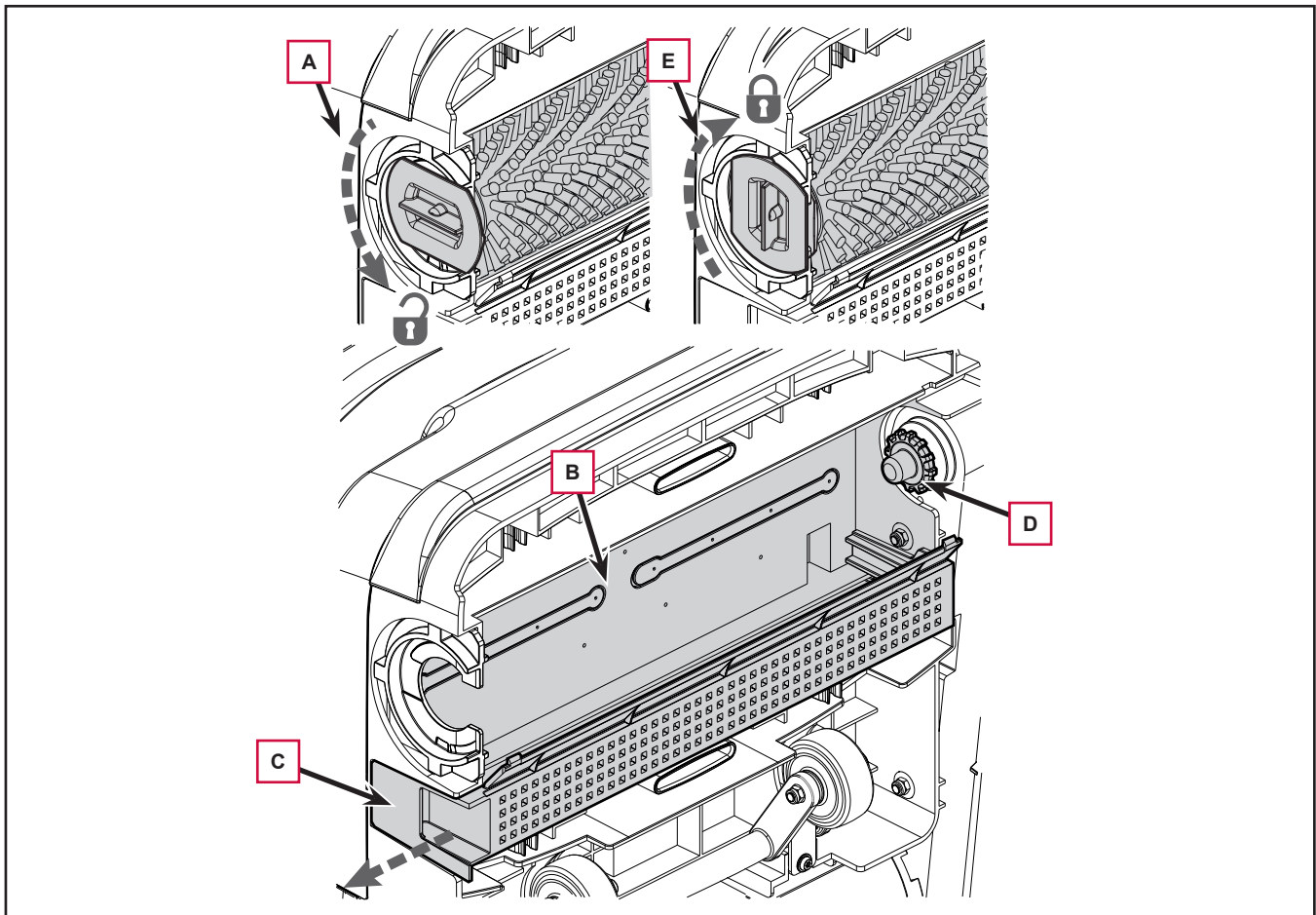

Figure 4

Troubleshooting

Trouble	Possible Causes	Remedy
The brush does not clean properly	The brush is excessively worn	Replace
The battery LEDs flash while working	Brush motor overload	Reduce the brush pressure on the floor
	There are foreign materials (tangled threads, etc.) preventing the brush from rotating.	Clean the brush hub
The brush does not turn	Presence of bulky debris or string around the brush or between the brush and attachment flange	Remove the brush and clean it
While running, the machine is noisy and it vibrates	Deformed brush bristles	Wash the brush with hot water to restore the bristles
		Do not leave the machine parked without the transport/parking wheels
The brush does not turn. (The solution push-button LEDs flash)	The solution flow is missing for more than 1 minute	Fill the solution tank, turn the machine off and then on

Brush Motor Amperage Check



Warning! This procedure must be performed by qualified personnel only.

1. Open the rear cover on the battery compartment.
2. Remove the screw (A) and remove the controller protective cover (B).

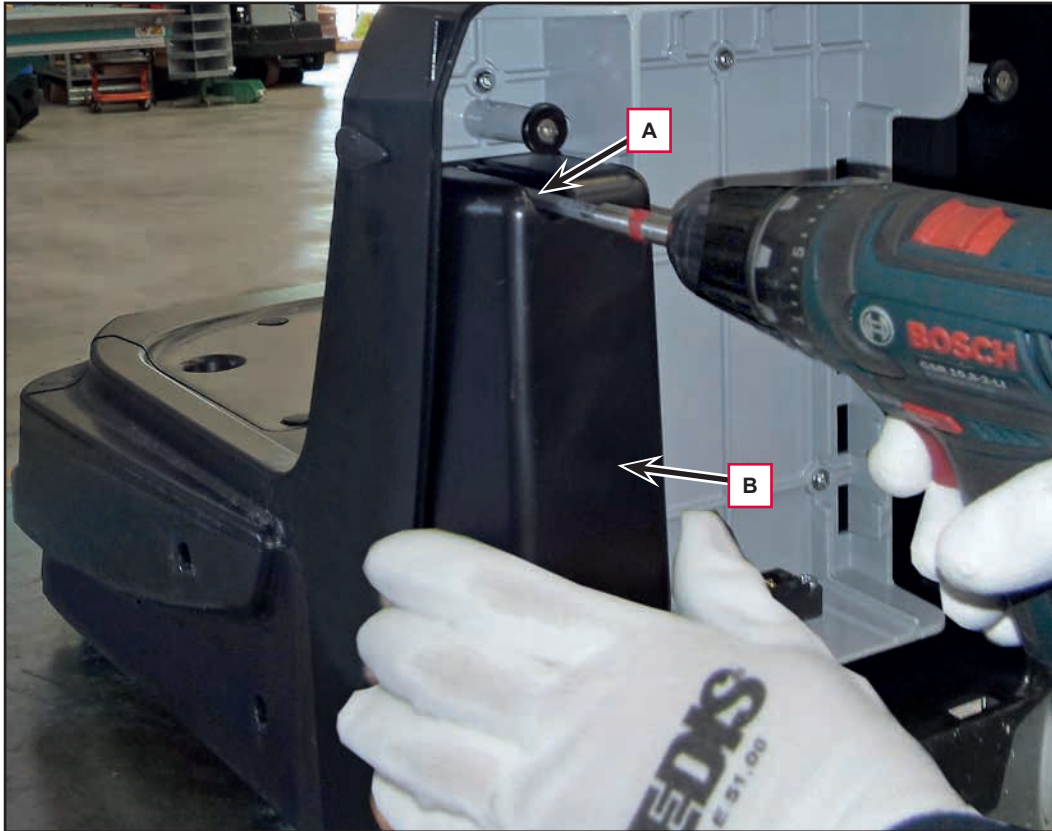

Figure 5

Brush Motor Amperage Test (continues)

3. Apply the amp clamp (C) to the electrical cable (D) of the brush motor.
4. Switch on the machine and operate it with one hand on the handlebar.
5. Check that the brush motor current draw is no more than 1 A at 36 V.
6. If the current draw is higher, check the belt tension or remove the brush motor (see the procedure in the Vacuum System Motor Disassembly/Assembly paragraph), and check the condition of all its components to detect and correct the reason for the abnormal current draw:

If the above-mentioned procedures do not produce the correct readings for the brush motor current draw, the motor must be replaced.

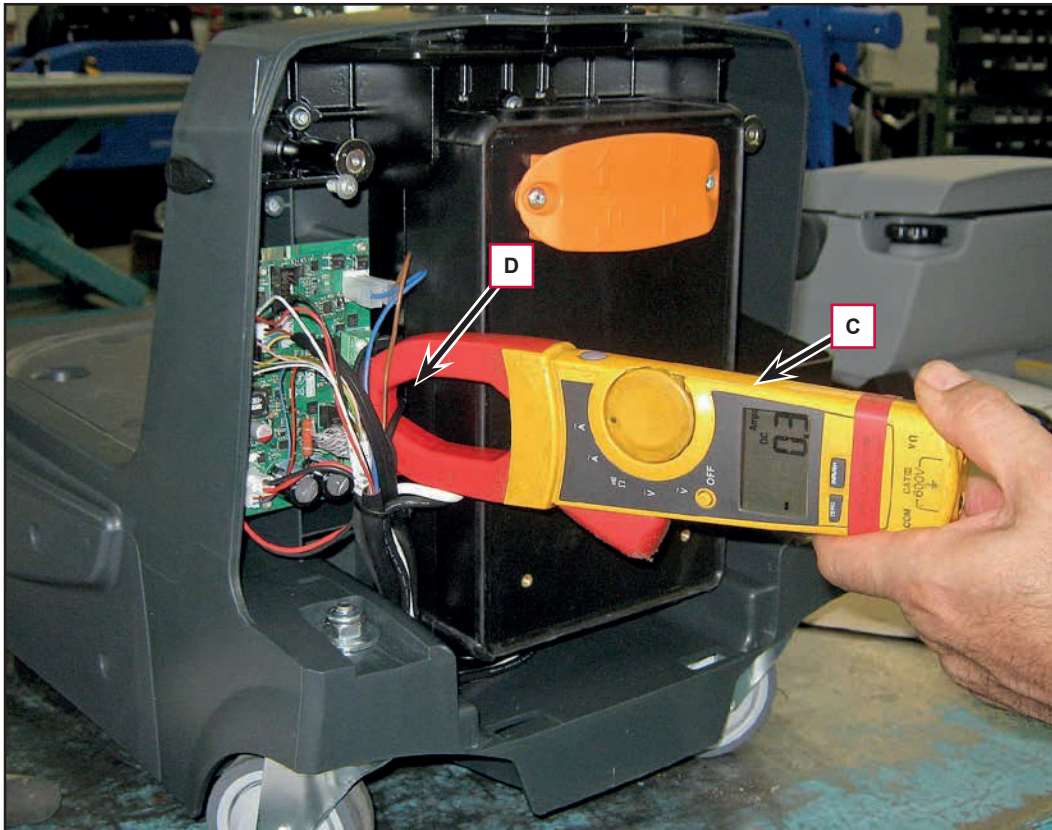

Figure 6

Removal and Installation

Driving Belt

Check

1. Remove the tank assembly from the machine.
2. Open the rear cover and remove the battery.
3. Remove the cylindrical brush.
4. Remove the 4 screws (A) and remove the protective casing on the transmission (B).
5. Visually inspect the entire length of the belt (C) to make sure it is intact and shows no signs of cuts, tears or cracks; replace if necessary.
6. Check the tension of the belt (C) between motor and brush using the TEN-SIT (D) device: When deflecting the centre of the belt (E), the tool should measure a value of $69\text{Hz} \pm 10$.

Belt tensioning

If necessary, tension the belt correctly (C).

7. Loosen the 3 screws (F) and adjust the position of the motor and pulley (G) as necessary. Once the correct tension of the belt has been applied, tighten the 3 screws (F).

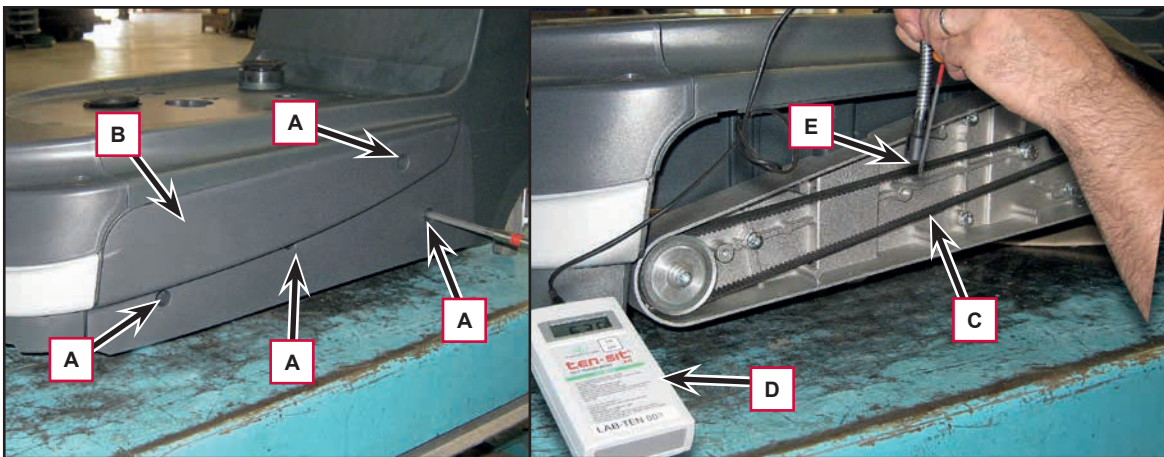

Figure 7

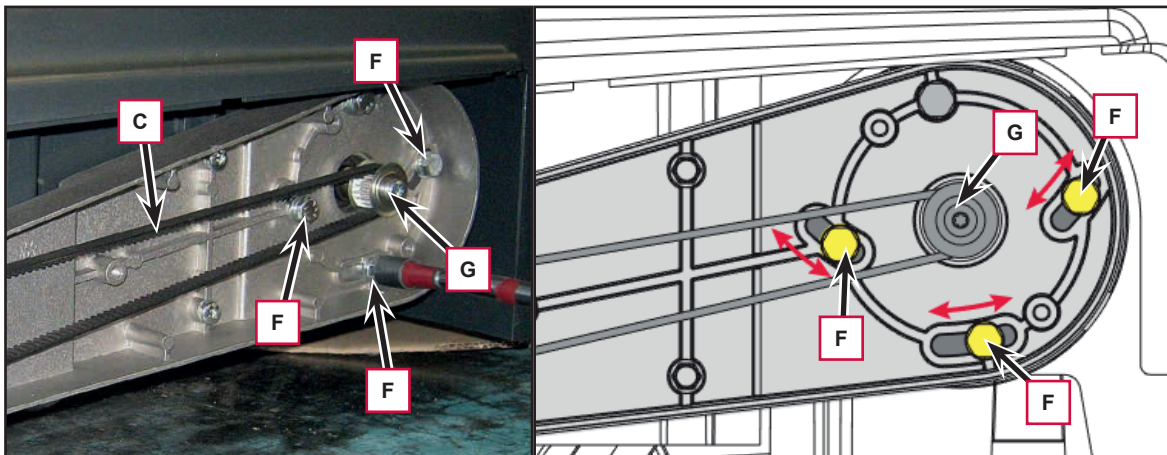

Figure 8

Driving Belt (continues)

Replacement

- If the belt (C) requires replacement, loosen the 3 screws (F) and move the brush motor and pulley (G) to loosen the belt, then replace it.
- Tension the belt (see the procedure given above).

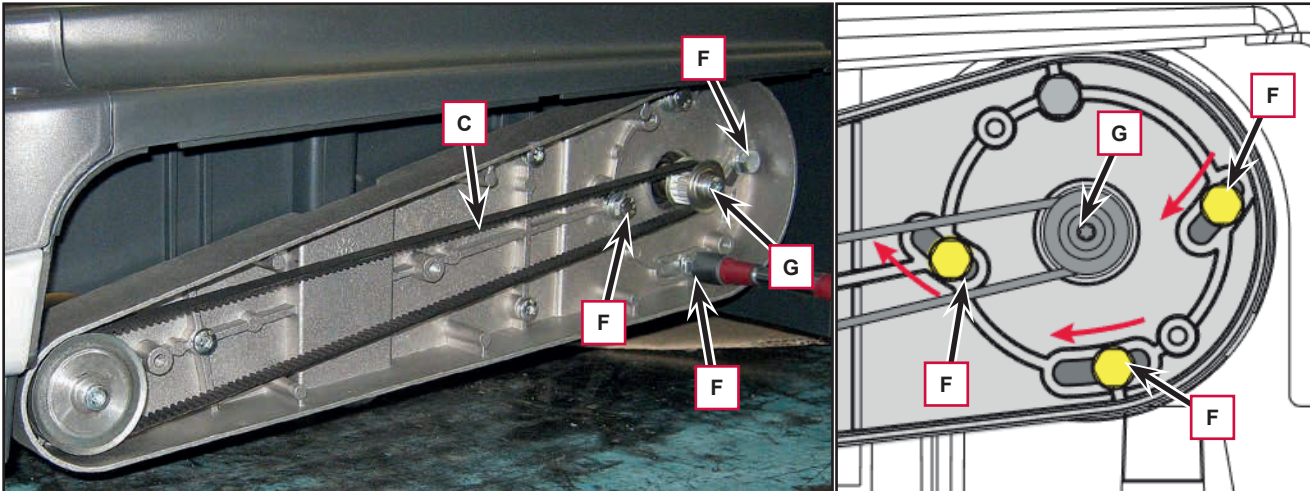

Figure 9

Reassembly

- Perform steps 1 to 4 in the reverse order.

Brush Motor

Removal

1. Remove the tank assembly from the machine.
2. Open the rear cover and remove the battery.
3. Remove the cylindrical brush.
4. Remove the screw to remove the controller protective cover.
5. Disconnect the brush motor connections (A).

- Do not loosen the connection fastening screws, use a pair of pliers to hold the connector on the controller .

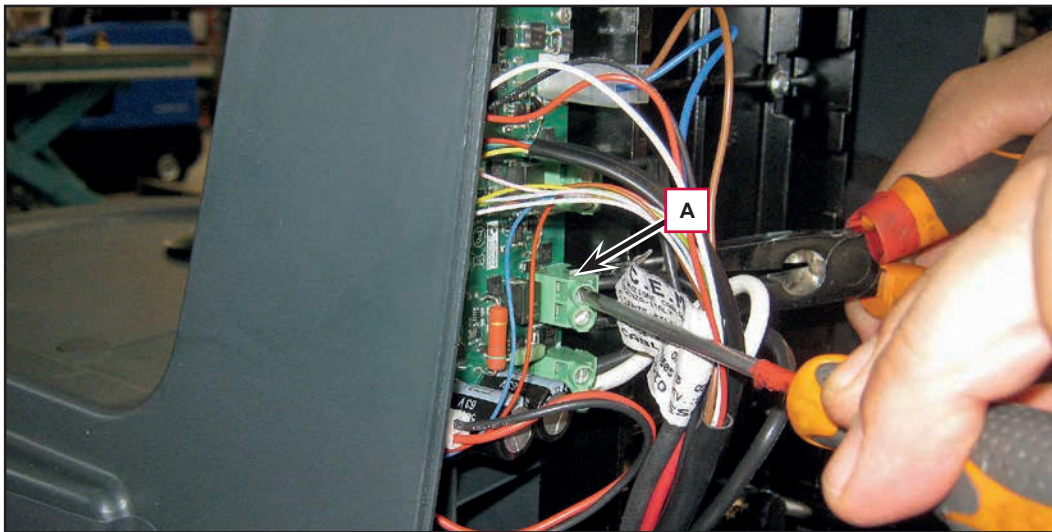

Figure 10

6. Remove the two cable retention clamps (B).

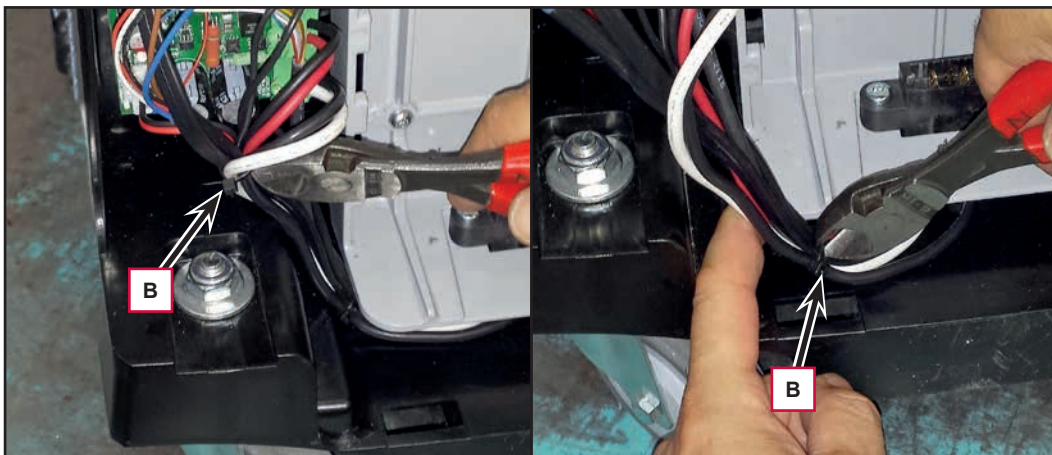

Figure 11

Brush Motor (continues)

7. Remove the 7 caps (C) and remove the 7 screws (D), then remove the upper cover from the machine body (E).

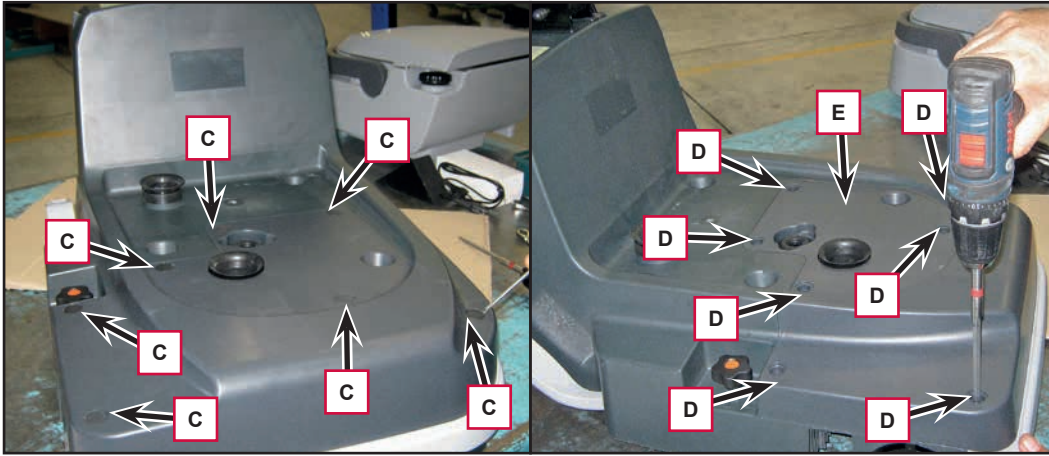

Figure 12

8. Remove the screw (F), keeping the inner locknut (G) held in position. Remove the 2 screws (H), keeping the inner locknuts (I) held in position.

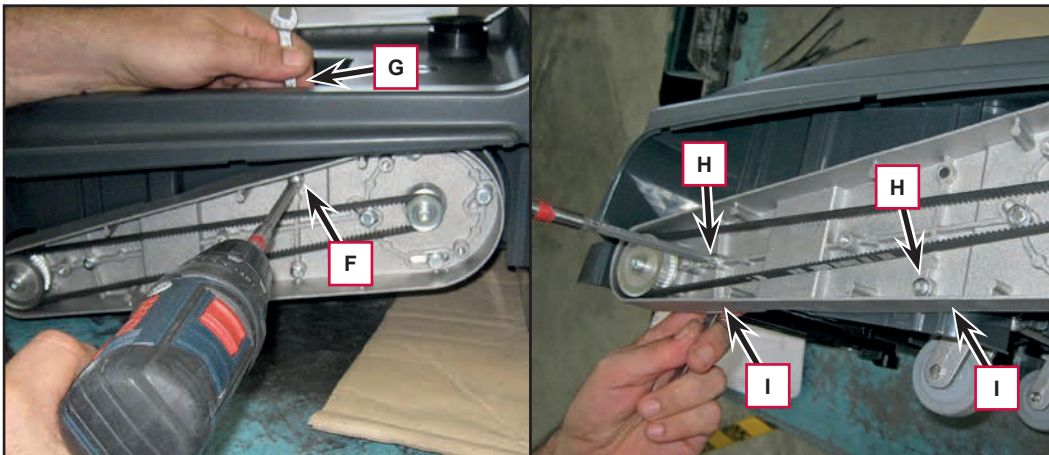

Figure 13

9. Working underneath the machine, remove the clamp (J) and extract the wiring. Remove the motor and transmission assembly (K) from the machine.

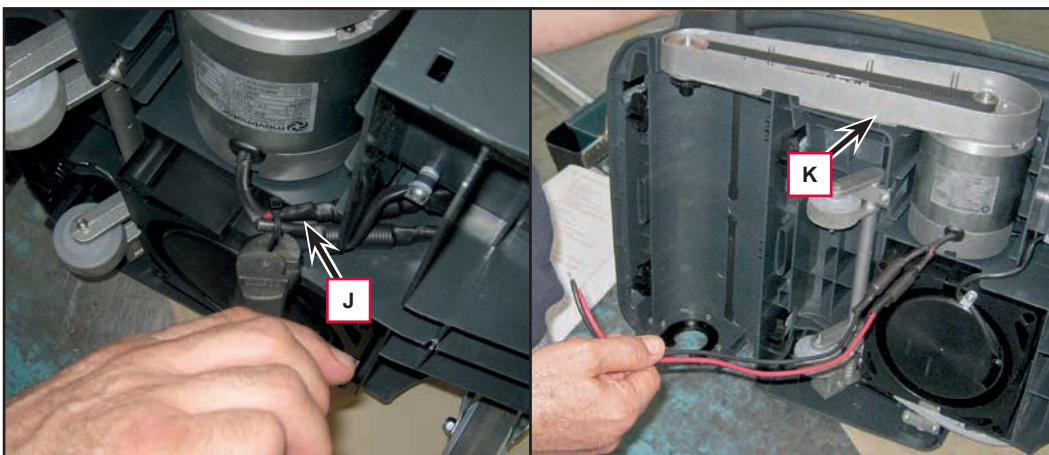

Figure 14

Brush Motor (continues)

- Working at the workbench, remove the 4 screws (L), then remove the brush motor (M) from its support.

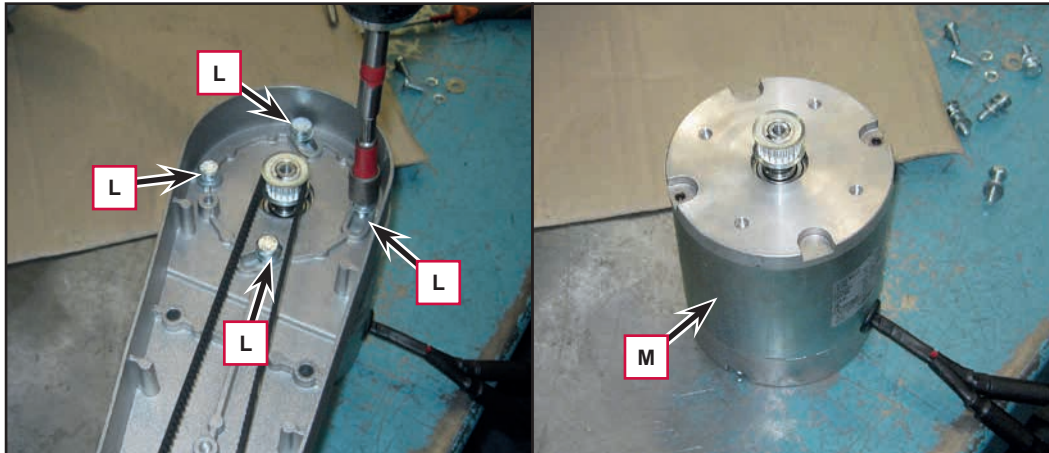

Figure 15

Installation

- Fit the brush motor on its support and tension the belt.
- During assembly on the machine, position the brush motor and keep it rotated as shown (N), then screw in and tighten the 3 screws (O) with the locknuts.

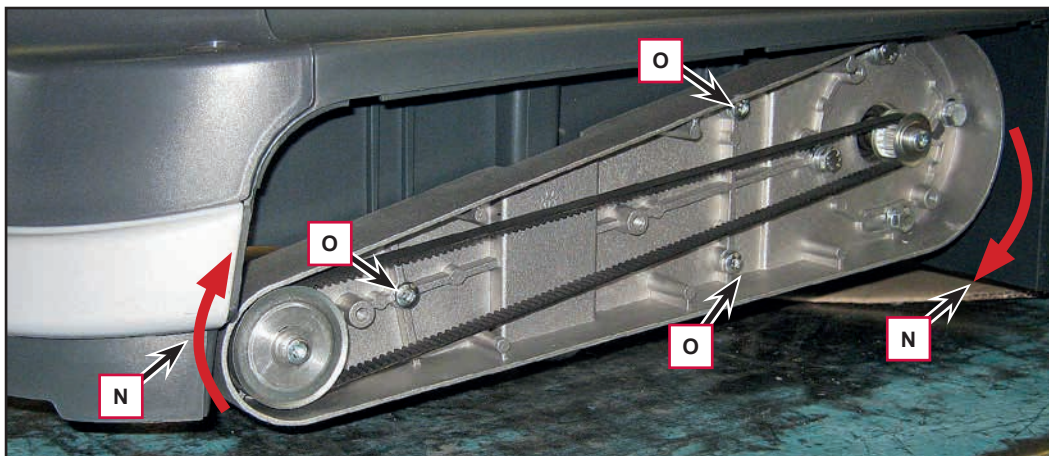

Figure 16

- Assemble the components in the reverse order of disassembly. Ensure the brush motor power supply cable polarity is correct on the connection to the main machine controller .

Specifications

Description / Model		Advance SC250, Clarke MA 30 Nilfisk SC250, Scrubtec 334
Cleaning width		13.4 in (340 mm)
Cylindrical brush diameter		3 in (80 mm)
Brush pressure on the ground		Max 26 lb (Max 12 Kg)
Brush motor technical data	Power	0.24 hp (180 W)
	Nominal speed	2000 ± 140 rpm
	Nominal current draw	7 ± 0.7 A
	Nominal torque	0.88 Nm
	No-load current	0.5 ± 0.3 A
	No-load speed	2450 ± 172 rpm
	Insulation class	B
	IP rating	IP20
Conductor and insulation materials		UL certified
Brush rotation speed		1,000 rpm

38 - Squeegee System

Functional Description

The squeegee system cleans the liquid off the floor, which is then collected by the recovery system.

The squeegee assembly (A) is attached to the machine body via two quick fix brackets fitted with springs, which allow the squeegees to adhere to and apply the correct pressure to the floor, even if it is not perfectly smooth and level.

Operating the right-hand lever on the handlebar lifts the front squeegee, allowing larger debris to be picked up. The mechanism also stops vacuuming at the lifted front squeegee (B), with a consequent increase in vacuuming at the rear squeegee.



Figura 1

Component Locations

- Squeegee assembly
- Quick coupling
- Integrated brackets with return spring for floor pressure
- Front right squeegee lifting lever
- Mechanism for front squeegee lifting and vacuum system stop

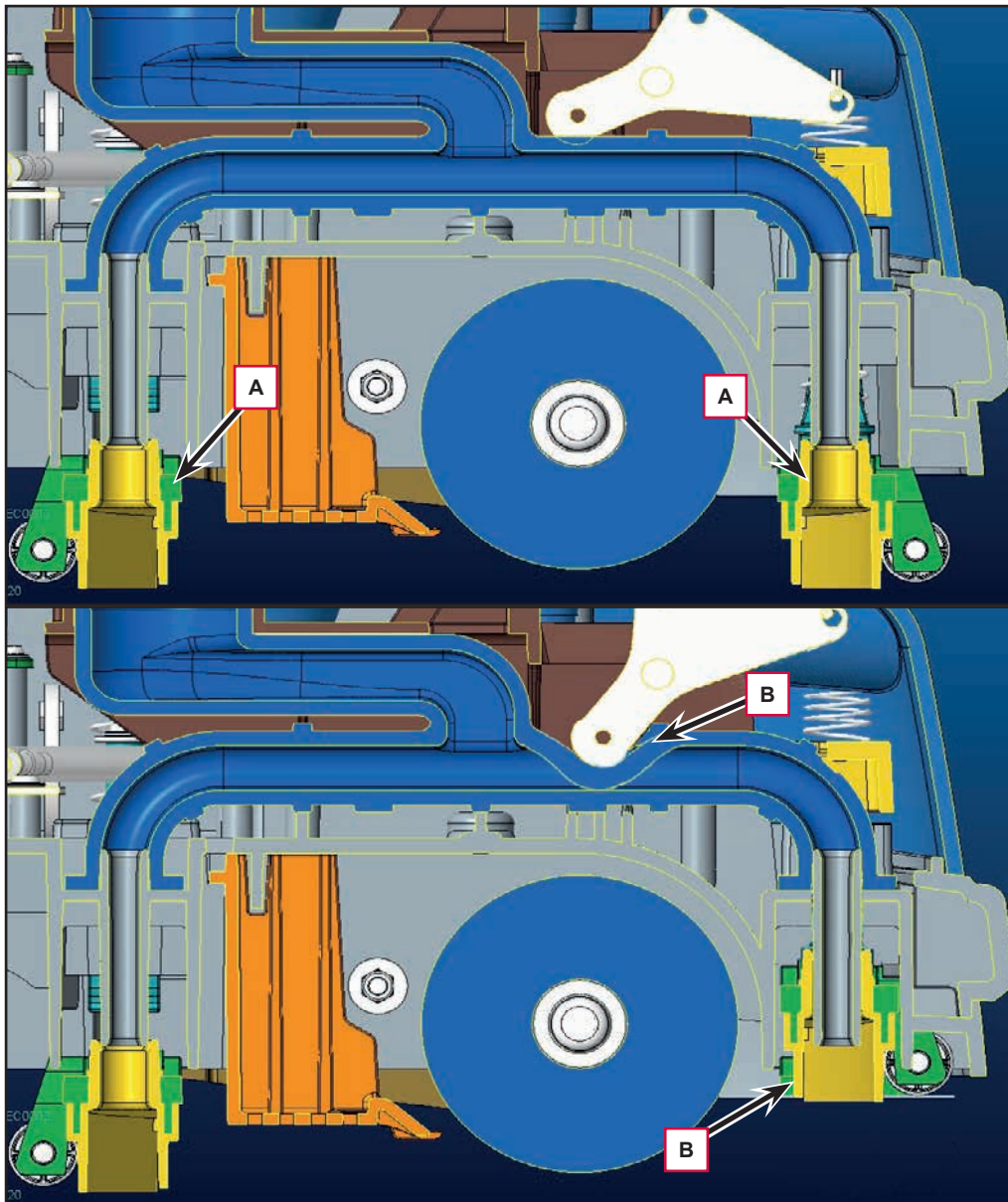
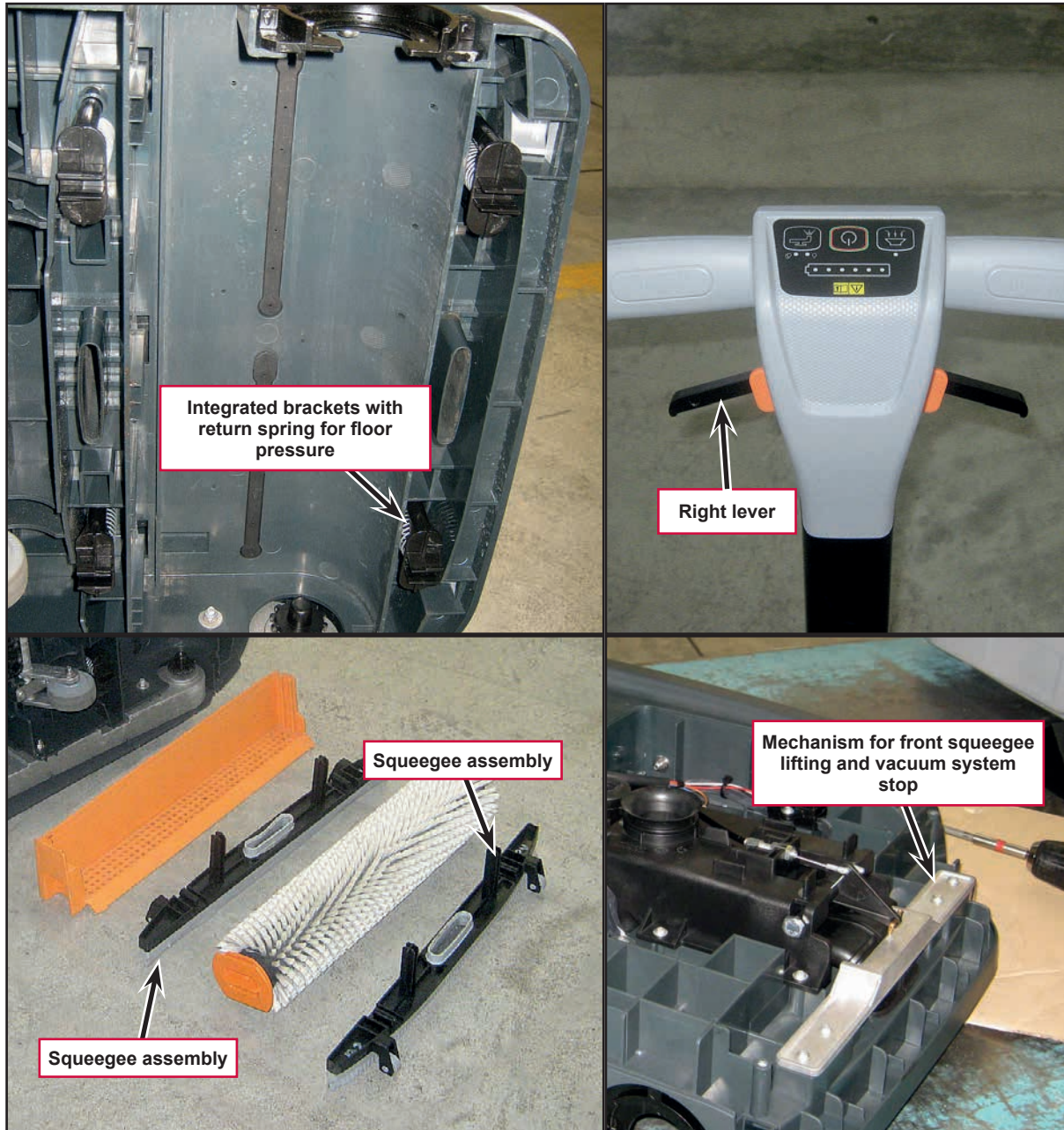

Figure 2

Maintenance and Adjustments

Squeegee Bar Cleaning



Note: *The squeegee bars must be clean and the blades must be in good conditions in order to get a good drying.*



Caution! *It is advisable to wear protective gloves when cleaning the squeegee bars because there can be sharp debris.*



Caution! *The squeegee bars are fastened to the machine with a snap system and can be easily removed.*

1. Ensure that the machine is off.
2. Remove the tanks container from the machine body using the handle.
3. Lift the machine body to access the lower part of the cleaning deck.
4. Remove the squeegee bars by pulling them outwards.
5. Clean and wash the squeegee bars. In particular, clean the compartments (A) and the vacuum hole (B). Check the blades for integrity, cuts and tears; if necessary replace the squeegee bars.
6. Before installing the squeegee bars, clean the recovery water ducts (C) thoroughly.
7. Install the squeegee bars and make sure they are properly engaged.

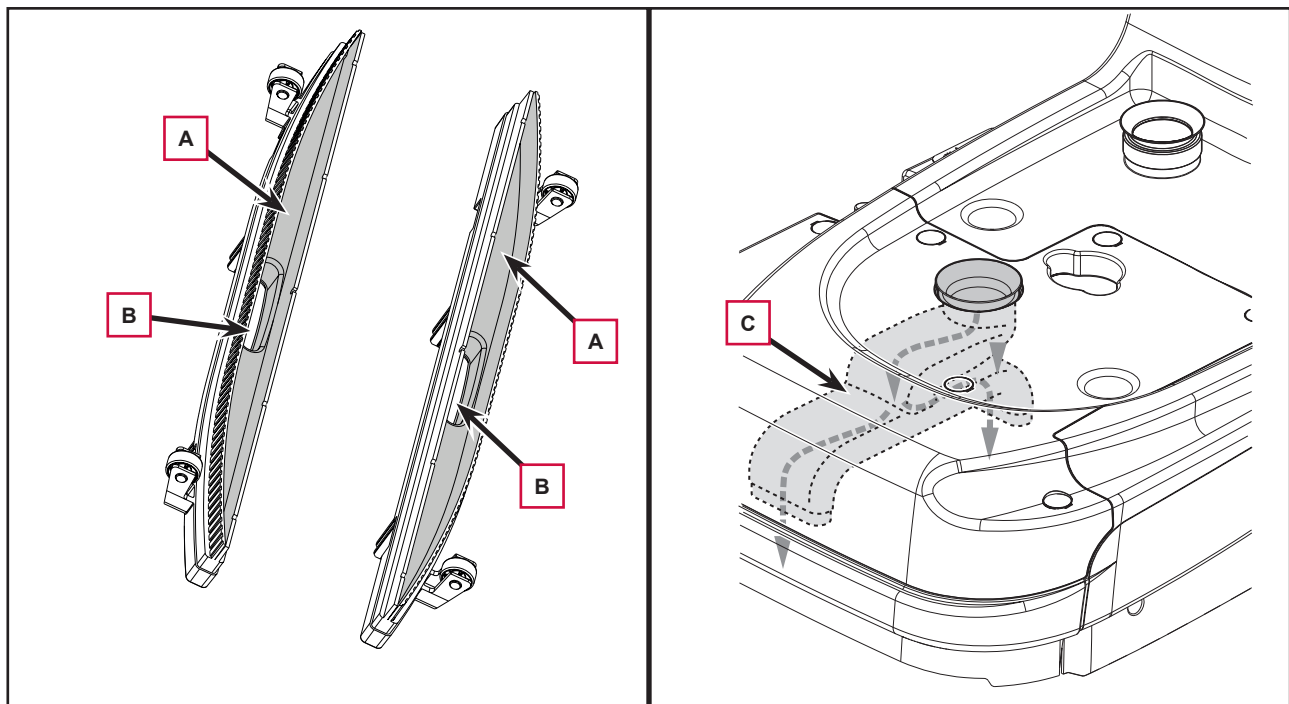

Figure 3

Troubleshooting

Trouble	Possible Causes	Remedy
Dirty water vacuuming is insufficient or there is no vacuuming.	The squeegee bars are dirty or the blades are worn or damaged.	Clean and check the squeegee bars.
The squeegees leave marks on the floor.	There is debris under the squeegee blades.	Remove the debris.
	The squeegee blades are worn, chipped or torn.	Replace the blades.
	Debris collection tank full.	Empty the tank.

Removal and Installation

Vacuum Duct

Removal

1. Remove the tank assembly from the machine.
2. Open the rear cover and remove the battery.
3. Remove upper cover from the machine body (A).



Figure 4

4. Loosen the nut and locknut (B) and remove the squeegee lifting cable (C).

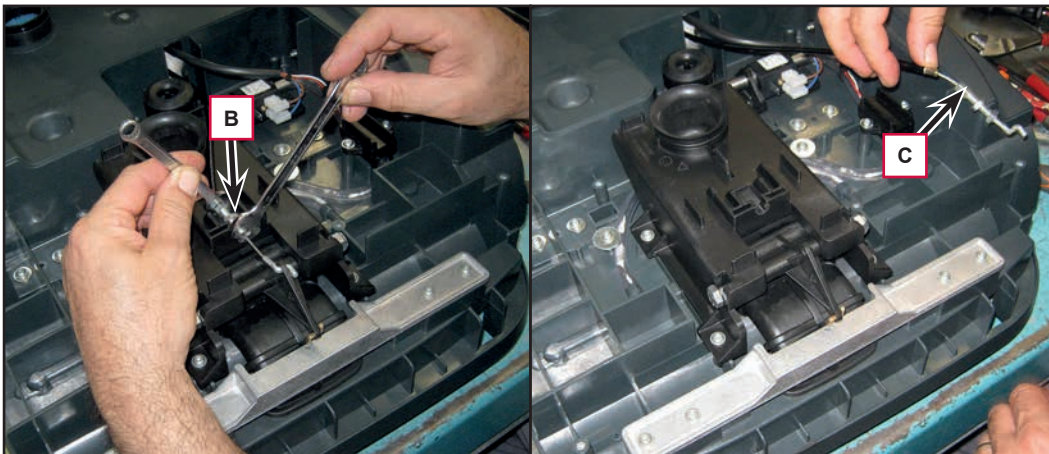

Figure 5

Vacuum Duct (continues)

5. Unscrew the 4 screws (D) and lift the vacuum duct bracket (E).

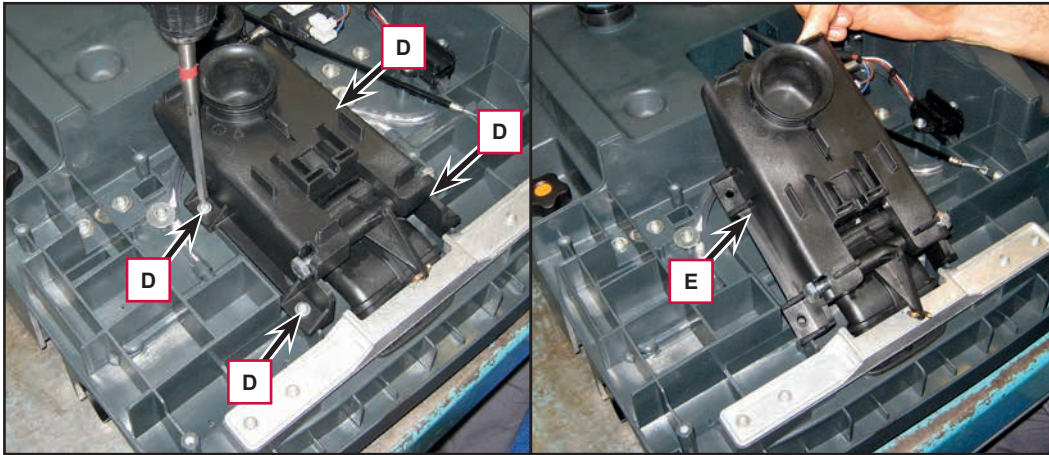

Figure 6

6. Free the front hook (F) from the linkage (G), then remove the vacuum duct bracket (E).
7. Remove the vacuum duct (H) and check that the openings are free of dirt and debris.

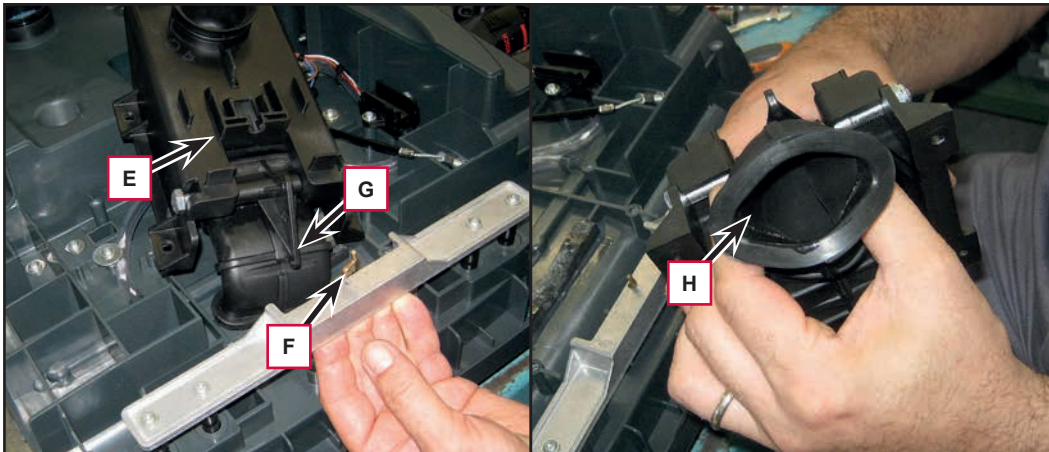

Figure 7

Vacuum Duct (continues)

Installation

8. Install the vacuum duct, making sure that the front (I) and rear openings (J) are correctly installed on the chassis.

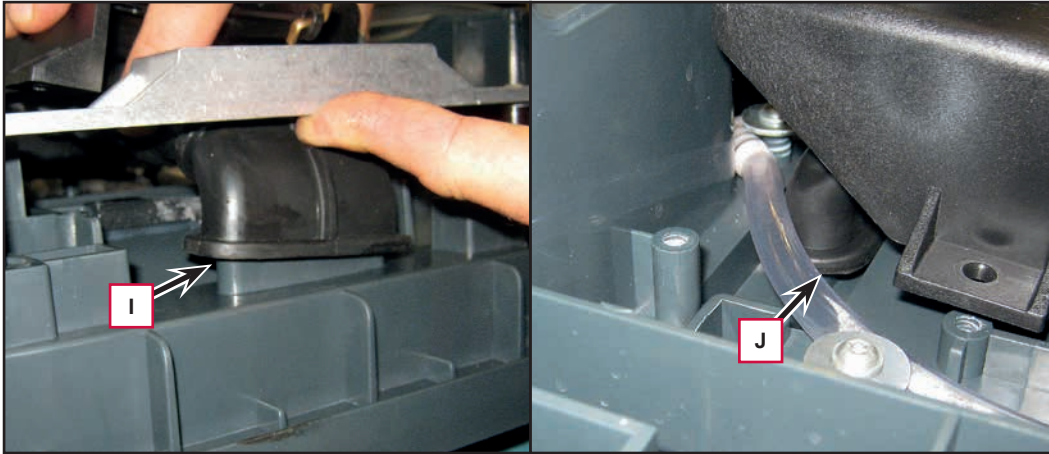

Figure 8

9. Fasten the front bar hook (K) to the squeegee lifting linkage (L), then fit the lifting cable (M), reinstalling the closing nut and locknut (N).

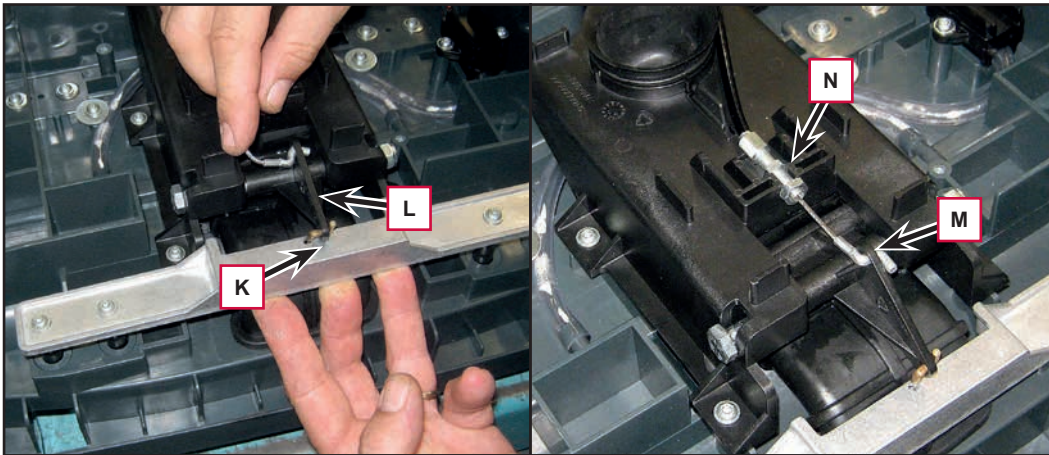

Figure 9

Vacuum Duct (continues)

10. Adjust squeegee lifting: Press the lifting lever and stop it with the orange push-button
11. The minimum height of the lifting bar must be ≥ 0.7 in (≥ 18 mm) (O). Adjust with the nut and locknut (N).

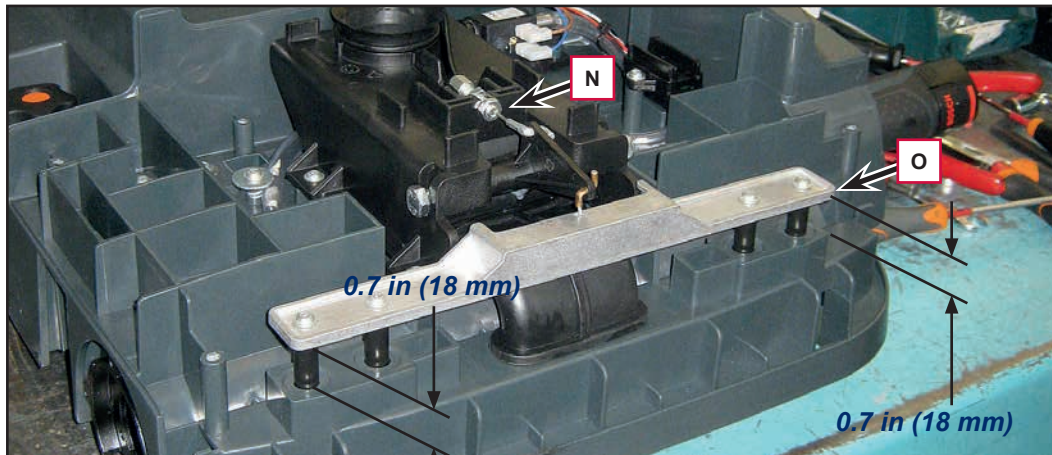

Figure 10

Specifications

Description / Model	Advance SC250, Clarke MA 30 Nilfisk SC250, Scrubtec 334
Squeegee width	14 in (360 mm)

40 - Recovery System

Functional Description

The recovery water system removes the dirty water from the floor and pipes it to a recovery tank. When the machine is running, the dirty water on the floor is collected by the squeegees assembly, and is directed through the slots in the blades into the vacuum duct and into the tank by the airflow created by vacuum system motor (M2).

The recovery tank is also part of the solution tank.

The collected dirty water is piped through two sleeves into the recovery tank, while the airflow continues to the vacuum fan.

The automatic float in the vacuum grid on the cover stops the vacuum system motor (M2) from collecting any liquid.

When the automatic float closes and stops the vacuum system, the vacuum system motor noise will increase and the floor will not be dried.

The gasket on the input of the vacuum system motor allows full functionality of the system, while the filter built in the gasket prevents the passage of dirt and debris.

The recovery water system is activated when the machine is switched on, and can be disabled or re-enabled by pressing the corresponding vacuum system

push-button .

Wiring Diagram

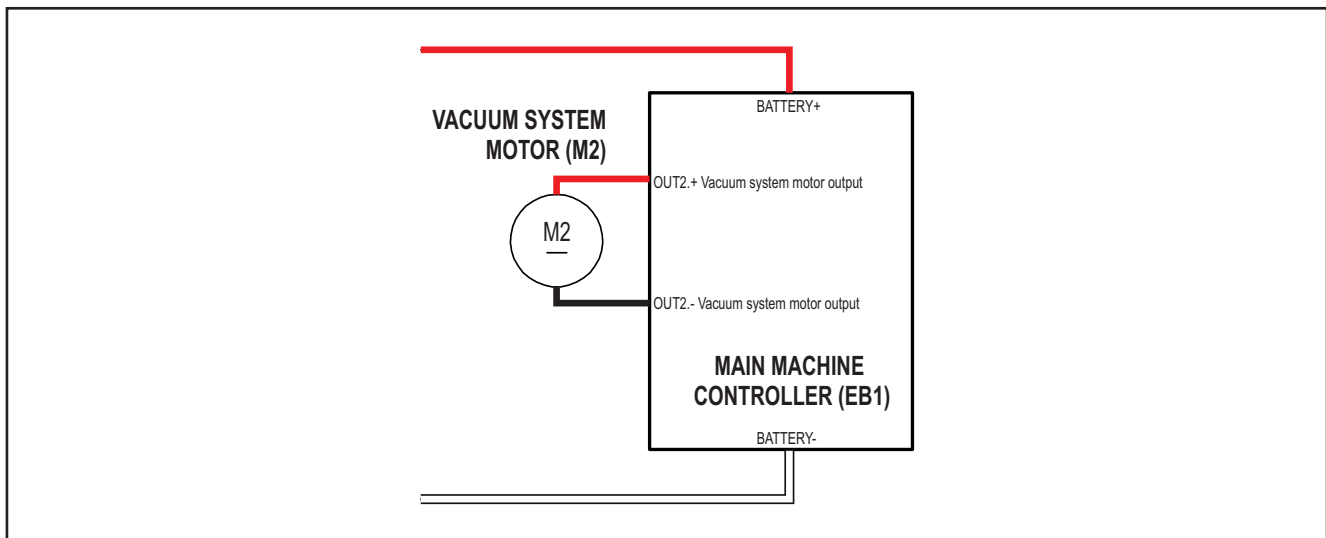

Figure 1

Component Locations

- Recovery tank assembly
- Vacuum sleeve from squeegee
- Vacuum sleeve from grid with automatic shut-off float
- Recovery tank cover
- Cover gasket
- Vacuum grid with automatic shut-off float
- Vacuum system motor (M2)
- Vacuum system motor gasket
- Vacuum system motor filter

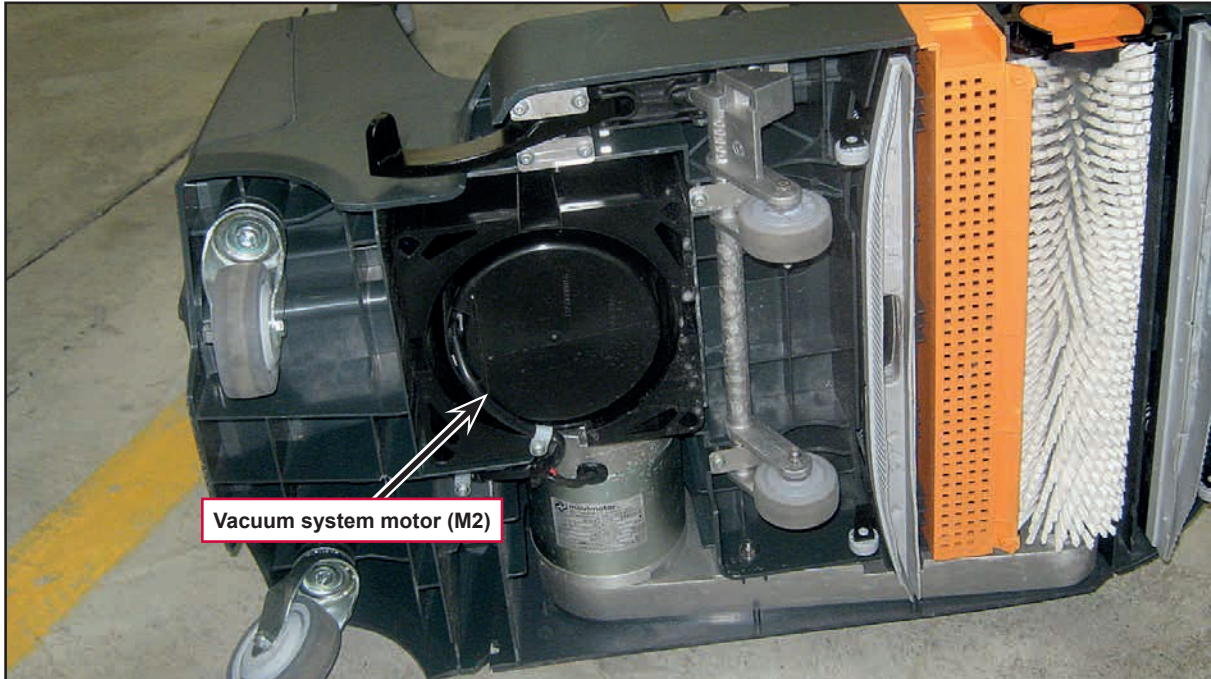

Figure 2

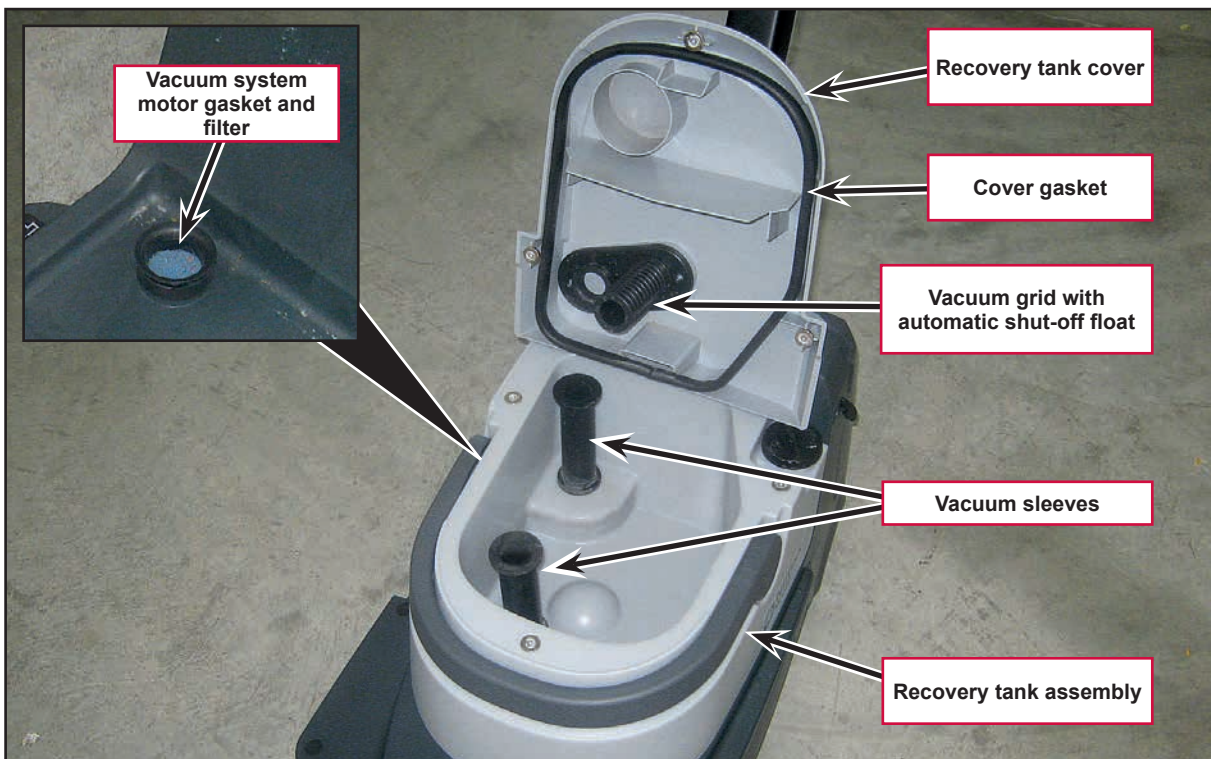

Figure 3

Maintenance and Adjustments

Recovery Tank and Cover Cleaning

1. Lift the tanks container from the machine body using the handle, and take it to the designated disposal area.
2. Drain the water from the tank.
3. Remove the cover (A) clean and wash the cover and the vacuum grid with water and detergent (B).
4. If necessary, remove the grid body (C) and float, than clean with care and reinstall.
5. Check the recovery tank cover gasket (D) for integrity.
6. If necessary, replace the gasket (D) by removing it from its housing on the cover. When assembling the new gasket, install the joint (E) in the area shown in the figure.
7. Check the air duct gasket (F) conditions. If necessary, replace the gasket.
8. Clean the tank compartment (G) with water and detergent, then rinse carefully.
9. Check that the seating surface (H) of the gasket (D) is clean and adequate for the gasket itself.
10. Reassemble the components.



Note:

The gasket (D) creates the vacuum in the tank that is necessary to vacuum up the recovery water.



Figure 4

Air Filter, Gaskets and Recovery Water Duct Cleaning

1. Remove the tanks container from the machine body using the handle.
2. Remove the air filter (A) and clean it.
3. Refit the filter in the housing of the gasket (B).



Note: The gaskets (B) and (C) allow the creation of the vacuum in the system which is necessary to collect the recovery water.

4. Check and clean the gasket (B) of the vacuum system motor.
5. Check and clean the recovery water duct gasket (C).



Figure 5

Troubleshooting

Trouble	Possible Causes	Remedy
The vacuum system motor will not turn on	Wiring between Main machine controller (EB1) and vacuum system motor (M2) damaged	Repair
	Main control board (EB2) faulty	Replace
	Vacuum system motor faulty	Check the current draw/Replace
Dirty water vacuuming is insufficient or there is no vacuuming.	Activation of automatic float shut-off	Drain the recovery tank
	Vacuum grid with automatic shut-off float dirty	Clean
	Tank cover not correctly positioned	Adjust
	Tank cover gasket damaged or not working correctly	Clean or replace
	The recovery water duct is dirty	Clean the duct with running water
	The vacuum system motor container is dirty	Clean
	Vacuum seals damaged or not working correctly	Repair or replace
	The air filter is dirty	Clean the filter

Vacuum System Motor Amperage Test



Warning! This procedure must be performed by qualified personnel only.

1. Open the rear cover on the battery compartment.
2. Remove the screw (A) and remove the main machine controller protective cover (B).

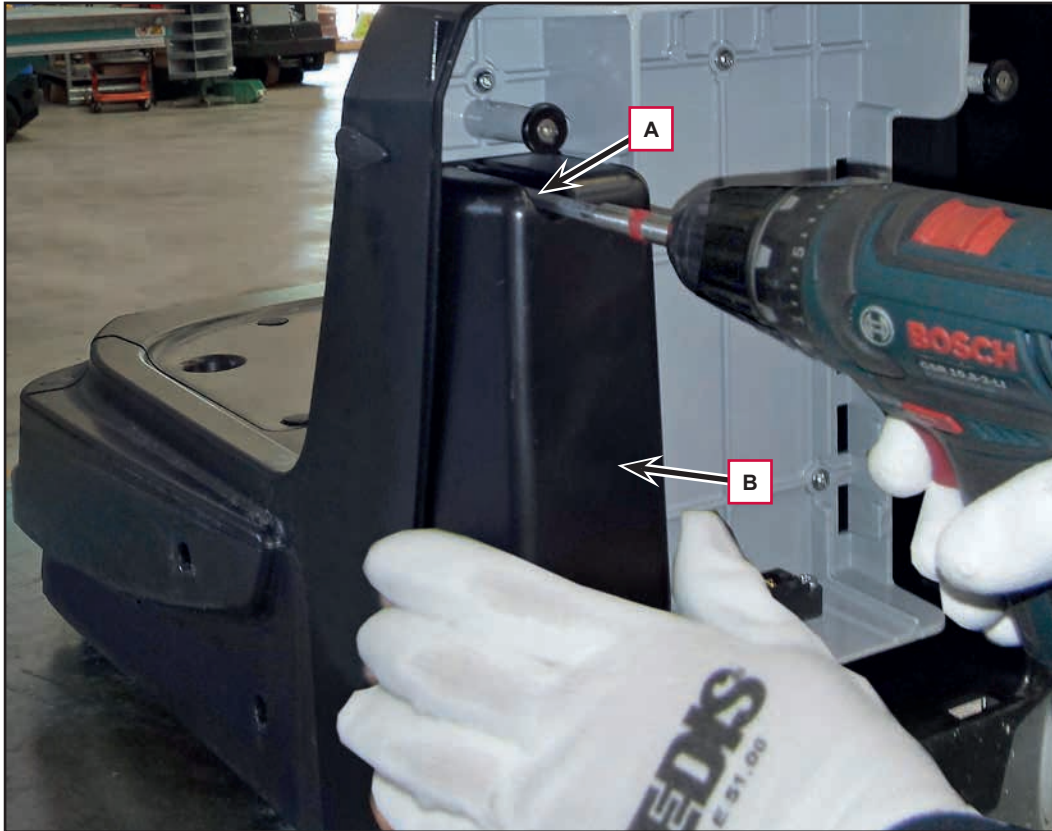

Figure 6

Vacuum System Motor Amperage Test (continues)

3. Apply the amp clamp (C) to the electrical cable (D) of the vacuum system motor.
4. Switch on the machine and operate it with one hand on the handlebar.
5. Check that the vacuum system motor current draw is between 5.5 and 6.5 A at 36 V.
6. If the current draw is higher, remove the vacuum system motor (see the procedure in the Vacuum System Motor Disassembly/Assembly paragraph), and check the condition of all its components to detect and correct the reason for the abnormal current draw:

If the above-mentioned procedures do not produce the correct readings for the vacuum system motor current draw, the motor must be replaced.

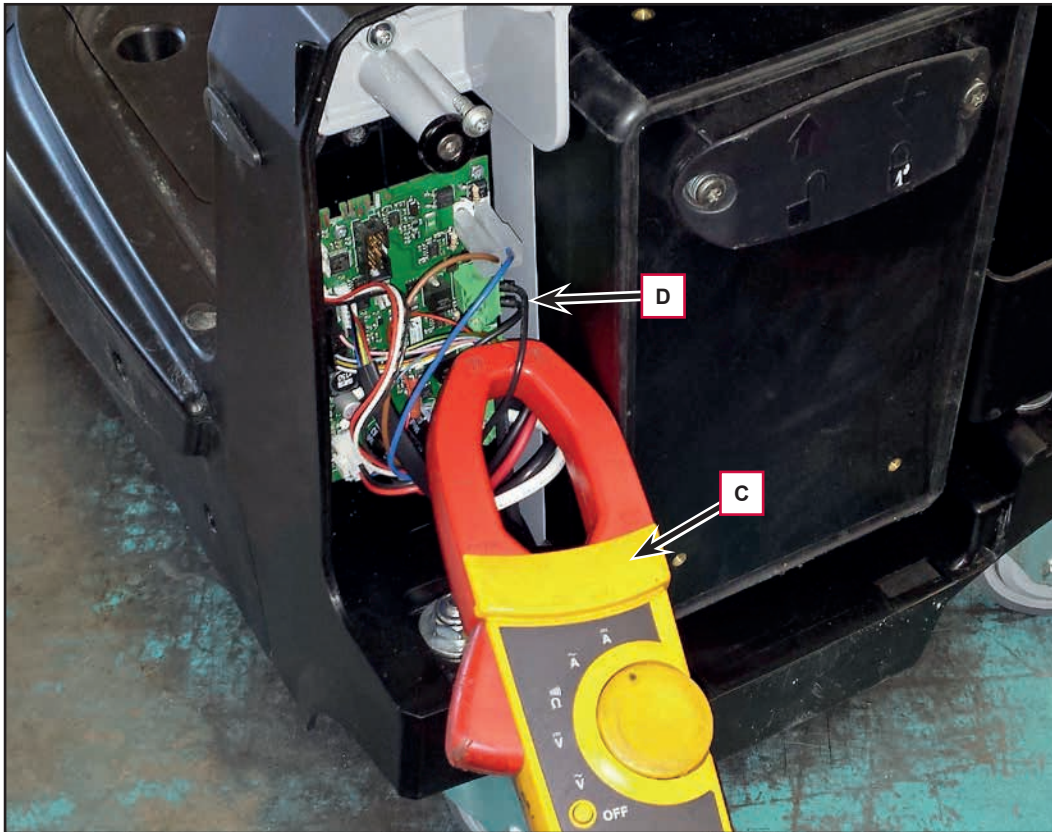

Figure 7

Removal and Installation

Vacuum System Motor

Removal

1. Remove the tank assembly from the machine.
 2. Open the rear cover and remove the battery.
 3. Remove the screw to remove the controller protective cover.
 4. Disconnect the vacuum motor connections (A).
- Do not loosen the connection fastening screws, use a pair of pliers to hold the connector on the controller.

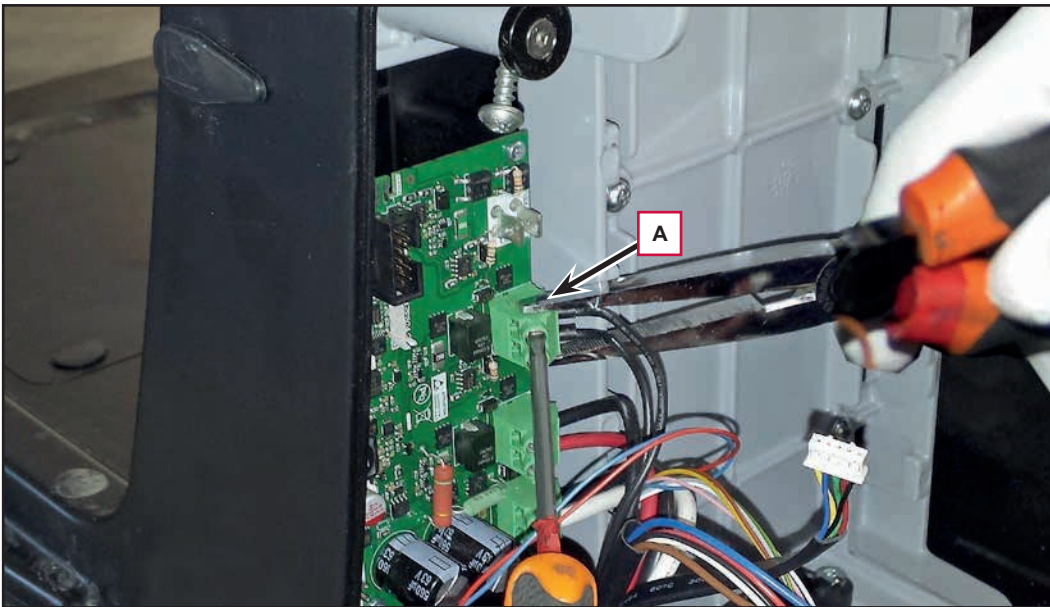

Figure 8

5. Remove the two cable retention clamps (B).



Figure 9

Vacuum System Motor (continues)

6. Turn the machine over onto its right side to access the lower area.
7. Remove clamp (C) and clamp (D) to free up the wiring.

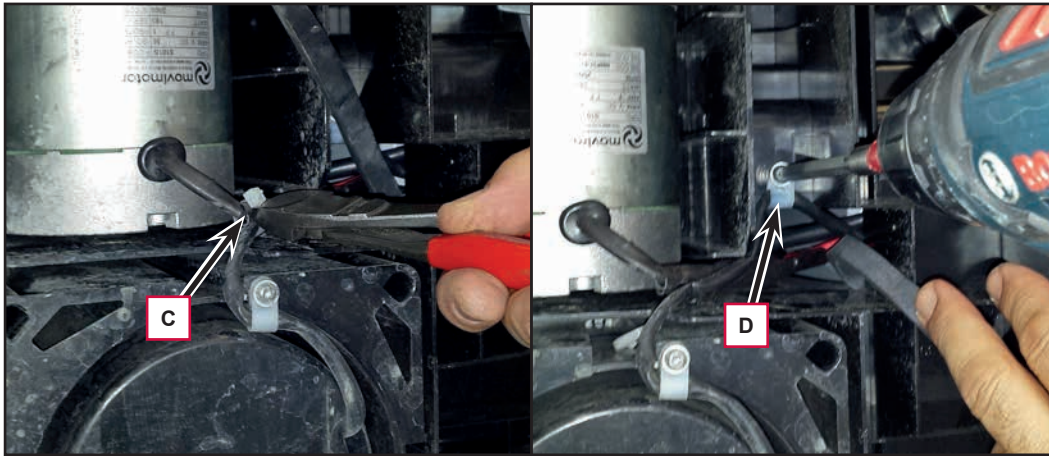

Figure 10

8. Remove the wiring (E) from the machine.
9. Unscrew the 4 retaining screws (F) and remove the vacuum motor unit (G) from the machine.

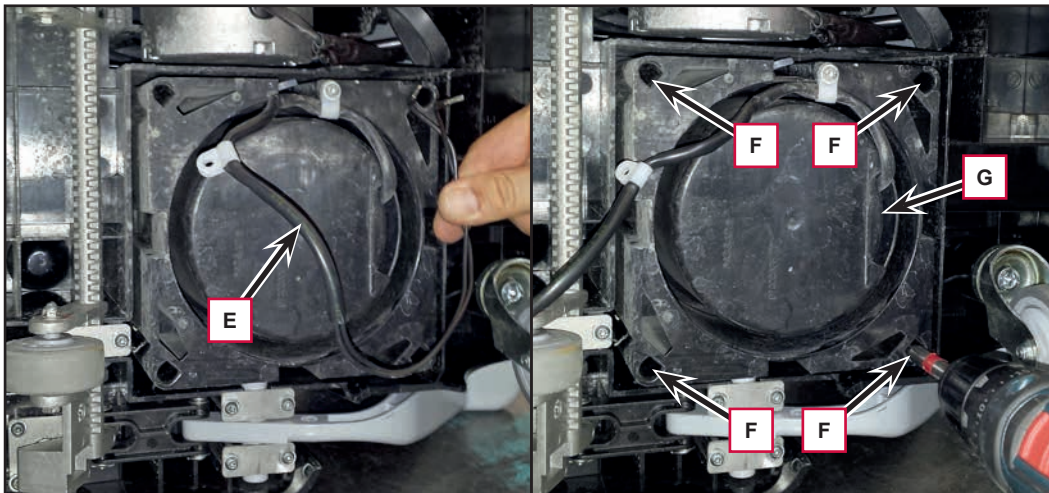

Figure 11

Vacuum System Motor (continues)

Disassembly

10. At the workbench, unscrew the 4 screws (H), then carefully rotate the vacuum system assembly.

11. Remove the clamp (I).

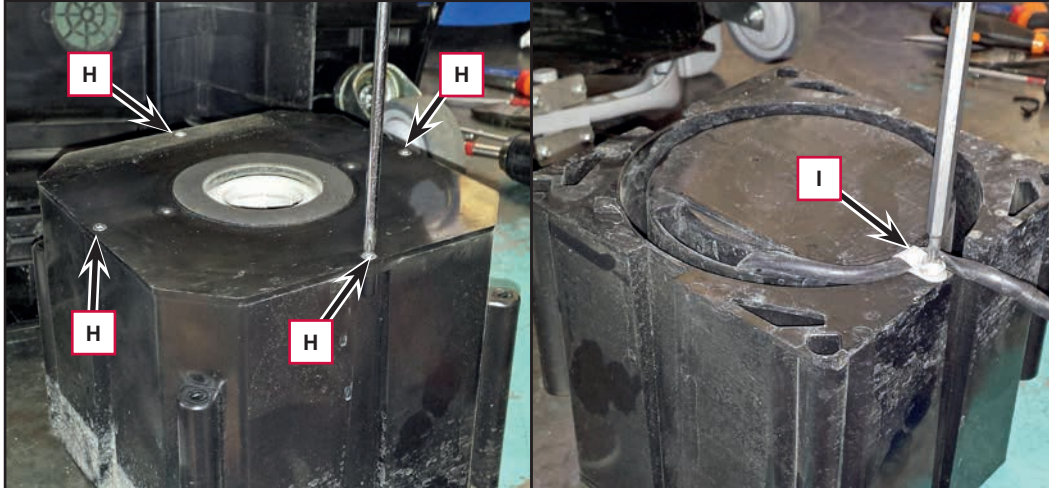

Figure 12

12. Lift the outer container (J) out of the inner container (K), then extract the motor (L).

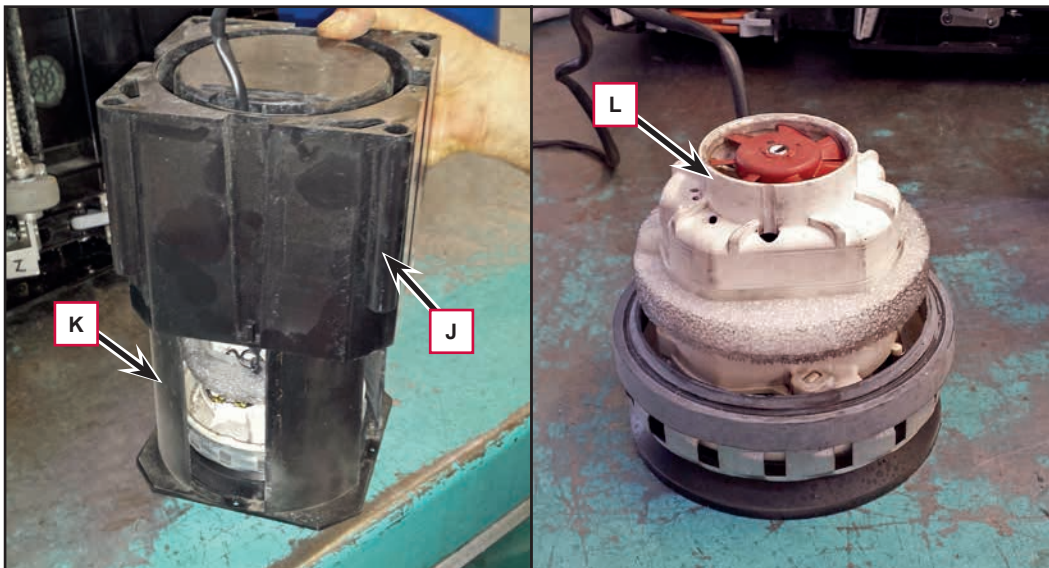

Figure 13

Vacuum System Motor (continues)

13. Save the gaskets (M) and (N).

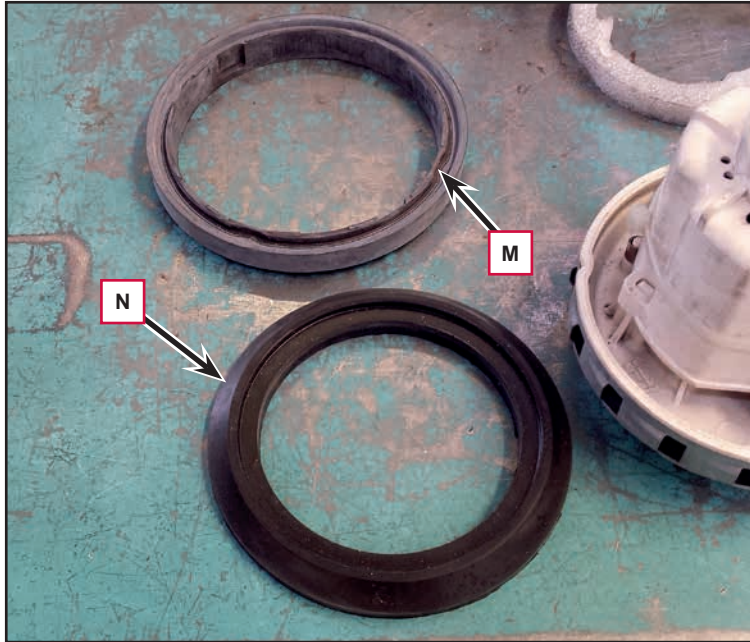

Figure 14

14. Remove the save the clamp (O) and the dividing sponge (P), then disconnect the connections (Q).

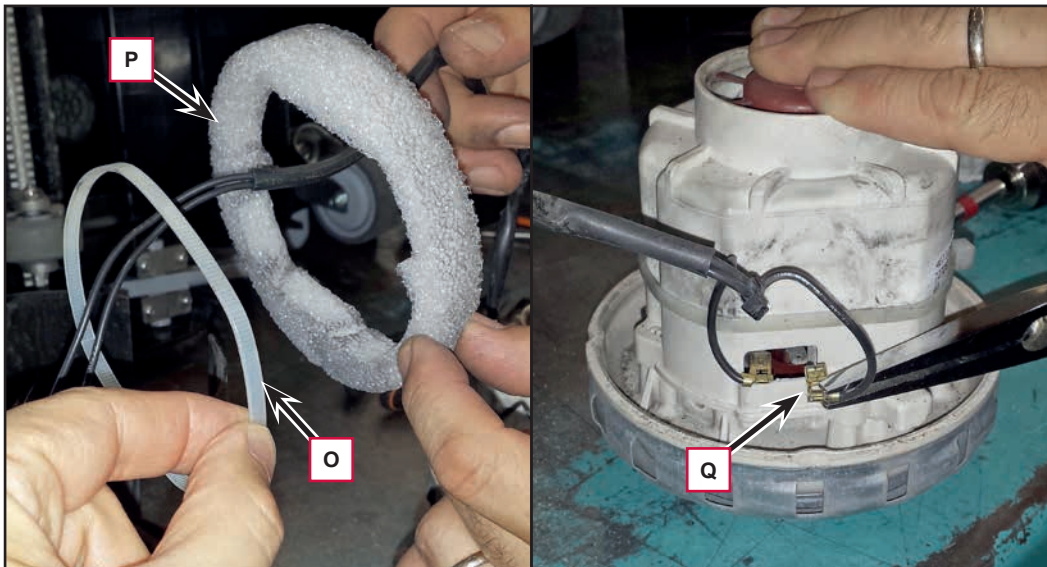

Figure 15

15. Clean the inside of the containers to remove any dirt which has accumulated, and check all gaskets for wear; replace if necessary.

Vacuum System Motor (continues)

Assembly

16. Position the gasket (M) on the vacuum system motor. Check that the gasket is reassembled with the correct orientation (slots).
17. Install the clamp (R). The clamp must be positioned at 2.2 in (55 mm) from the upper surface, around the entire circumference.

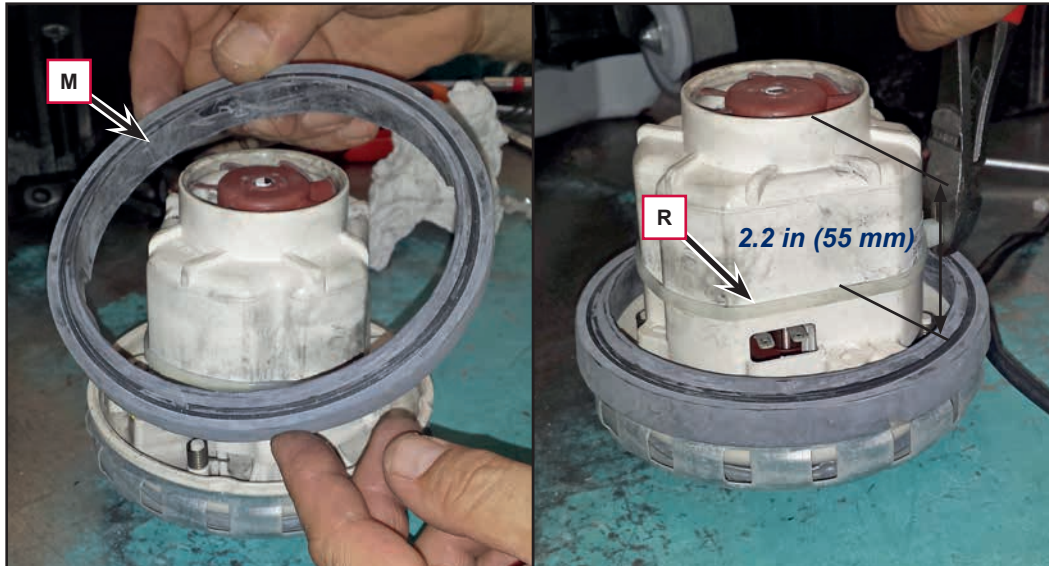

Figure 16

18. Connect the power connections (Q) and position the gasket (N) below the vacuum system motor. Check that the gasket is reassembled with the correct orientation.
19. Position the sponge ring (P) flush against the clamp (R). Check that the wiring is inside the sponge ring and that the sponge is correctly oriented.
20. Position the clamp (O) together with the wiring.

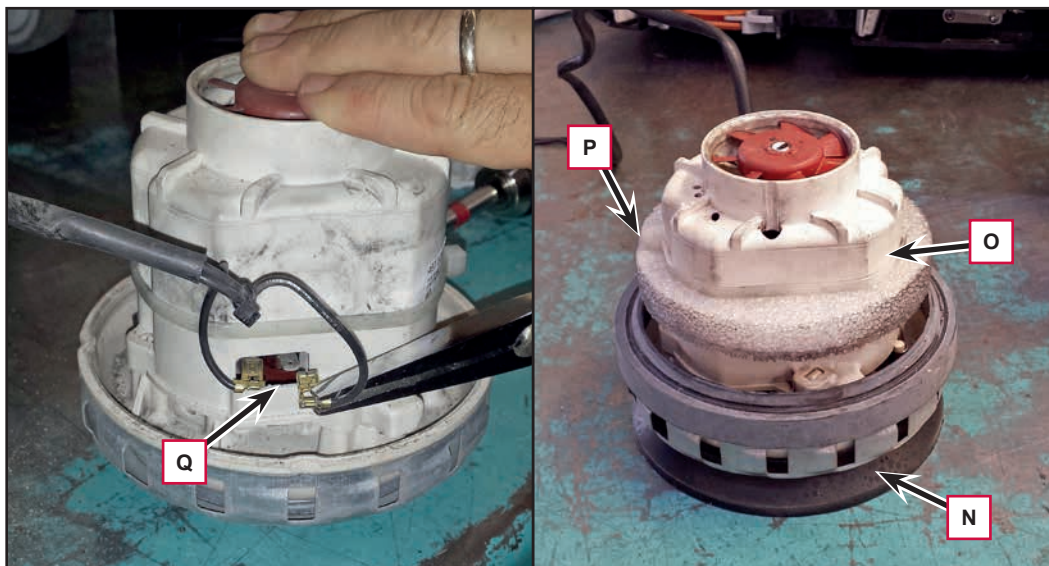

Figure 17

Vacuum System Motor (continues)

21. Run the wiring (E) inside the large hole in the outer container (J).
22. Insert the vacuum system motor in the outer container, as shown (S).

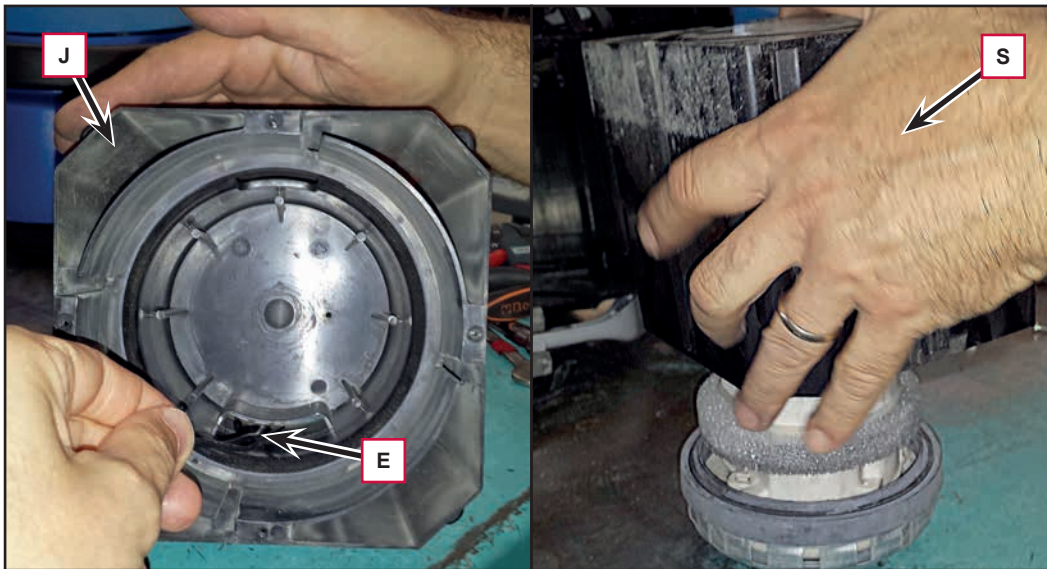

Figure 18

23. Rotate the outer container with the vacuum system motor. Check that the motor and gasket are positioned almost in line with the outer edge of the container.
24. Fit the inner container (K) and fasten it with the 4 screws.

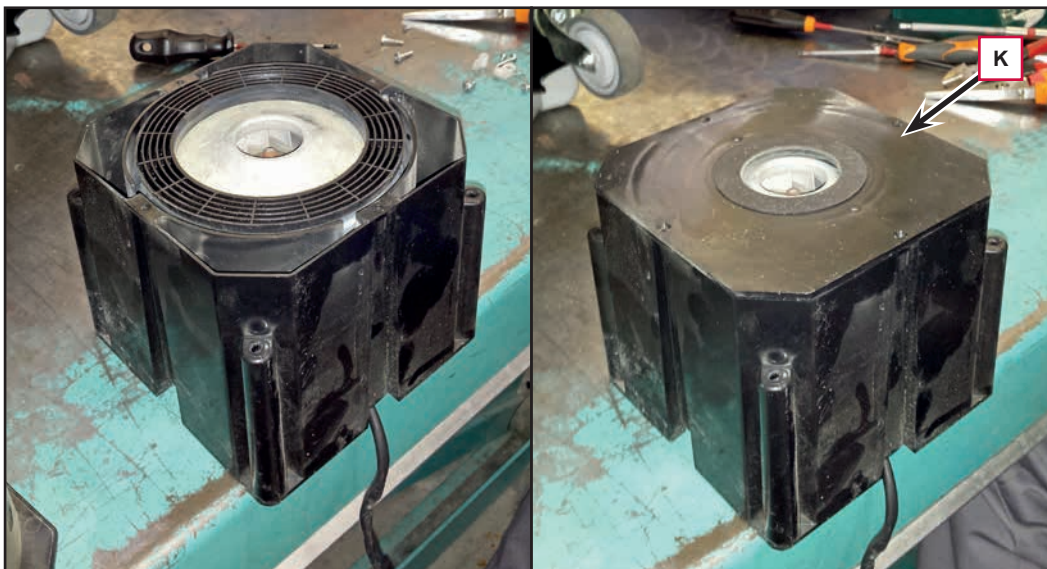

Figure 19

Installation

25. Continue to assemble the components in the reverse order of disassembly.

Specifications

Description / Model		Advance SC250, Clarke MA 30 Nilfisk SC250, Scrubtec 334
Recovery tank capacity		1.6 US gal (6 liters)
Vacuum system motor technical data	Power	0.24 hp (180 W)
	Maximum current	6 ±0.3 A
	Maximum air flow	38 ±2 dm ³ /s
	Vacuum with Ø16mm hole	5.05 ±0.35 kPa A
	Insulation class	H
	Impeller side bearing	CW (chemically resistant seal)
	Conductor and insulation materials	UL certified
Vacuum system capacity		2.13 ft H ₂ O (650 mm H ₂ O)

90 - Options

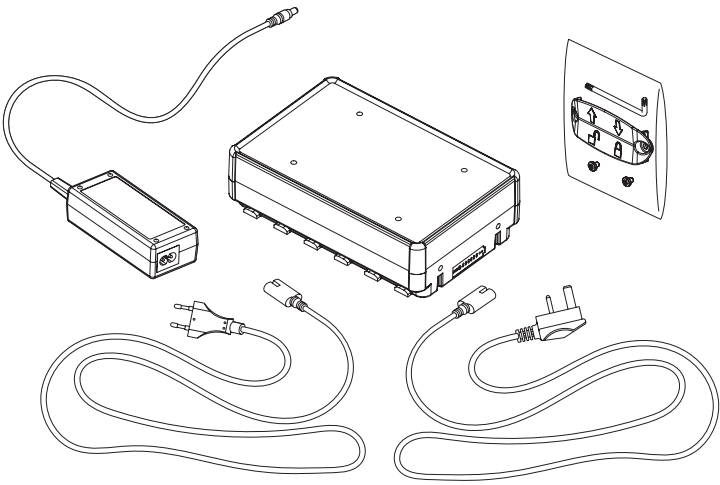
Description	Illustration
<p>BATTERY AND BATTERY CHARGER KIT (All versions)</p> <p>Battery Battery charger Power supply cables</p>	 <p>The illustration shows the following components: a rectangular battery pack, a battery charger unit, a power supply cable with a standard two-prong AC plug, a power supply cable with a different plug type, a power supply cable with a connector for the battery pack, and a battery pack cover with a latch mechanism.</p>