



Model Part No.:
608350
608351 - PAC

FALCON™ ULTRA B

BATTERY AUTOMATIC CARPET EXTRACTOR

OPERATOR AND PARTS MANUAL

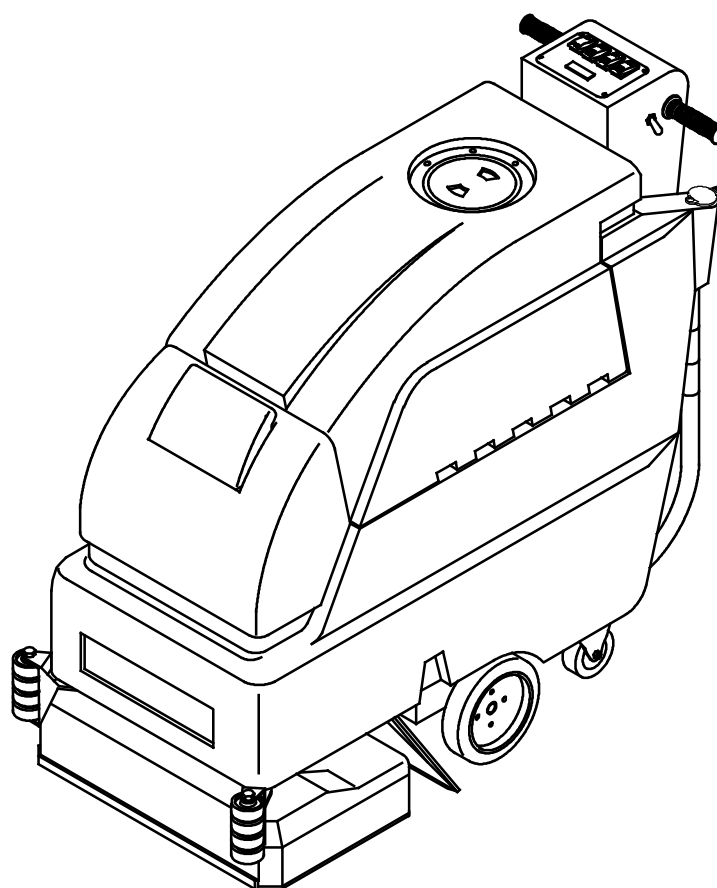

For the latest Parts manuals and other
language Operator manuals, visit:

www.nobles.com/manuals

www.nobles.com

608418
Rev. 06 (06-2014)



OPERATION

This manual is furnished with each new model. It provides necessary operation and maintenance instructions and an illustrated parts list.

Read this manual completely and understand the machine before operating or servicing it.

When ordering replacement parts, use the illustrated parts lists section in this manual. Before ordering parts or supplies, be sure to have your machine model number and serial number available. Parts and supplies may be ordered by phone or mail from any authorized parts and service center, distributor or from any of the manufacturer's subsidiaries.

This machine will provide excellent service. However, the best results will be obtained at minimum costs if:

- The machine is operated with reasonable care.
- The machine is maintained regularly - per the machine maintenance instructions provided.
- The machine is maintained with manufacturer supplied or equivalent parts.



PROTECT THE ENVIRONMENT

Please dispose of packaging materials, old machine components such as batteries, hazardous fluids such as antifreeze and oil, in a safe environmentally way according to your local waste disposal regulations.



Always remember to recycle.

Tennant Company

PO Box 1452

Minneapolis, MN 55440

Phone: (800) 553- 8033 or (763) 513- 2850

www.nobles.com

Specifications and parts are subject to change without notice.

Copyright ©1999, 2002, 2005, 2007, 2012, 2013, 2014

Tennant Company. All rights reserved. Printed in U.S.A.

Nobles is a registered United States trademark of Tennant Company.

MACHINE DATA

Please fill out at time of installation for future reference.

Model No.- _____

Install. Date - _____

Serial No.- _____

TABLE OF CONTENTS

SAFETY PRECAUTIONS	4	TROUBLE SHOOTING	18
SAFETY LABEL	5	SPECIFICATIONS	20
MACHINE COMPONENTS	6	MACHINE DIMENSIONS	21
CONTROL PANEL SYMBOLS	6	ELECTRICAL DIAGRAMS	22
MACHINE INSTALLATION	7	PARTS LIST	24
UNCRATING MACHINE	7	SOLUTION TANK GROUP	24
INSTALLING BATTERIES	7	RECOVERY TANK GROUP	
MACHINE SETUP	8	(S/N 10430222-)	26
FILLING SOLUTION TANK	8	RECOVERY TANK GROUP	
ADJUSTING CONTROL GRIP HEIGHT	8	(S/N 00000000- 10430221)	28
MACHINE OPERATION	9	CONSOLE GROUP	30
PRE- OPERATION CHECKS	9	CONTROL PANEL GROUP	32
WHILE OPERATING MACHINE	10	LIFT GROUP	34
CIRCUIT BREAKERS	10	DRIVE GROUP	36
OPTIONAL ACCESSORY TOOL SETUP AND		BRUSH BASE GROUP	38
OPERATION	10	SOLUTION GROUP	40
DRAINING TANKS	11	PUMP BREAKDOWN GROUP	42
DRAINING RECOVERY TANK	12	BATTERY AND CHARGER GROUP	43
DRAINING SOLUTION TANK	12	OPTIONS	44
BATTERY CHARGING	12	WAND GROUP, LOW PRESSURE,	
MACHINE MAINTENANCE	14	13 in / 330 mm	44
DAILY MAINTENANCE	14	WAND GROUP, LOW PRESSURE,	
MONTHLY MAINTENANCE	15	16 in / 406 mm	46
QUARTERLY MAINTENANCE	15	HAND TOOL, 5 in / 127 mm	48
BATTERY MAINTENANCE	16	HAND TOOL, CREVICE, 3 in / 76 mm	48
TRANSPORTING MACHINE	17	HAND TOOL, UPHOLSTERY,	
STORING MACHINE	17	LOW PRESSURE	49
RECOMMENDED STOCK ITEMS	17	HOSES, SOLUTION AND VACUUM	50
		PUMP- UP CARPET SPRAYER	50

OPERATION

SAFETY PRECAUTIONS

This machine is intended for commercial use. It is designed exclusively to clean carpets and upholstery in an indoor environment and is not constructed for any other use. Use only recommended accessory tools and commercially available carpet cleaners intended for machine application.

All operators must read, understand and practice the following safety precautions.

The following warning alert symbol and the "FOR SAFETY" heading are used throughout this manual as indicated in their description:

 **WARNING:** To warn of hazards or unsafe practices which could result in severe personal injury or death.

FOR SAFETY: To identify actions which must be followed for safe operation of equipment.

Failure to follow these warnings may result in personal injury, electrical shock, fire or explosion.

 **WARNING:** Fire Or Explosion Hazard:

- **Never Use Flammable Liquids Or Operate Machine in Or Near Flammable Liquids, Vapors Or Combustible Dusts.**

This machine is not equipped with explosion proof motors. The electric motors will spark upon start up and during operation which could cause a flash fire or explosion if machine is used in an area where flammable vapors/liquids or combustible dusts are present.

- **Do Not Pick Up Flammable Materials Or Reactive Metals.**
- **Batteries Emit Hydrogen Gas. Keep Sparks And Open Flame Away. Keep Battery Compartment Open When Charging.**

 **WARNING:** Electrical Shock Hazard. Disconnect Battery Cables Before Servicing Machine.

 **WARNING:** Spinning Brush. Keep Hands Away. Turn Off Power Before Working On Machine.

The following information signals potentially dangerous conditions to the operator or equipment:

FOR SAFETY:

1. **Do not operate machine:**
 - With flammable liquids or near flammable vapors as an explosion or flash fire may occur.
 - Unless trained and authorized.
 - Unless operation manual is read and understood.
 - If not in proper operating condition.
2. **Before operating machine:**
 - Make sure all safety devices are in place and operate properly.
 - Place wet floor signs as needed.
3. **When using machine:**
 - Go slow on inclines and slippery surfaces.
 - Use care when reversing machine.
 - Report machine damage or faulty operation immediately.
 - Never allow children to play on or around.
 - Follow mixing and handling instructions on chemical containers.
4. **Before leaving or servicing machine:**
 - Stop on level surface.
 - Turn off machine.
 - Set parking brake, if equipped.
5. **When servicing machine:**
 - Avoid moving parts. Do not wear loose jackets, shirts, or sleeves.
 - Disconnect battery connections before working on machine.
 - Wear protective gloves and eye protection when handling batteries or battery cables.
 - Avoid contact with battery acid.
 - Block machine tires before jacking up.
 - Use hoist or jack that will support the weight of the machine.
 - Do not power spray or hose off machine. Electrical malfunction may occur.
 - Use manufacturer supplied or approved replacement parts.
 - All repairs must be performed by a qualified service person.
 - Do not modify the machine from its original design.

6. When transporting machine:

- Turn machine off.
- Do not lift machine when batteries are installed.
- Get assistance when lifting machine.
- Use a recommended ramp when loading/unloading on/off truck or trailer.
- Use tie-down straps to secure machine to truck or trailer.
- Put brush/pick-up head in the lowered position.

SAFETY LABEL

The safety label appears on the machine in the location indicated. Replace the label if it is missing or becomes damaged or illegible.

WARNING LABEL - LOCATED ON TOP OF THE RECOVERY TANK.

⚠ WARNING	⚠ AVERTISSEMENT	⚠ ADVERTENCIA
   	<p>EXPLOSION, FIRE AND SHOCK HAZARD. AVOID INJURY.</p> <ul style="list-style-type: none"> • Do Not Use or Pick Up Flammable Materials. • Do Not Use Near Flammable Liquids, Vapors or Combustible Dusts. • Keep Sparks and Open Flame Away When Charging Batteries. Keep Battery Hood Open When Charging. • Disconnect Battery Cables and Charger Cord Before Servicing. 	<p>RISQUE D'EXPLOSION, D'INCENDIE ET DE DÉCHARGE. ÉVITEZ LES BLESSURES.</p> <ul style="list-style-type: none"> • N'utilisez Pas ou Ne Ramassez Pas de Matériaux Inflammables. • N'utilisez Pas Près de Liquides, Vapeurs ou Poussières Inflammables. • Éloignez les Sources d'Étincelles ou de Flamme Ouverte Lors du Chargement des Batteries. Laissez Ouvert le Capot du Compartiment des Batteries Lors de la Mise en Charge. • Débranchez les Câbles de Batterie et la Cordon du Chargeur Avant l'Entretien.
		<p>PELIGRO DE EXPLOSIÓN, FUEGO, DESCARGA EVITE LESIONES.</p> <ul style="list-style-type: none"> • No Use Ó Recoja Materiales Flammables. • No Use Cerca De Líquidos Flammables, Vapores Ó Materiales Combustibles. • Mantenga Chispas Y Fuego Alejados Mientras Carga Baterías. Mantenga Tapa De Batería Abierta Mientras Carga. • Desconecte Cable De Batería Y Cable Del Cargador Antes Del Mantenimiento. <p style="text-align: right; font-size: small;">1026386</p>



OPERATION

MACHINE COMPONENTS

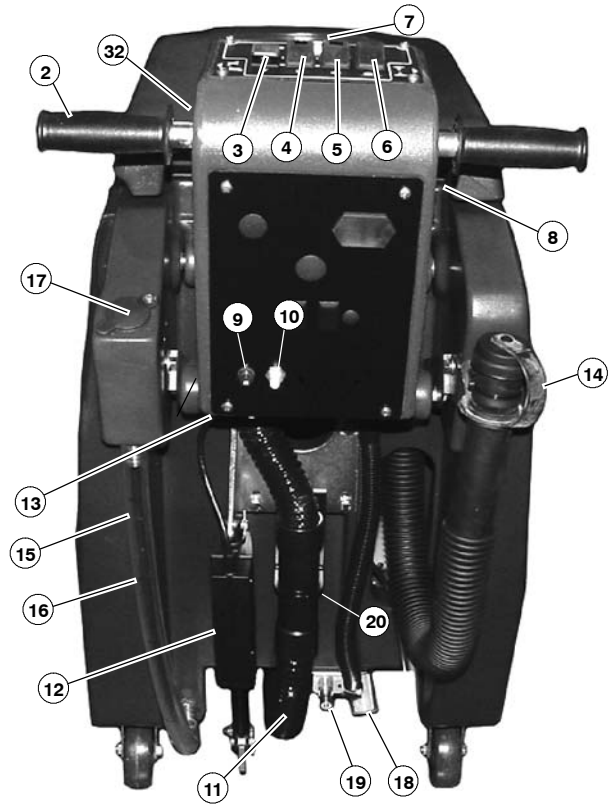

- | | | |
|--------------------------------------|---------------------------------------|-----------------------------|
| 1. Control Console | 12. Brush/Pickup Head Actuator | 23. Solution Tank |
| 2. Control Roll Grips | 13. Adjustable Control Console Levers | 24. Solution Tank Fill Door |
| 3. Main ON/OFF Switch | 14. Recovery Tank Drain Hose | 25. Battery Compartment |
| 4. Pump ON/OFF Switch | 15. Solution Tank Drain Hose | 26. Charger Plug |
| 5. Vacuum ON/OFF Switch | 16. 19L (5 Gal) Increment Markers | 27. Drive Wheels |
| 6. Brush/Pickup Head Actuator Switch | 17. Rear Fill Port | 28. Rear Casters |
| 7. Battery Meter | 18. Inline Solution Filter Strainer | 29. Wall Rollers |
| 8. Speed Control Knob | 19. Accessory Solution hose Coupler | 30. Pick-up Head |
| 9. Main/Pump/Brush Circuit Breaker | 20. Accessory Vacuum Hose Connector | 31. Brush Base |
| 10. Vacuum/Drive Circuit Breaker | 21. Recovery Tank | 32. Reverse Switch |
| 11. Intake Vacuum Hose | 22. Recovery Tank Lid | |

CONTROL PANEL SYMBOLS

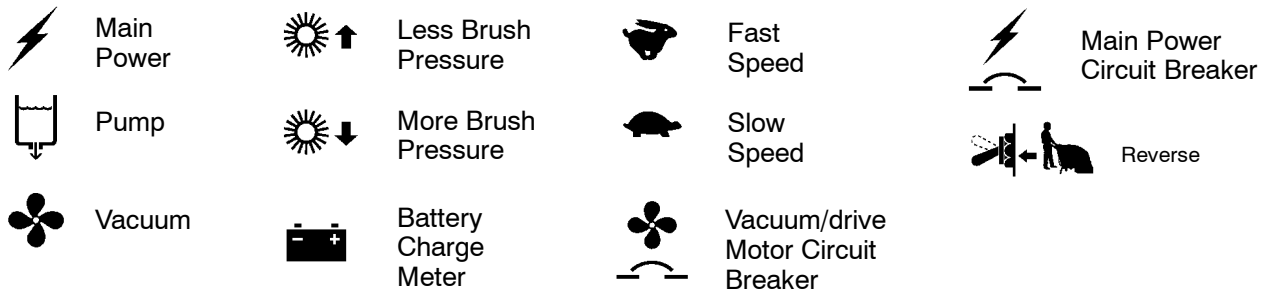

MACHINE INSTALLATION

UNCRATING MACHINE

1. Carefully check the shipping crate for signs of damage. Report damages at once to carrier.
2. Check the contents list. Contact distributor for missing items.

Contents:

- 1 - Battery Tray #601991
- 2 - Batteries, 225 Ah 12V #1070591 (included with machine PAC)
- 1 - Battery Cable #6 x 15" Black #130364
- 4 - Battery Post Caps #45962
- 4 - Black Battery Boots #611221
- 1 - Battery Charger 24VDC/19A #1029256 (included with machine PAC)

Batteries and charger are packaged separately.

3. To uncrate your machine, remove the shipping hardware and straps that secure the machine to the pallet. With assistance, carefully lift the machine off the pallet.

ATTENTION: Do not roll machine off pallet unless a ramp is used, machine damage may occur.

ATTENTION: To prevent possible machine damage, install batteries after removing machine from shipping pallet.

INSTALLING BATTERIES

⚠ WARNING: Fire Or Explosion Hazard. Batteries Emit Hydrogen Gas. Keep Sparks And Open Flame Away. Keep Battery Hood Open When Charging.

FOR SAFETY: When servicing machine, wear protective gloves and eye protection when handling batteries and battery cables. Avoid contact with battery acid.

Battery Specifications:

Two 12 volt, deep cycle batteries. Consult with an Authorized Distributor for specific batteries. Maximum battery dimensions are 178 mm (7 in) W x 381 mm (15 in) L x 356 mm (14 in) H.

1. Turn all switches to the OFF position.
2. Carefully hinge open recovery tank to access battery compartment. Remove loose battery cable from compartment (Figure 1).



FIG. 1

3. Carefully install batteries into battery tray at bottom of compartment and arrange battery posts as shown (Figure 2).

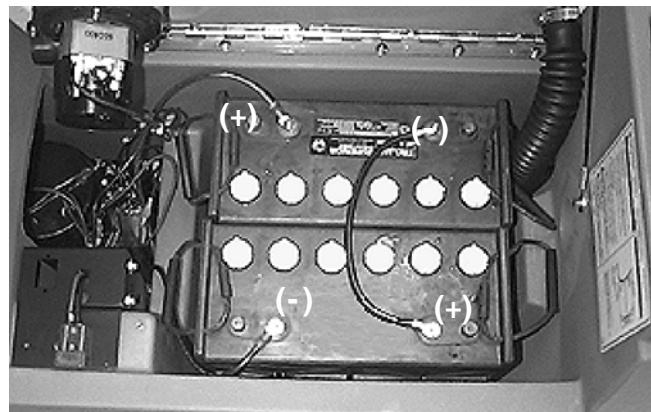

FIG. 2

ATTENTION: Do not drop batteries into compartment, battery and machine housing damage may result. This damage is not covered by warranty.

4. Before connecting battery cables, make sure terminals and posts are clean. Use a post cleaner and wire brush to clean posts and terminals.
5. Connect battery cables to battery posts as shown (RED TO POSITIVE & BLACK TO NEGATIVE) (Figure 2).

NOTE: Apply a light coating of non-metallic grease or protective spray on the cable connections to prevent battery corrosion.

OPERATION

- After batteries are properly installed, turn on the main switch and check battery meter charge level to ensure batteries are fully charged. Charge if necessary, See Battery Charging (Figure 3).

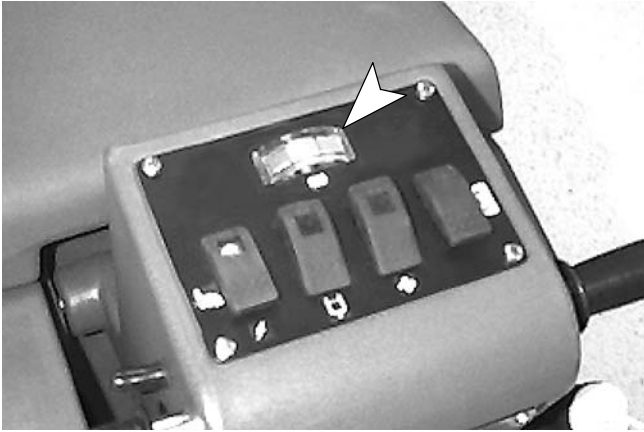

FIG. 3

MACHINE SETUP

FILLING SOLUTION TANK

- Transport machine to filling station. Raise brush/pick-up head when transporting.
- Turn off main switch.

FOR SAFETY: Before leaving or servicing machine, stop on level surface, turn off machine.

- Open solution fill door at front of machine and fill solution tank with 64 L (17 gal) of clean water, 60°C (140°F) maximum temperature. Or you can use the rear fill port to fill solution tank. Twist off plug and insert hose to fill. The clear tube below the fill port has 19 L (5 gal) increment markers to indicate amount of water in tank (Figure 4).

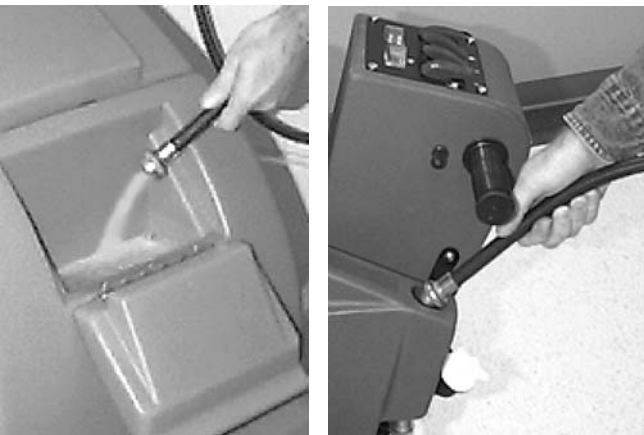

FIG. 4

NOTE: The water must **not** be hotter than 60°C (140°F) or tank damage may occur.

NOTE: When filling the solution tank with a bucket, make sure that the bucket is clean. Do not use the same bucket for filling and draining the machine.

⚠ WARNING: Fire or Explosion Hazard. Never Use Flammable Liquids.

- Add cleaning chemical. See proper dilution ratio instructions on bottle.

FOR SAFETY: When using machine, follow mixing and handling instructions on chemical containers.

ATTENTION: Use only recommended detergents. Machine damage due to improper detergent usage will void the manufacturer's warranty. Contact your Tennant Sales Representative for detergent recommendations.

ADJUSTING CONTROL GRIP HEIGHT

The machine has three control grip height settings.

- Locate two spring loaded levers below console.
- Squeeze levers together and lift or lower control grips to a comfortable operating height (Figure 5).

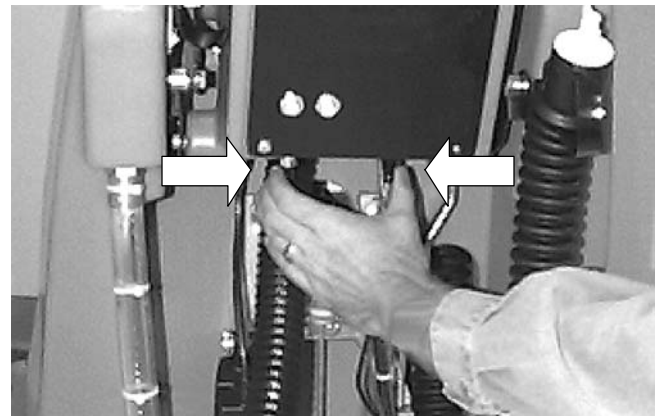

FIG. 5

MACHINE OPERATION

FOR SAFETY: Do not operate machine, unless operation manual is read and understood.

⚠ WARNING: Fire Or Explosion Hazard. Never Operate Machine In Or Near Flammable Liquids, Vapors Or Combustible Dusts.

PRE- OPERATION CHECKS

- Vacuum floor and remove any debris.
- Check battery meter charge level to ensure batteries are fully charged (See BATTERY CHARGING).
- Check that spray bar is installed.
- Check that inline strainer filter is installed.
- Inspect spray tips for proper spray pattern (See DAILY MAINTENANCE).

1. Turn on main switch.
2. Lower brush/pick-up head to floor by depressing brush height switch (Figure 6).

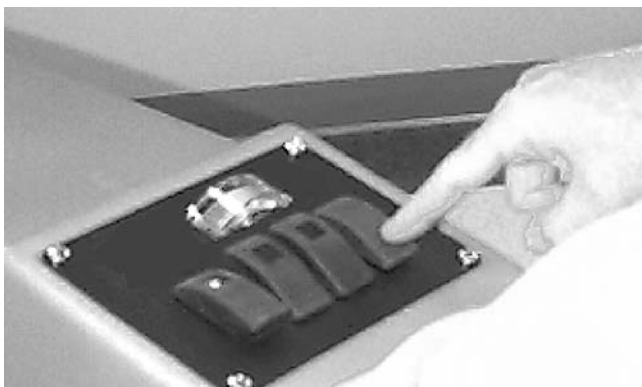

FIG. 6

3. Turn on vacuum and pump switches.

NOTE: *The brush and pump will start once control grips are rotated.*

4. Before you begin cleaning, turn speed control knob to slowest speed (Figure 7).



FIG. 7

5. To begin cleaning, rotate control grips completely forward and gradually turn speed control knob to desired cleaning speed (Figure 7).

For optimum cleaning results, operate at a cleaning speed of 15 m (50 ft) per minute for deep cleaning and 30 m (100 ft) per minute for interim cleaning.

⚠ WARNING: Fire Or Explosion Hazard. Do Not Pick Up Flammable Materials Or Reactive Metals.

6. To stop machine, release control grips.
7. To operate machine in reverse, simply pull reverse switch backwards one speed (Figure 8).



FIG. 8

8. After cleaning carpets, allow sufficient time for carpet to dry. Use a carpet blower to reduce drying time.

OPERATION

WHILE OPERATING MACHINE

⚠ WARNING: Fire Or Explosion Hazard. Do Not Pick Up Flammable Materials Or Reactive Metals.

1. Periodically check for foam buildup in recovery tank (*look through clear lid*). If excessive foam buildup begins to develop, pour a recommended foam control solution into recovery tank.

ATTENTION: Do not allow foam to enter the float shut-off screen, vacuum motor damage will result. Foam will not activate the float shut-off screen.

2. Always operate at a slower speed when cleaning around walls or obstacles.
3. Always reduce speed to maintain control when turning machine.
4. Overlap each pass by 50 mm (2 in).
5. Before reaching end of cleaning path, turn off pump switch and continue to drive machine forward to extract solution.
6. Periodically check battery meter discharge level. When needle drops to the red zone, recharge batteries.

ATTENTION: Do not continue to run machine when battery meter needle is in the red zone, battery damage will result.

7. While cleaning, view clear hose gallon marker for remaining cleaning solution. Each mark on hose indicates 19 L (5 gal).
8. When solution tank runs dry, turn off pump and vacuum switches, raise brush, and transport machine to draining area (See DRAINING TANKS).
9. If the cleaning path leaves streaks, spray tip cleaning is required (See MONTHLY MAINTENANCE).

CIRCUIT BREAKERS

The machine is equipped with two resettable circuit breakers, Main (15A) and Vacuum/Drive (60A), to protect machine from damage. If a circuit breaker should trip during operation, determine the cause, allow motor to cool and then manually reset the breaker button. The circuit breaker panel is located at rear of machine (Figure 9).

The vacuum/drive circuit breaker (60A) is designed to stop current flow by manually pulling out the circuit breaker button. This allows you to keep the machine stationary while performing specific maintenance procedures.

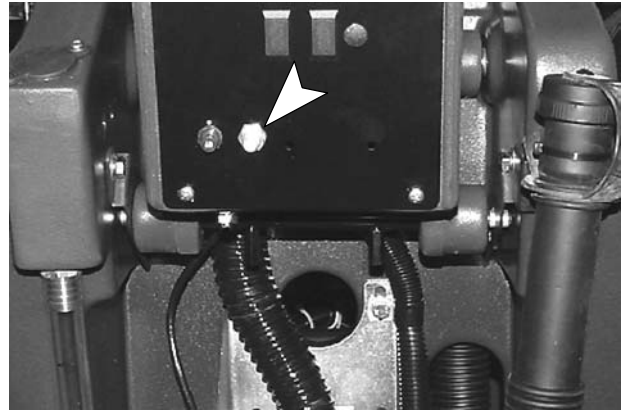

FIG. 9

Contact an Authorized Service Center for machine repairs.

FOR SAFETY: When servicing machine, all repairs must be performed by a qualified service person.

OPTIONAL ACCESSORY TOOL SETUP AND OPERATION

Machine is equipped with accessory tool connections. Accessory tool enables you to reach areas that the machine is unable, such as alcoves, stairs and corners (See Options).

1. Vacuum area before cleaning.
2. Fill solution tank and add cleaning chemical (See FILLING SOLUTION TANK).

⚠ WARNING: Fire or Explosion Hazard. Never Use Flammable Liquids.

3. Disconnect lower vacuum hose at rear of machine and replace with accessory vacuum hose (Figure 10).



FIG. 10

- Connect solution hose to accessory tool coupler, located at lower rear of machine (Figure 11).



FIG. 11

- Connect accessory tool to solution hose and vacuum hose (Figure 12).

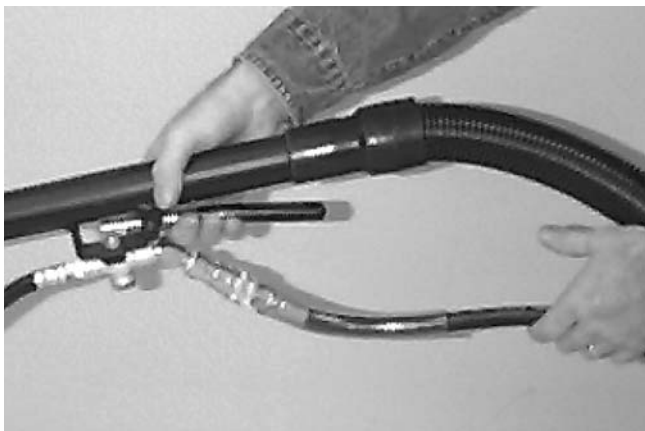

FIG. 12

- Turn on main, pump and vacuum switches.
- Take accessory tool and begin cleaning at top of area and work backwards toward machine.

⚠ WARNING: Fire Or Explosion Hazard. Do Not Pick Up Flammable Materials Or Reactive Metals.

- Place accessory tool head on area to be cleaned; squeeze trigger, apply downward pressure on accessory tool head, and slowly pull tool backwards. Release trigger 152 mm (6 in) from end of stroke (Figure 13).



FIG. 13

- When returning for next stroke, push accessory tool forward over same path with trigger released. Continue this pull and push method with a 50 to 102 mm (2 to 4 in) overlap of each stroke.

NOTE: For heavily soiled areas, repeat stroke or change angle of stroke.

- Empty recovery tank when solution tank runs dry (See DRAINING TANKS).

ATTENTION: Do not allow foam to enter the float shut-off screen, vacuum motor damage will result. Foam will not activate the float shut-off screen.

DRAINING TANKS

The recovery tank should be drained and cleaned out after every use. The solution tank should be cleaned out periodically to remove any corrosion.

Transport the machine to a draining site, turn machine off and follow the draining instructions below:

ATTENTION: Raise brush/pick-up head when transporting machine to floor drain.

FOR SAFETY: Before leaving or servicing machine, stop on level surface, turn off machine.

OPERATION

DRAINING RECOVERY TANK

Always empty recovery tank when refilling solution tank. You may refill solution tank while emptying recovery tank. To drain recovery tank, perform the following steps:

ATTENTION: If recovery tank is not emptied between fill-ups, foam or water will enter vacuum standpipe and damage vacuum motor. Float shut-off screen will not keep foam out of standpipe. Vacuum damage due to foam or water is not covered by warranty.

1. Remove drain hose from holder, position hose over floor drain and twist off drain hose cap. To completely drain recovery tank, hinge open tank and flip up tank support stand to rest tank on (Figure 14).

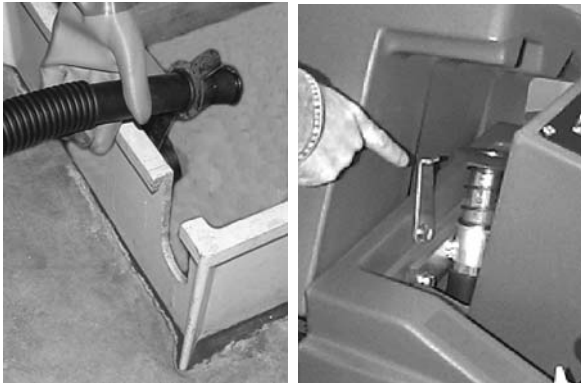

FIG. 14

2. Rinse out recovery tank after each use. This will prevent a foul odor and residue buildup in tank. Unscrew clear lid on recovery tank and rinse out the tank with hose. Be careful not to spray water into float shut-off screen.

NOTE: The water must **not** be hotter than 60° C (140° F) or tank damage may occur. Do not use steam to clean tank.

NOTE: When filling the solution tank with a bucket, make sure that the bucket is clean. Do not use the same bucket for filling and draining the machine.

3. Replace drain hose plug tightly when tank is empty.

DRAINING SOLUTION TANK

To drain leftover cleaning solution from solution tank, follow steps below:

1. Pull clear hose off hose barb at rear of machine and drain solution into floor drain or bucket (Figure 15).



FIG. 15

2. Rinse out solution tank and solution system with clean water after each use. This will prevent clogging due to chemical buildup. Use clear hose to drain solution tank when rinsing.

NOTE: The water must **not** be hotter than 60° C (140° F) or tank damage may occur. Do not use steam to clean tank.

NOTE: When filling the solution tank with a bucket, make sure that the bucket is clean. Do not use the same bucket for filling and draining the machine.

3. When reconnecting clear hose to hose barb, be certain hose is completely pushed onto hose barb.

BATTERY CHARGING

ATTENTION: To prolong the life of the batteries and to provide optimum machine performance, ONLY recharge the batteries after a total of 30 minutes of use or more. Do not leave batteries discharged for lengthy periods.

The following charging instructions are intended for battery chargers supplied with the machine. Only use a battery charger with the following specifications to prevent battery damage.

BATTERY CHARGER SPECIFICATIONS:

- CHARGER TYPE:
 - FOR LEAD ACID BATTERIES
- OUTPUT VOLTAGE - 24 VOLTS
- OUTPUT CURRENT - 25 AMPS MAXIMUM
- AUTOMATIC SHUTOFF CIRCUIT
- FOR DEEP CYCLE BATTERY CHARGING

⚠ WARNING: Fire Or Explosion Hazard. Batteries Emit Hydrogen Gas. Keep Sparks And Open Flame Away. Keep Battery Hood Open When Charging.

1. Transport machine to a well ventilated area for charging.
2. Lead acid batteries: Before charging the batteries, check the electrolyte level in each battery cell (Figure 16).



FIG. 16

FOR SAFETY: When servicing machine, wear protective gloves and eye protection when handling batteries and battery cables. Avoid contact with battery acid.

The electrolyte level (A) should slightly cover the battery plates (B). Add distilled water as needed. DO NOT OVERFILL, the fluid may expand and overflow while charging. Replace cell caps before charging (Figure 17).

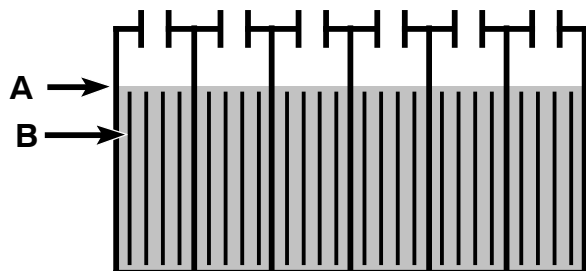
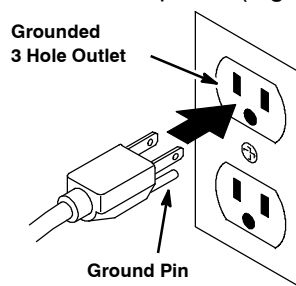

FIG. 17

3. Connect the charger's AC power supply cord to a properly grounded receptacle (Figure 18).



(120V)

FIG. 18

5. Plug charger's DC output connector to battery connector located near battery compartment. Rest the recovery tank on the support stand to promote ventilation during charging (Figure 19).



FIG. 19

FOR SAFETY: Do not operate charger unless cord is properly grounded.

6. The charger will automatically begin charging and shut off when fully charged.

NOTE: The machine will not operate once the battery charger is connected.

ATTENTION: Do not disconnect the charger's DC cord from the machine's receptacle when the charger is operating. Arcing may result. If the charger must be interrupted during charging, disconnect the AC power supply cord first.

⚠ WARNING: Fire Or Explosion Hazard. Batteries Emit Hydrogen Gas. Keep Sparks And Open Flame Away. Keep Battery Compartment Open When Charging.

OPERATION

9. After charging, check the electrolyte level (A) again. The level should be approximately 1 cm from the bottom of the fill- port (B) (Figure 20). Add distilled water if needed. **DO NOT OVERFILL.**

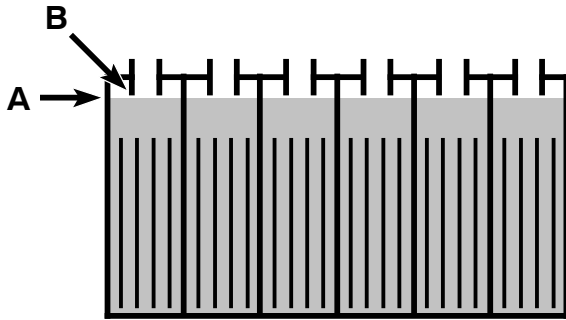

FIG. 20

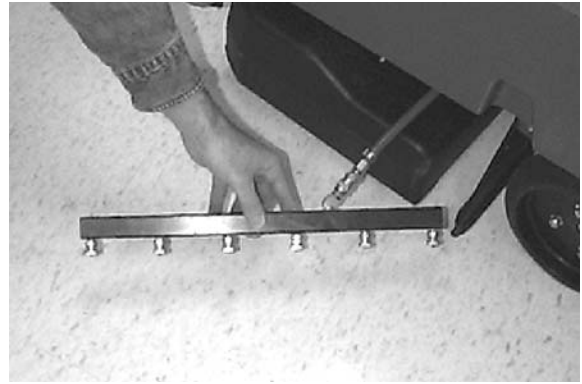

FIG. 21

2. Drain and clean out the recovery tank.
3. Remove and clean the float shut-off screen located in the recovery tank (Figure 22).



FIG. 22

4. Drain the solution tank and rinse out the inside with hot water, 60°C (140°F) maximum temperature, as needed.
5. Clean the machine with an all purpose cleaner and damp cloth.

FOR SAFETY: When cleaning machine, do not power spray or hose off machine. Electrical malfunction may occur.

6. Remove inline strainer filter and rinse out. Make sure solution tank is empty before removing filter. Filter is located under machine at rear (Figure 23).

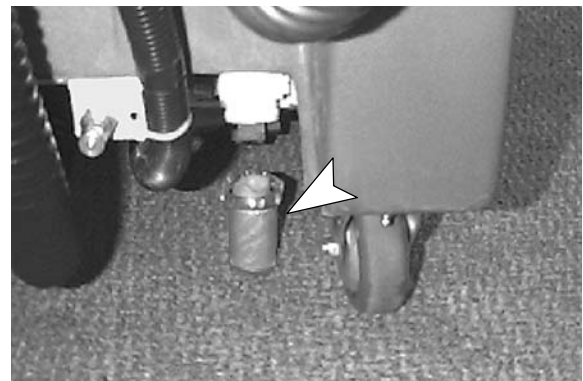

FIG. 23

MACHINE MAINTENANCE

To keep machine in good working condition, simply follow daily, monthly and quarterly maintenance procedures.

FOR SAFETY: Before leaving or servicing machine, stop on level surface, turn off machine.

⚠ WARNING: Electrical Hazard. Disconnect Battery Cables Before Servicing Machine.

ATTENTION: Contact an Authorized Service Center for machine repairs. Machine repairs performed by other than an authorized person will void your warranty.

DAILY MAINTENANCE (After Every Use)

1. Inspect spray tips for proper spray pattern:
 - a. Pull out vacuum/drive circuit breaker button, located at rear of control console.
 - b. Lower brush/pick-up head and remove detachable spray bar from brush base. Do not disconnect bar from quick coupler. Raise brush after removing spray bar (Figure 21).
 - c. Turn on main and pump switches.
 - d. Rotate control grips and observe spray pattern. Pattern should fan out evenly across the width of the spray bar.
 - e. Clean or replace defective twist-out spray tips if necessary (See MONTHLY MAINTENANCE).

7. Inspect brush for entangled debris.
8. Recharge the batteries after a total of 30 minutes of use or more (Figure 24).

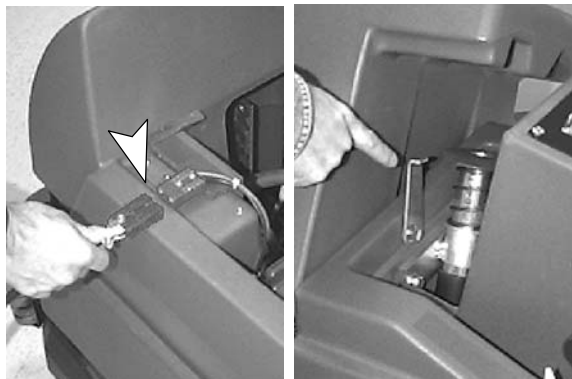

FIG. 24

MONTHLY MAINTENANCE (Every 80 hours of use)

1. Clean the battery tops to prevent corrosion (See BATTERY MAINTENANCE).
2. Check for loose battery cable connections.
3. Flush out tanks and solution lines:
 - a. Pull out the vacuum/drive circuit breaker button, located at rear of control console.
 - b. Pour 750 ml (24 oz) of an acetic acid solution with 11.3 L (3 gal) of hot water into solution tank; do not exceed 60°C (140°F).

FOR SAFETY: When using machine, follow mixing and handling instructions on chemical containers.

- c. Turn on the main and pump switches.
- d. Over a floor drain, rotate control grips and hold for one to two minutes.
- e. Shut off power and let machine set overnight to allow acetic acid solution to breakdown alkaline buildup.
- f. Next day, operate pump to disperse remaining acetic acid solution.
- g. Then rinse out solution tank and solution lines with clean water.
- h. Reset drive circuit breaker button when completed.

4. Remove detachable spray bar from brush base. Remove twist-out spray tips from spray bar and soak in 118 ml (4 oz) acetic acid solution for up to 6 hours. After soaking tips, use a small brush to remove excess alkaline and rinse thoroughly. **DO NOT** use pointed objects to unplug spray tips (Figure 25).



FIG. 25

5. Lubricate caster grease fittings with a water resistant grease.
6. Lubricate all linkage pivot points with silicone spray, then coat with a water resistant grease to maintain a smooth operation.
7. Check the machine for loose nuts and bolts.
8. Check the machine for leaks.

QUARTERLY MAINTENANCE

Every 250 hours, check the drive transaxle motor, the vacuum motor and the brush motor for carbon brush wear. Replace carbon brushes when worn to a length of 10 mm (.375 in) or less.

Contact an Authorized Service Center for machine repairs.

FOR SAFETY: When servicing machine, all repairs must be performed by a qualified service person.

⚠ WARNING: Electrical Hazard. Disconnect Battery Cables Before Servicing Machine.

OPERATION

BATTERY MAINTENANCE

⚠ WARNING: Fire Or Explosion Hazard. Batteries Emit Hydrogen Gas. Keep Sparks And Open Flame Away. Keep Battery Compartment Open When Charging.

FOR SAFETY: When servicing machine, wear protective gloves and eye protection when handling batteries and battery cables. Avoid contact with battery acid.

1. Always follow proper charging instructions (See CHARGING BATTERIES).
2. Check the electrolyte level (A) in each battery cell **after charging batteries**. The level should be approximately 1 cm from the bottom of the fill-port (B). Add distilled water if needed (Figure 26) **DO NOT OVERFILL.**

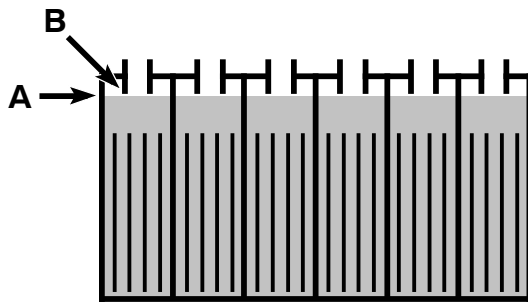

FIG. 26

3. Measuring the specific gravity using a hydrometer is a way to determine the charge level, and condition of the batteries (Figure 27). If one or more of the battery cells test lower than the other battery cells (0.050 or more), the cell is damaged, shorted, or is about to fail.



FIG. 27

NOTE: Do not take readings immediately after adding distilled water. If the water and acid are not thoroughly mixed, the readings may not be accurate. Check the hydrometer readings against the following chart to determine the remaining battery charge level:

SPECIFIC GRAVITY at 27° C	BATTERY CHARGE
1.265	100% CHARGED
1.223	75% CHARGED
1.185	50% CHARGED
1.148	25% CHARGED
1.110	DISCHARGED

NOTE: If the readings are taken when the battery electrolyte is any temperature other than 27° C, the reading must be temperature corrected. Add or subtract to the specific gravity reading 0.004, 4 points, for each 6° C above or below 27° C.

4. Keep battery tops and terminals clean and dry.
To clean batteries:
 - a. Mix a strong solution of baking soda and water (Figure 28).



FIG. 28

- b. Brush solution sparingly over battery tops, terminal and cable connectors.

NOTE: Do not allow baking soda solution to enter battery cells.

- c. Use wire brush to clean terminal post and cable connections.
 - d. After cleaning, apply a coating of clear battery post protectant to terminals and cable connections.
5. Check for loose or worn cables. Replace if worn.

TRANSPORTING MACHINE

When transporting the machine by use of trailer or truck, be certain to follow the tie-down procedures below:

FOR SAFETY: When using machine, go slow on inclines and slippery surfaces.

1. Raise the brush/pick-up head.
2. Load the machine using a recommended loading ramp.
3. Position the front of machine up against the front of the trailer or truck. Once the machine is positioned, lower the brush/pick-up head.
4. Place a block behind each wheel to prevent the machine from rolling.
5. Place tie-down straps over the top of machine to prevent it from tipping. It may be necessary to install tie-down brackets to the floor of your trailer or truck.

NOTE: Do not use control grips to secure machine for transporting.

FOR SAFETY: When transporting machine, use a recommended ramp when loading/unloading on/off truck or trailer, use tie-down straps to secure machine to truck or trailer.

STORING MACHINE

1. Charge the batteries before storing. Never store the machine with discharged batteries.
2. Drain and rinse the tanks thoroughly.
3. Store the machine in a dry area with brush base in the up position.
4. Open the recovery tank lid to promote air circulation.
5. If storing machine in freezing temperatures, make sure to drain machine of all water.

ATTENTION: Do not allow machine to freeze without anti freeze. Damage due to freezing temperatures is not covered by warranty.

ATTENTION: Do not expose machine to rain and store indoors.

RECOMMENDED STOCK ITEMS

Refer to the Parts List section in this manual for recommended stock items. Stock Items are clearly identified with a bullet preceding the parts description. See example below:



Ref.	Part No.	Description	Qty.
1	701103	ASM.,STANDPIPE	1
2	180618	●FLOAT, SHUTOFF	1
3	230197	NIPPLE	1
4	101714	●GASKET	1
5	210240	NUT, FLANGED	1

OPERATION

TROUBLE SHOOTING

PROBLEM	CAUSE	SOLUTION
No power.	Faulty main switch.	Contact Service Center.
	Batteries need charging.	See Charging Batteries.
	Main circuit breaker is pulled out.	Depress main circuit breaker.
	Faulty battery(s).	Replace battery(s).
	Loose battery cable.	Tighten loose cable.
	MAIN circuit breaker has tripped.	Determine cause and reset circuit breaker button.
Brush motor does not operate.	Pump switch is not on.	Turn on pump switch.
	Control grips are not rotated.	Rotate control grips.
	Brush circuit breaker has tripped or is pulled out.	Remove obstruction from brush and reset brush circuit breaker button.
	Faulty brush motor or wiring.	Contact Service Center.
	Carbon brushes worn.	Contact Service Center.
	Loose or broken belt.	Replace, or contact Service Center.
Vacuum motor does not operate.	Faulty vacuum switch.	Contact Service Center.
	Vacuum motor thermal overload activated.	Remove obstruction and wait 20 minutes for motor to cool.
	Faulty vacuum motor or wiring.	Contact Service Center.
	Carbon brushes worn.	Contact Service Center.
Drive motor does not operate.	Drive motor circuit breaker has tripped.	Determine cause and reset breaker.
	Faulty speed control board or connection.	Contact Service Center.
	Faulty solenoid.	Contact Service Center.
	Faulty drive motor.	Contact Service Center.
	Faulty wiring.	Contact Service Center.
	Worn carbon brushes.	Contact Service Center.
Drive motor operates, but not correctly.	Faulty potentiometer or speed control board.	Contact Service Center.
	Loose wire connection.	Contact Service Center.
Uneven or no solution spray.	Twist-out spray tips are plugged.	Remove and clean.
	Control grips are not rotated.	Rotate control grips.
	Solution line or solution tank filter is clogged.	Remove hose and blow compressed air through it. Flush solution tank after each use.
	Inline strainer filter is plugged.	Drain solution tank, remove filter and clean. Located under machine at rear.
	Faulty pump switch.	Contact Service Center.
	Faulty pump or solenoid.	Contact Service Center.
Short run time.	Batteries not fully charged.	Charge batteries.
	Bad cell in one or more batteries.	Replace battery.
	Batteries need maintenance.	See Battery Maintenance.
	Faulty charger.	Replace battery charger.

TROUBLE SHOOTING - Continued

PROBLEM	CAUSE	SOLUTION
Poor vacuum recovery.	Recovery tank is full.	Empty recovery tank.
	Float shut-off screen inside recovery tank is clogged.	Remove screen and clean.
	Pick-up head is clogged with debris.	Remove debris, use coat hanger.
	Pick-up head is not sealed to carpet.	Adjust pick-up head.
	Faulty actuator.	Contact Service Center.
	Vacuum hose connections are loose or hose has a hole.	Push hose cuffs firmly on connections. Replace hose if damaged.
	Vacuum hose is clogged with debris.	Remove clogged debris.
	Recovery tank inlet hole is obstructed.	Empty recovery tank and tilt tank sideways to access inlet hole, remove obstruction.
	Tank gasket is defective.	Replace gasket.
	Drain hose plug is loose.	Tighten drain plug.
	Recovery tank lid is loose.	Tighten lid.
	Vacuum motor is loose.	Contact Service Center.
	Battery charge level is low.	Charge batteries. Do not run machine when battery meter is in the red zone.

OPERATION

SPECIFICATIONS

MODEL	Falcon™ Ultra B
LENGTH	1372 mm (54 in)
WIDTH	762 mm (30 in)
HEIGHT	1067 mm (42 in)
WEIGHT	170 kg (375 lbs) - w/ batteries 272 kg (600 lbs)
SOL./REC TANK CAPACITY	64 L (17 gal)
SPEED CONTROL	Variable Fwd. / Fixed Reverse
CLEANING SPEED (MAX)	418.05m ² (4,500 sq. ft) per hour
CLEANING PATH WIDTH	559 mm (22 in)
PAD PRESSURE	Variable 36- 68Kg (80- 150 lbs)
SOLUTION PUMP	6.9 bar (100 psi) max., 24V
DRIVE SYSTEM	Transaxle, .2 h.p., 24V
BRUSH MOTOR	.2 h.p., 2000 rpm, 24V, 8A, 192W
VACUUM MOTOR	1 h.p., 2- stage 7.2", 24V, 30A, 720W
WATERLIFT	2057 mm (81 in)
BATTERIES	2- 12V, 225AH
RUN TIME PER CHARGE	Up to 4.5 hours
DECIBEL RATING AT OPERATOR'S EAR, INDOORS ON CARPET	75dB(A)

MACHINE DIMENSIONS

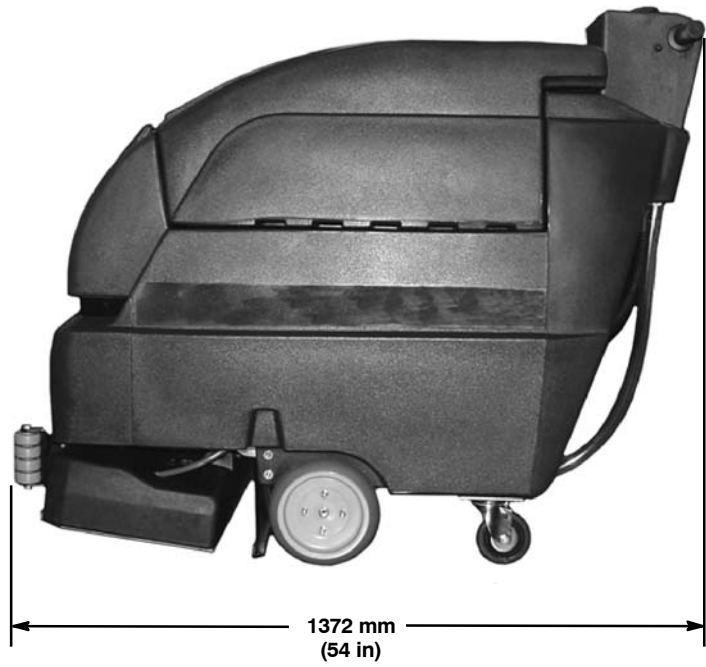

ELECTRICAL DIAGRAM

WIRE DIAGRAM

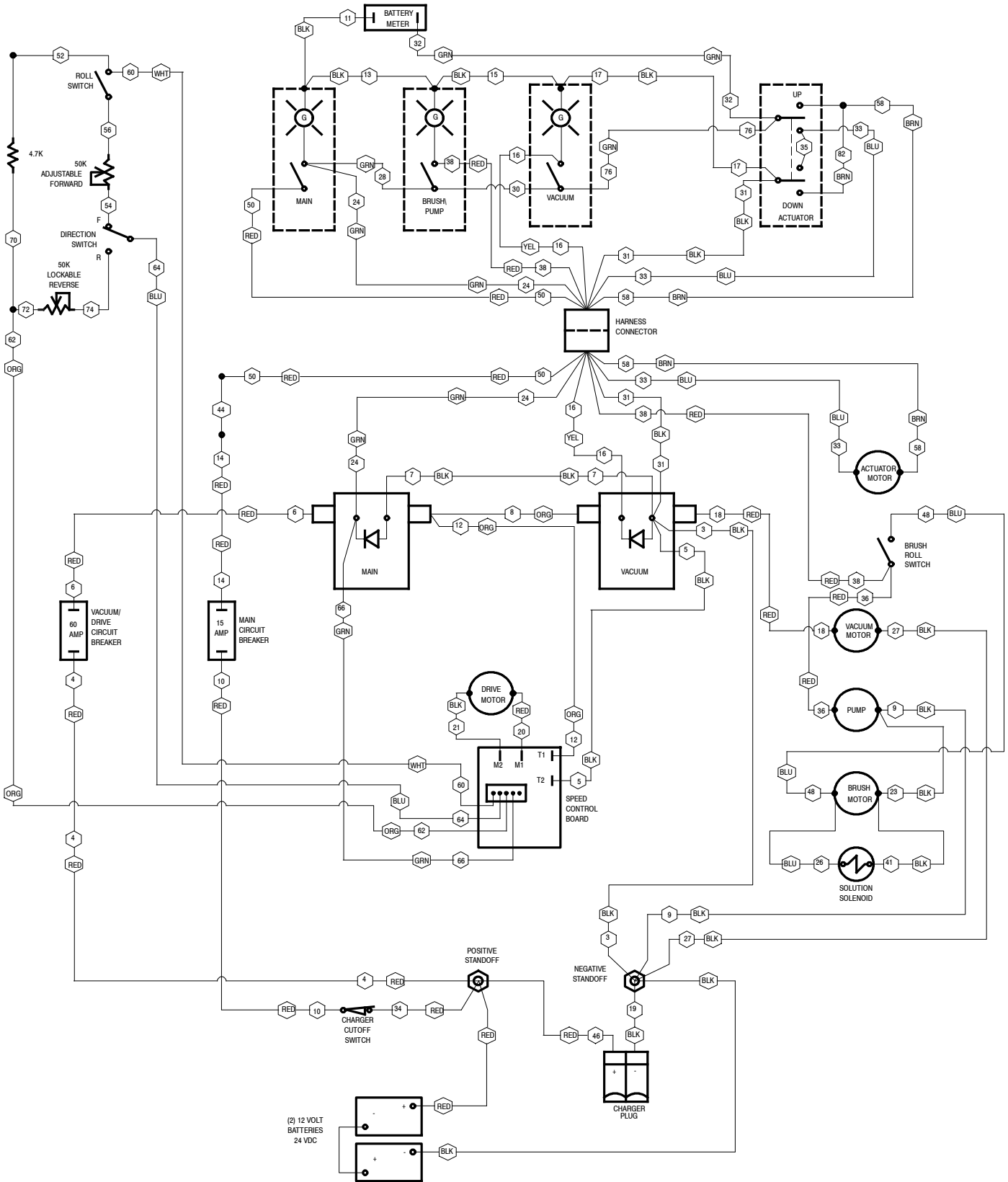

LADDER DIAGRAM

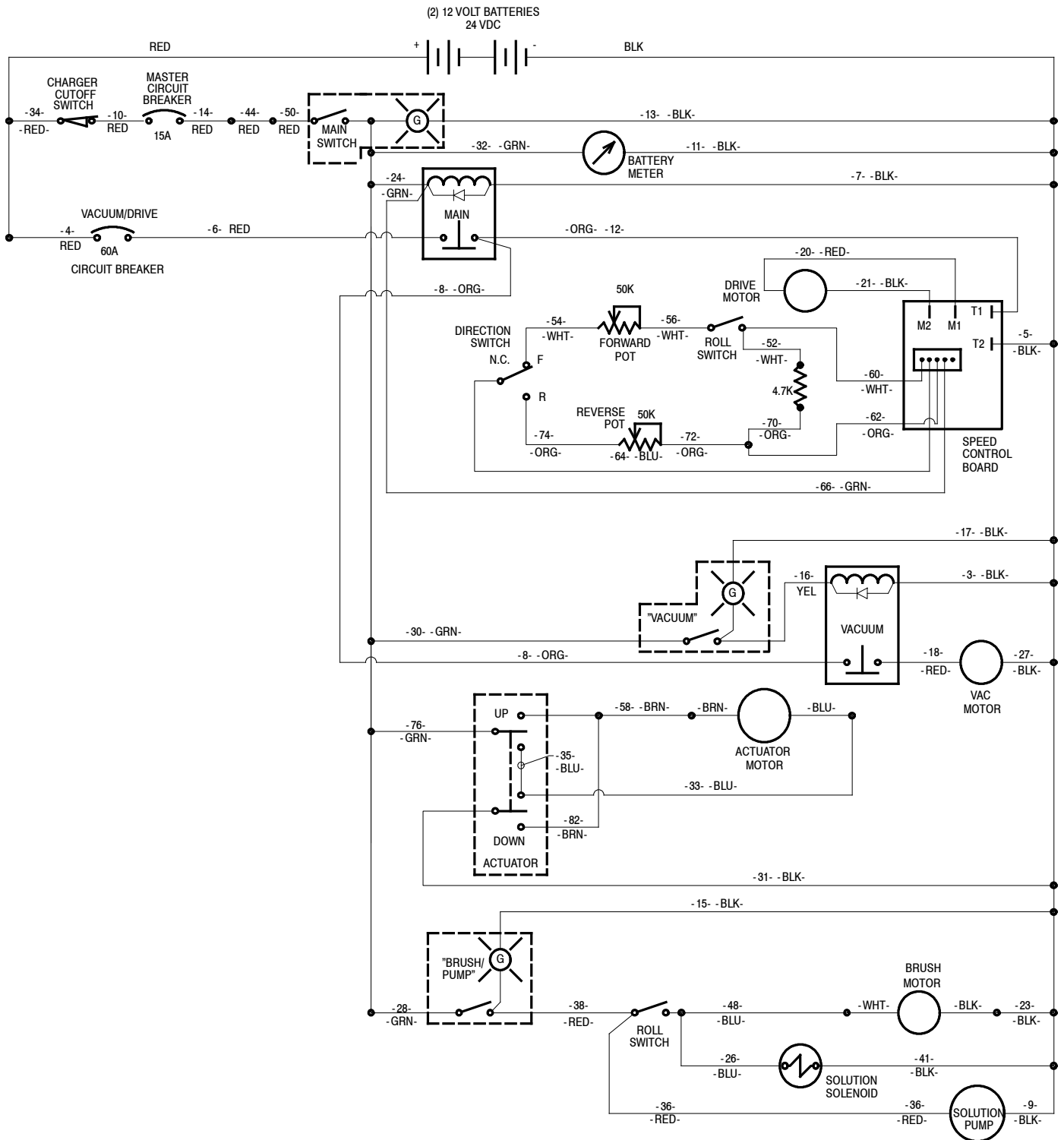

PARTS LIST

SOLUTION TANK GROUP

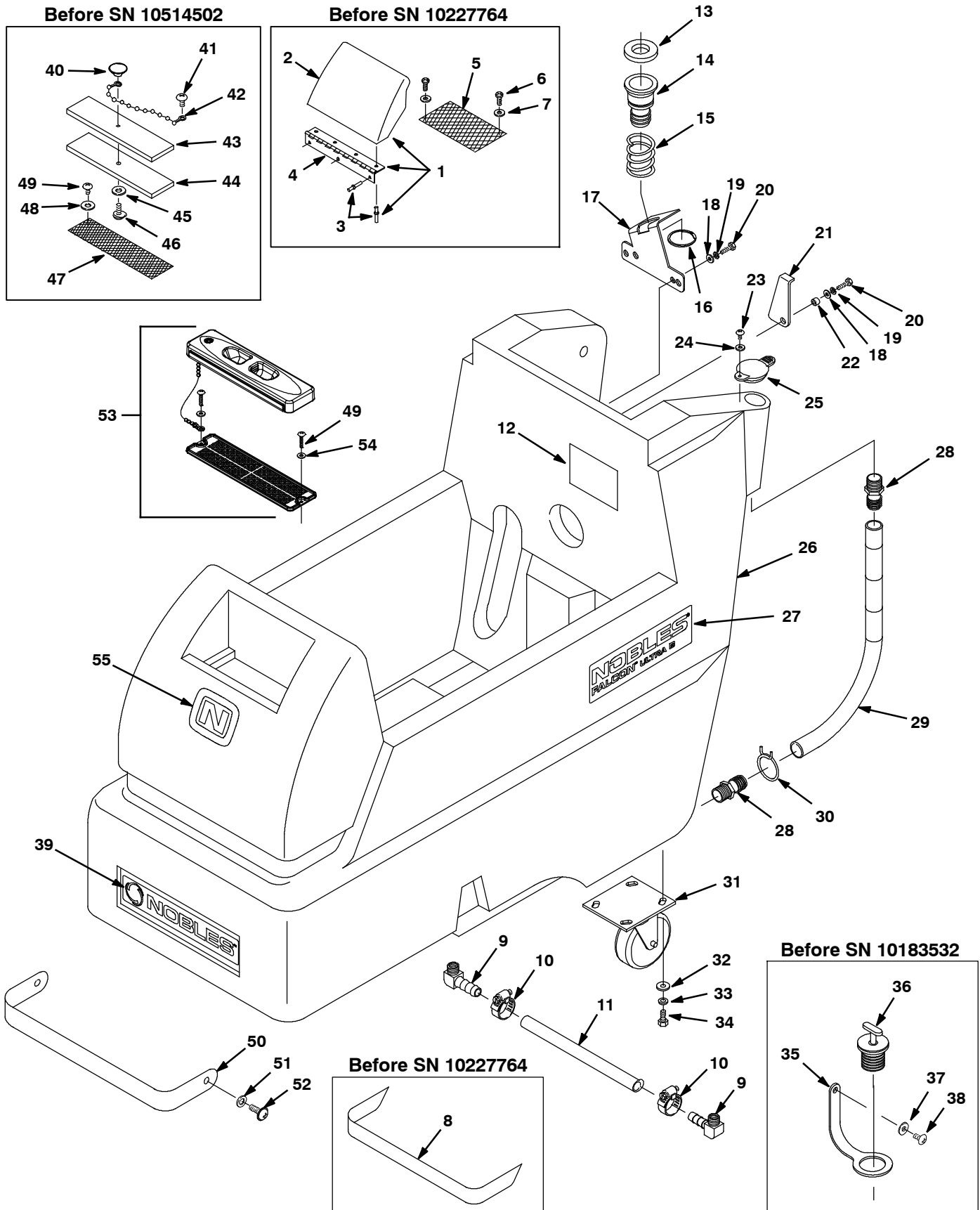

SOLUTION TANK GROUP

REF	PART #	DESCRIPTION	QTY.
∇ 1	608518	ASM., SOL. TANK COVER GREEN (Before SN 10227764)	1
▲ 2	612518	COVER, TANK, GREEN (Before SN 10227764)	1
▲ 3	611068	HINGE, COVER (Before SN 10227764)	1
▲ 4	140706	RIVET, POP (Before SN 10227764)	7
5	602529	SCREEN, FILL (Before SN 10227764)	1
6	3701.6	SCREW, #6X3/8 (Before SN 10227764)	2
7	140032	WASHER, FLAT (Before SN 10227764)	2
8	600730	DECAL, RECESS (Before SN 10227764) (NO LONGER AVAILABLE)	1
9	150419	ELBOW, 1/4M X 3/8H 90°	2
10	140310	CLAMP	2
11	607310	HOSE, 3/8" X 17.5"	1
12	603233	DECAL, BATTERY DIAGRAM	1
13	630010	●GASKET	1
14	630011	TUBE, ADAPTER	1
15	630267	SPRING, COMP	1
16	630016	RING, RETAINING	1
17	608706	BRACKET, VAC TUBE	1
18	140027	WASHER, FLAT	3
19	140015	WASHER, LOCK	3
20	16931	SCREW, HEX, M8 X 1.25 X 20, 8.8	3
21	230925	SUPPORT, RECOVERY TANK	1
22	611418	SLEEVE	1
23	1018155	SCREW, PAN, M4.8 X 16, SS, TCUT	1
24	01683	WASHER, FLAT, #10 SS	1
25	1012965	●CAP, PORT, SOLUTION FILL	1
26	1023348	TANK, SOLUTION, GREEN	1
	1023712	KIT, TANK, SOLUTION, GREEN (Before SN 10227764)	1
27	608417	LABEL [FALCON ULTRA NOBLES] (NO LONGER AVAILABLE)	2
	1035597	LABEL, MODEL [NOBLES FALCON ULTRA B]	2
28	150529	FITTING, 3/4 HOSE BARB	2
29	607983	HOSE, W/LEVEL INDICATORS	1
30	608915	CLAMP, HOSE 2 WIRE	1
31	1029695	CASTER, SWIVEL, 4.0D 1.4W, 4- HOLE [400LB]	2

∇ ASSEMBLY

▲ INCLUDED IN ASSEMBLY

● RECOMMENDED STOCK ITEMS

REF	PART #	DESCRIPTION	QTY.
32	140027	WASHER, FLAT, 0.35B 0.75D .04 SS	8
33	140015	WASHER, LOCK, SPLT, 0.31 SS	8
34	09740	SCREW, HEX, M8 X 1.25 X 20, SS	8
35	600476	STRAP, PLUG (Before SN 10183532)	1
36	621324	●PLUG, EXPANSION (Before SN 10183532)	1
37	140011	WASHER, FLAT (Before SN 10183532)	1
38	140350	SCREW, #10X1/2 (Before SN 10183532)	1
39	608184	LABEL, LOGO, 09.3L 2COLOR (NO LONGER AVAILABLE)	1
40	578301	●KNOB, RND (Before SN 10514502)	1
41	140826	SCREW, PAN, #6- 32X0.75, PHL SS (Before SN 10514502)	1
42	621443	●CHAIN, BALL, #10X157L, SS (Before SN 10514502)	1
43	605061	●COVER, SOLUTION FILL (Before SN 10514502) (REPLACED BY 1060173)	1
44	605062	●GASKET, COVER, SOLUTION FILL (Before SN 10514502) (REPLACED BY 1060173)	1
45	07514	WASHER, LOCK, INT, #10 SS (Before SN 10514502)	1
46	578201000	SCREW, PAN, #10- 32X0.50, PHL (Before SN 10514502)	1
47	606146	●FILTER, SCREEN, SOL- FILL (Before SN 10514502) (REPLACED BY 1060173)	1
48	140032	WASHER, #6 FLAT SS	2
49	140826	SCREW, PAN, #6- 32X0.75, PHL SS	2
50	1020193	SHIELD, LIGHT	1
51	140032	WASHER, FLAT, #6 SS	2
52	140826	SCREW, PAN, #06- 32 X 0.75, SS PHL SHTMTL	2
53	1060173	●COVER ASSY, TANK, SOLTN FILL (AFTER SN 10514502)	2
54	41578	WASHER, FLAT, 06, SS (AFTER SN 10514502)	2
55	1034637	LABEL, FRONT 3.50 [NOBLES ICON]	1

PARTS LIST

RECOVERY TANK GROUP (S/N 10430222-)

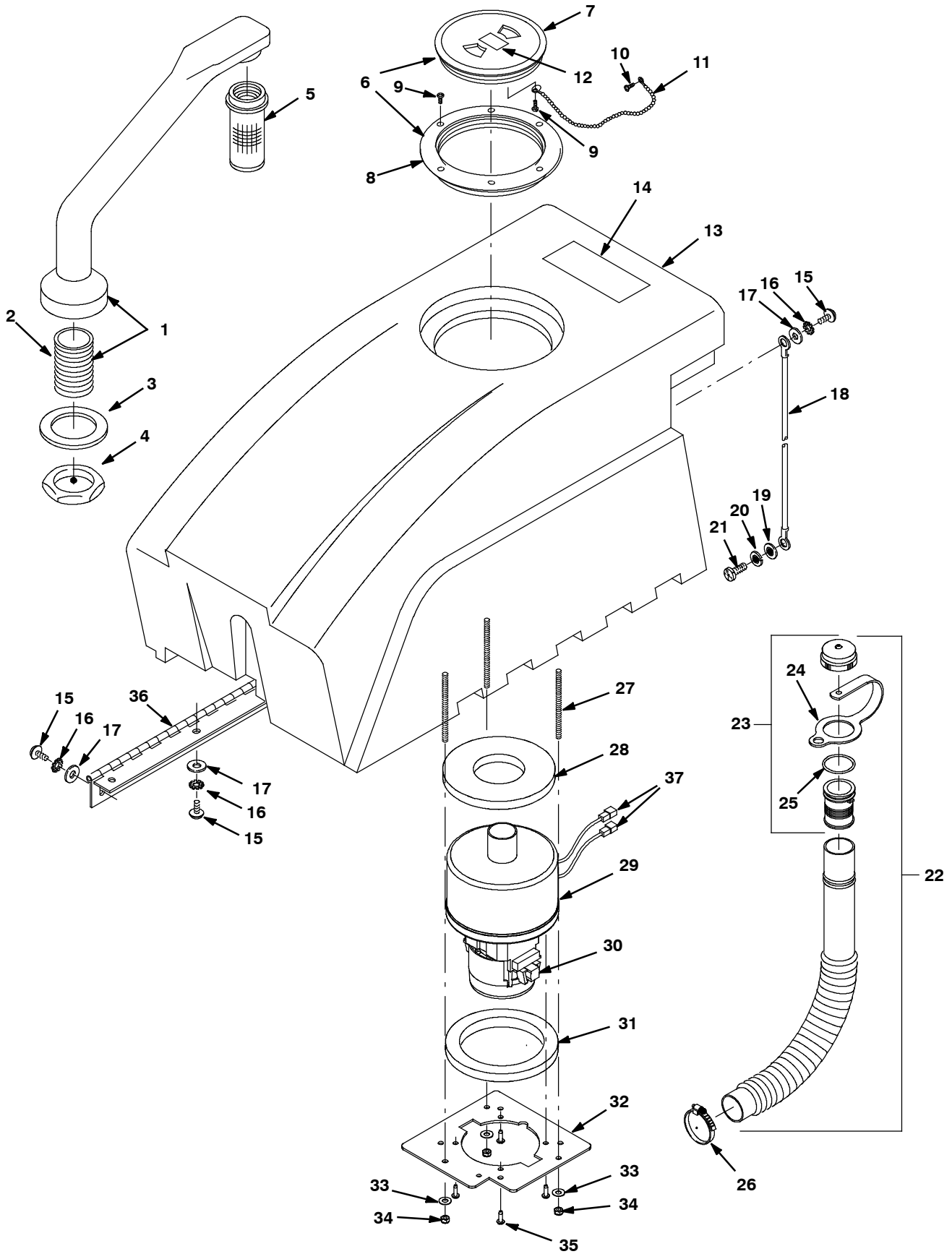

RECOVERY TANK GROUP (S/N 10430222-)

REF	PART #	DESCRIPTION	QTY.
▽ 1	701103	ASM.,STANDPIPE	1
▲ 2	606088	NIPPLE	1
3	101714	●GASKET	1
4	210240	NUT, FLANGED	1
5	180613	●FLOAT, SHUTOFF	1
▽ 6	100102	●ASM.,LID CLEAR W/STD HOLE	1
▲ 7	100105	●LID, CENTER CLEAR ONLY	1
▲ 8	100109	●LID, OUTER RING ONLY	1
9	140826	SCREW, #6X3/4	7
10	3701.6	SCREW, #6X3/8	1
11	230513	ASM., CHAIN	1
12	120906	DECAL, IMPORTANT DRAIN	1
▽ 13	614373	TANK, REC, GREEN W/LABEL	1
▲ 14	1026386	LABEL, WARNING [EXPL, FIRE, SHK EN/FR/ES]	1
15	578187000	SCREW, M06X12MM	12
16	140052	WASHER, LOCK	12
17	140000	WASHER, FLAT	12
18	140960	CABLE, SUPPORT	1
19	140027	WASHER, FLAT	1
20	140015	WASHER, LOCK	1
21	16931	SCREW, HEX, M8 X 1.25 X 20, 8.8	1

▽ ASSEMBLY

▲ INCLUDED IN ASSEMBLY

● RECOMMENDED STOCK ITEMS

REF	PART #	DESCRIPTION	QTY.
▽ 22	1010143	●HOSE, DRAIN, ASSY, 1.5D X 32.3L, BLK	1
▲▽ 23	1008639	●ASM., CAP, DRAIN HOSE	1
▲▲ 24	1019563	●STRAP, DRAIN CAP	1
▲▲ 25	1008637	●O RING, 1.48" ID, 1.76" OD	1
26	614157	CLAMP, HOSE, WORMDRIVE, 1.06- 2.00D, .50W	1
27	604137	SCREW, STUD, M6 X 1.00 X 127, PL (AFTER SN 10430222)	3
28	100038	●GASKET, .50, 02.63ID 05.75OD, ADH (AFTER SN 10430222)	1
▽ 29	130397	●FAN, VACUUM, 5.7D, 024VDC, 3 STAGE [(AFTER SN 10430222)	1
▲ 30	1073334	●BRUSH, CARBON, MOTOR, ELE [1PICK=1PKG] (1PKG=2 BRUSHES) (AFTER SN 10430222)	1
31	100143	●GASKET, MOTOR, VACUUM, 5.7 (AFTER SN 10430222)	1
32	1055851	PLATE, MOUNT, MOTOR (AFTER SN 10430222)	1
33	140000	WASHER, FLAT, 0.28B 0.62D .04 SS (AFTER SN 10430222)	3
34	08712	NUT, HEX, LOCK, M6 X 1.00, NL, SS (AFTER SN 10430222)	3
35	140340	SCREW, PAN, PHL, 10- 24 X 0.62, SS (AFTER SN 10430222)	4
36	600311	●HINGE, RECOVERY TANK	1
37	130192	TERMINAL, MAL .25 12- 10GA YEL, F- INS	2

PARTS LIST

RECOVERY TANK GROUP (S/N 0000000- 10430221)

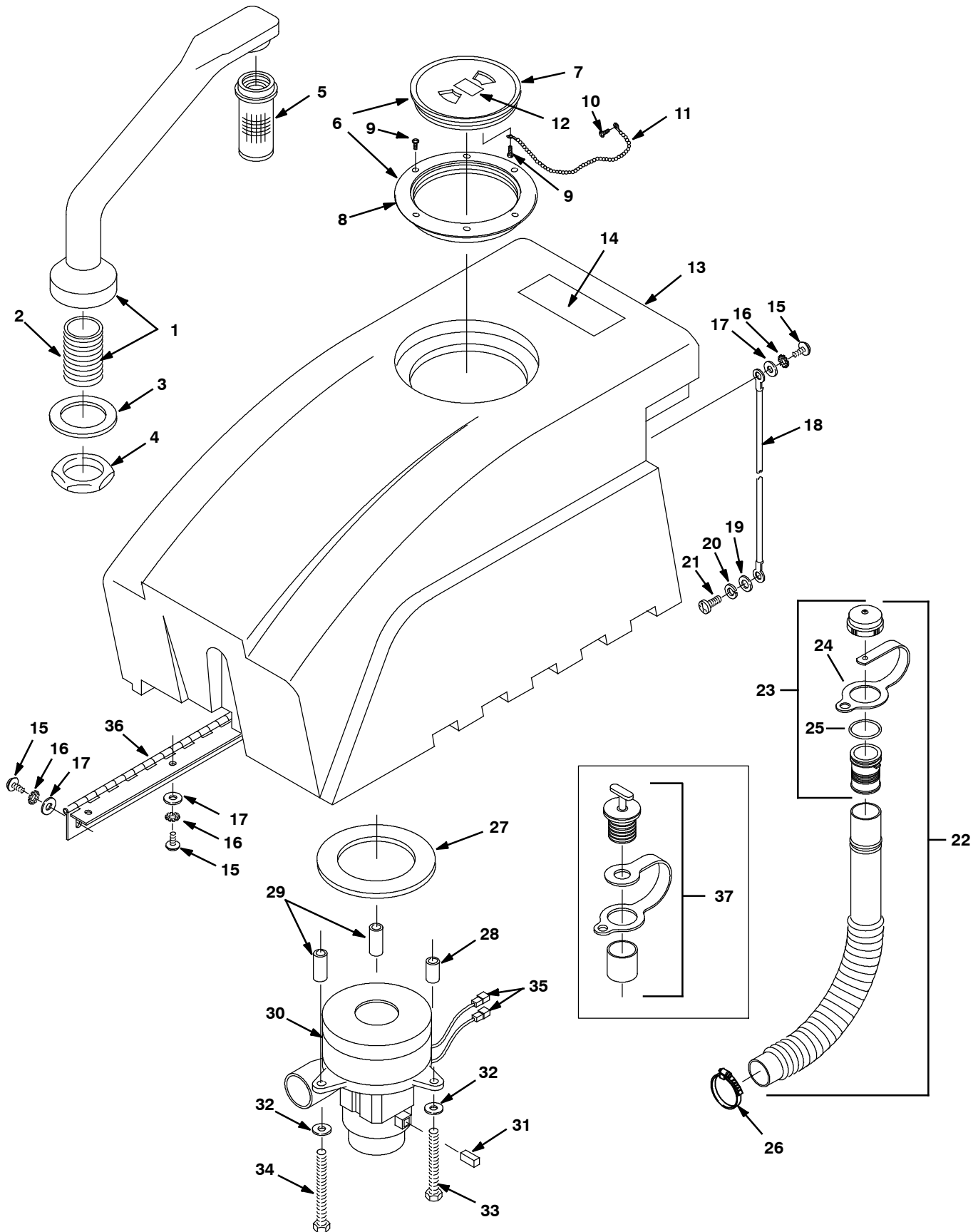

RECOVERY TANK GROUP (S/N 0000000- 10430221)

REF	PART #	DESCRIPTION	QTY.
∇ 1	701103	ASM.,STANDPIPE	1
▲ 2	606088	NIPPLE	1
3	101714	●GASKET	1
4	210240	NUT, FLANGED	1
5	180613	●FLOAT, SHUTOFF	1
∇ 6	100102	●ASM.,LID CLEAR W/STD HOLE	1
▲ 7	100105	●LID, CENTER CLEAR ONLY	1
▲ 8	100109	●LID, OUTER RING ONLY	1
9	140826	SCREW, #6X3/4	7
10	3701.6	SCREW, #6X3/8	1
11	230513	ASM., CHAIN	1
12	120906	DECAL, IMPORTANT DRAIN	1
∇ 13	614373	TANK, REC, GREEN W/LABEL	1
▲ 14	1026386	LABEL, WARNING [EXPL, FIRE, SHK EN/FR/ES]	1
15	578187000	SCREW, M06X12MM	12
16	140052	WASHER, LOCK	12
17	140000	WASHER, FLAT	12
18	140960	CABLE, SUPPORT	1
19	140027	WASHER, FLAT	1
20	140015	WASHER, LOCK	1
21	16931	SCREW, HEX, M8 X 1.25 X 20, 8.8	1

∇ ASSEMBLY

▲ INCLUDED IN ASSEMBLY

● RECOMMENDED STOCK ITEMS

REF	PART #	DESCRIPTION	QTY.
∇ 22	1010143	●HOSE, DRAIN, ASSY, 1.5D X 32.3L, BLK	1
▲∇ 23	1008639	●ASM., CAP, DRAIN HOSE	1
▲▲ 24	1019563	●STRAP, DRAIN CAP	1
▲▲ 25	1008637	●O RING, 1.48" ID, 1.76" OD	1
26	614157	CLAMP, HOSE, WORMDRIVE, 1.06- 2.00D, .50W	1
27	100001	●GASKET, VAC MOTOR (BEFORE SN 10430222)	1
28	019686055	SPACER 6.5X15.8X6.4 (BEFORE SN 10430222)	1
29	603963	SPACER 6.5X12.7X41.2 (BEFORE SN 10430222)	2
30	602656	●MOTOR, VAC 7.2 2 STG 24 VDC (BEFORE SN 10430222) (REPLACED BY 9006571)	1
31	604403	CARBON BRUSH, SET OF 2 (BEFORE SN 10430222)	1
32	140000	WASHER, FLAT (BEFORE SN 10430222)	3
33	06944	SCREW, HEX, M6 X 1.00 X 25, 8.8 (BEFORE SN 10430222)	1
34	58979	SCREW, HEX, M6 X 1.00 X 55, FL (BEFORE SN 10430222)	2
35	130192	TERMINAL, MALE 1/4 #10 12- 10	2
36	600311	●HINGE, RECOVERY TANK	1
37	N/A	DRAIN HOSE ASSEMBLY (REPLACED BY 1010143 ITEM #22)	1

CONSOLE GROUP

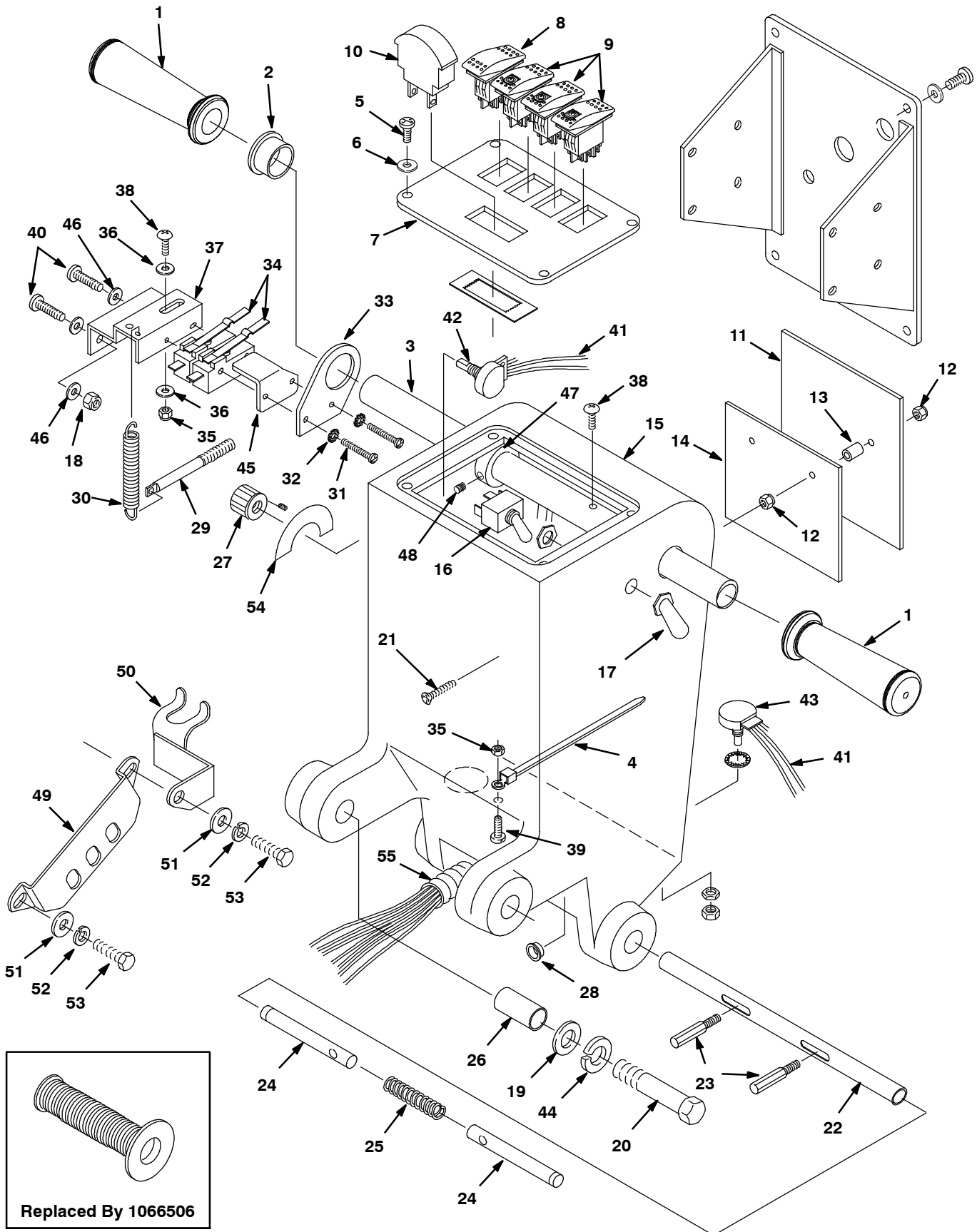

CONSOLE GROUP

REF	PART #	DESCRIPTION	QTY.
1	1066506	GRIP, HANDLE, RND	2
2	605351	BUSHING	1
3	604402	HANDLE, TUBE	1
4	605321	CABLE TIE	1
5	578141000	SCREW, M5X10MM	4
6	07514	WASHER, LOCK, INT, 10, SS	4
7	602978	PANEL, CONTROL W/SILKSCREEN	1
8	602919	●SWITCH, DPDT ON/ON	1
9	601107	●SWITCH, LIGHTED ROCKER	3
10	606020	METER, BATTERY VOLTAGE 24V	1
11	630104	●SPEED CONTROL, PMB, 55 AMP	1
12	02850	NUT, HEX, LOCK, M4 X 0.70, NL	4
13	630261	SPACER	2
14	630128	HEAT SINK	1
15	608299	HOUSING, CONTROL, GREEN	1
16	601108	●SWITCH, TOGGLE	1
17	130753	BOOT, SWITCH	1
18	08712	NUT, HEX, LOCK, M6 X 1.00, NL, SS	2
19	140045	WASHER, FLAT	2
20	140351	SCREW, M12X1.75X70MM	2
21	630304	SCREW, M4X35MM	2
22	230715	TUBE, HANDLE ADJUSTMENT	1
23	230649	PIN, HANDLE ADJUSTMENT	2
24	230710	PIN, HANDLE LOCK	2
25	140415	SPRING, LOCK PIN	1
26	140155	BUSHING	2
27	606550	KNOB, SPEED CONTROL	1
28	603007	BUSHING, SNAP	1

REF	PART #	DESCRIPTION	QTY.
29	602886	PIN, SPRING RETURN	1
30	605812	SPRING, EXPANSION	1
31	140830	SCREW 6- 32X1 - 5/8	2
32	140019	WASHER, LOCK	2
33	27098	BRACKET, SWITCH	1
34	614003	●SWITCH, SNAP ACTION W/BUMP	2
35	140552	NUT	2
36	19066	WASHER, FLAT, 0.25B 0.56D .05, PL, 10	2
37	25671	MOUNT, SWITCH	1
38	140890	SCREW. 10- 24X1/2	2
39	140900	SCREW 10- 24X3/4	1
40	608322	SCREW, M6X1.0X16MM	2
∇ 41	602873	HARNESS, CONSOLE W/POTS	1
▲ 42	130776	●POTENTIOMETER, 50K	1
▲ 43	130775	●POTENTIOMETER, 50K LOCKABLE	1
44	140024	WASHER, LOCK	2
45	603830	PLATE, GUARD SWITCH	1
46	140000	WASHER, 1/4 FLAT	4
47	605094	COLLAR, HANDLE	2
48	140859	SCREW, 1/4 SK	2
49	230661	PLATE, LOCK CONTROL HOUSING	2
50	611979	WELDMENT, DRAIN HOSE	1
51	140027	WASHER, FLAT	4
52	140015	WASHER, LOCK	4
53	16931	SCREW, HEX, M8 X 1.25 X 20, 8.8	4
54	606549	DECAL, SPEED CONTROL	1
55	613092	●HARNESS, WIRE MAIN	1
	604486	ASM., DIODE SPLICED	1

∇ ASSEMBLY

▲ INCLUDED IN ASSEMBLY

● RECOMMENDED STOCK ITEMS

CONTROL PANEL GROUP

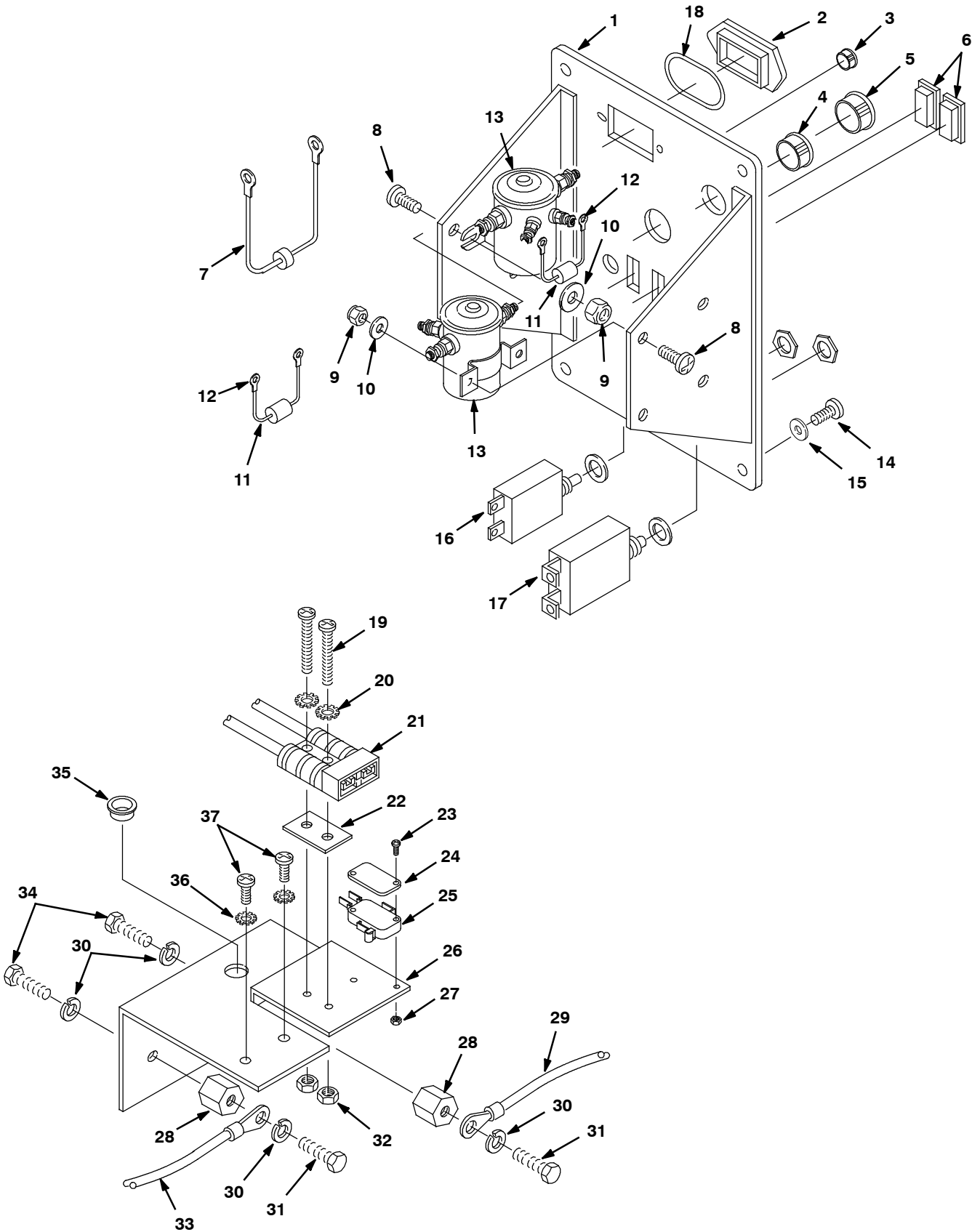

CONTROL PANEL GROUP

REF	PART #	DESCRIPTION	QTY.
1	602559	PANEL, CONTROL HOUSING	1
2	609969	PLUG, HOUR METER	1
3	069764626	PLUG, HOLE 012.7	1
4	130161	PLUG, DOME .875	1
5	130175	PLUG, DOME .750	1
6	582150	PLUG, ACCESSORY SWITCH	2
7	604486	DIODE, ASSY SPLICED	1
8	608322	SCREW, M6X1.0X20MM	6
9	140284	NUT	4
10	140000	WASHER, FLAT	4
▽ 11	606404	●ASM., DIODE W/RING TERM.	2
▲ 12	281001009	RING, TERMINAL #10	4
13	605905	●SOLENOID, 24V	2
14	578141000	SCREW M5X10 PANPHL	4
15	140018	WASHER #10 INT	4
16	603487	●CIRCUITBREAKER, 15.0A BRUSH	1
17	130739	●CIRCUITBREAKER, 60AMP	1
18	605823	O RING .926ID X .996OD	1
19	140829	SCREW, 6- 32X1	2

REF	PART #	DESCRIPTION	QTY.
20	140019	WASHER, LOCK	2
21	605387	CONNECTOR, 50A WO/CONTACTS	1
22	603331	SPACER, CHARGER PLUG	1
23	578403000	SCREW, M3X20MM	2
24	601359	PLATE, SWITCH BACKING	1
25	600437	●SWITCH, ROLLER	1
26	603191	BRACKET, CHGR W/STANDOFF	1
27	579211	NUT, LOCK	2
28	76062	INSULATOR, PANEL & SWITCHBOARD	2
29	602871	CABLE, BATTERY #6 BLACKX24"	1
30	140016	WASHER, LOCK	4
31	01697	SCREW, HEX, .25- 20 X 0.62, SS	2
32	140539	NUT	2
33	603192	ASM., WIRE #6X650MM RED	1
34	140553	SCREW, 1/4- 20X1/2	2
35	130698	BUSHING, SNAP	1
36	140018	WASHER, #10 INT	2

▽ ASSEMBLY

▲ INCLUDED IN ASSEMBLY

● RECOMMENDED STOCK ITEMS

LIFT GROUP

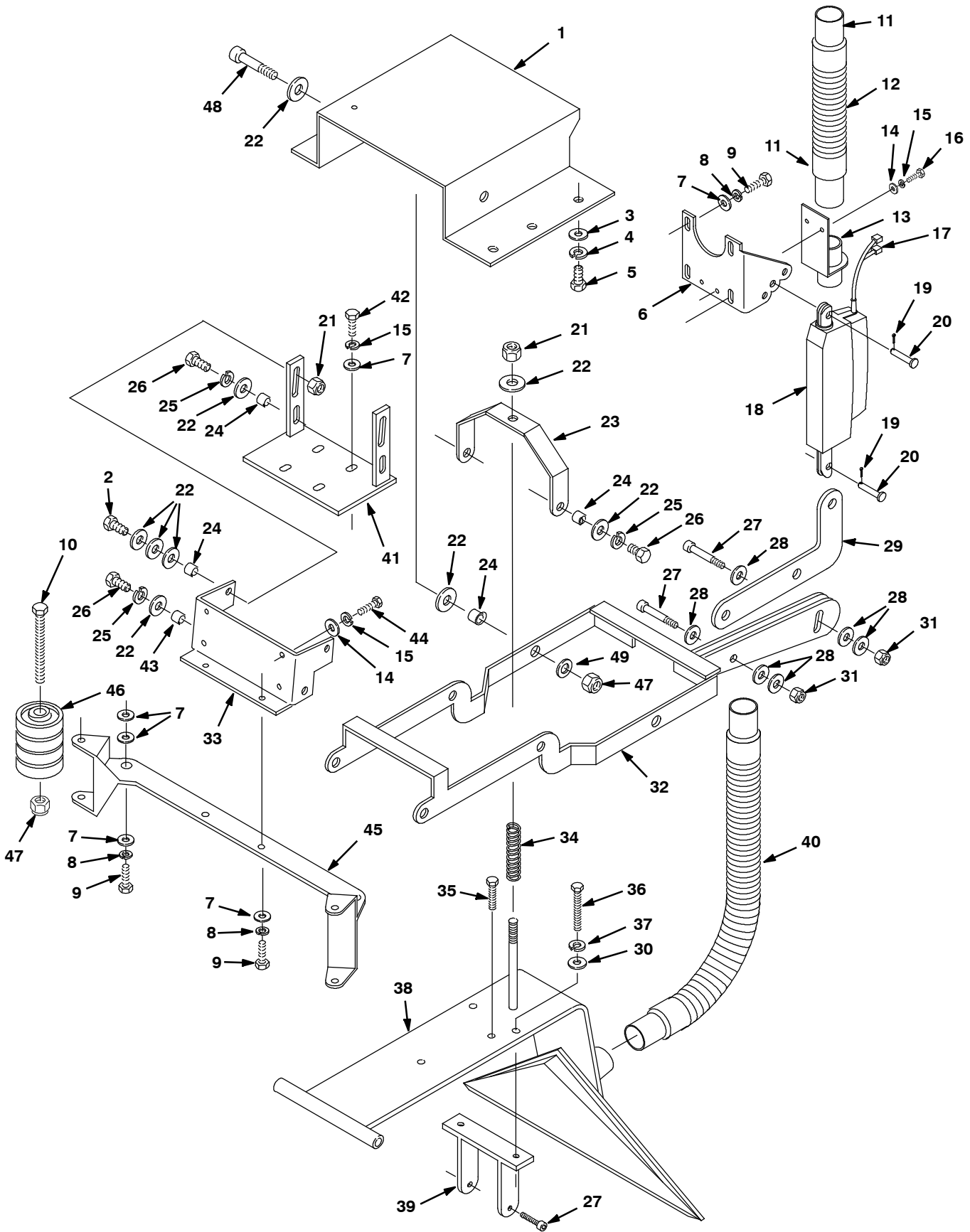

LIFT GROUP

REF	PART #	DESCRIPTION	QTY.
1	612782	PLATE, BASE TRANSAXLE	1
2	140236	SCREW, 1/2- 13X1 1/4	2
3	140028	WASHER, FLAT	2
4	140333	WASHER, LOCK	2
5	09291	SCREW, HEX, M10 X 1.5 X 20	2
6	1002936	BRACKET, ACTUATOR	1
7	140027	WASHER, FLAT	16
8	140015	WASHER, LOCK	8
9	16931	SCREW, HEX, M8 X 1.25 X 20, 8.8	8
10	590248	SCREW, 38- 16X4.75	2
11	160486	●CUFF, HOSE	1
12	160426	●HOSE, VAC 1.5X15" W/CUFF	1
13	603084	BRACKET, VAC HOSE	1
14	140000	WASHER, FLAT	2
15	140016	WASHER, LOCK	10
16	48732	SCREW, PAN, PHL, M6 X 1.00 X 10	2
17	130129	TERMINAL, FM DSCNT 22- 18 RED	2
18	600952	●ACTUATOR, 24VDC	1
19	604076	PIN, CLEVIS	2
20	578421	PIN, COTTER	2
21	02931	NUT, HEX, LOCK, .50- 13, NL, SS	3
22	140045	WASHER, FLAT	17
23	602567	BRACKET, SPRING	1
24	602882	BUSHING	8
25	140024	WASHER, LOCK	6

● RECOMMENDED STOCK ITEMS

REF	PART #	DESCRIPTION	QTY.
26	09745	SCREW, HEX, M12 X 1.75 X 25, SS	6
27	140564	BOLT, SHOULDER 3/8X3/4	4
28	140036	WASHER, FLAT	6
29	603044	PLATE, ACTUATOR LIFT	1
30	140027	WASHER, FLAT	2
31	140546	NUT, NYLOCK	2
32	612781	LIFT BRACKET, EXTRACTOR	1
33	602977	BRACKET, MOUNT CARPET TOOL	1
34	602565	SPRING, CARPET TOOL	1
35	140221	SCREW, 5/16- 18X1 1/4	2
36	140220	SCREW, 5/16- 18X2 1/2	2
37	140015	WASHER, LOCK	4
38	600306	TOOL, CARPET 22"	1
39	603046	BRACKET, BASE LEVELER	1
40	160613	●HOSE, VAC 1.5X30" W/CUFFS	1
41	600307	BRACKET, MOUNT EXTRACTOR	1
42	140226	SCREW, 5/16- 18X5/8	4
43	140139	SLEEVE	2
44	15678	SCREW, HEX, M6 X 1.00 X 16, SS	4
45	603093	BRACKET, BUMPER WHEEL	1
46	630477	WHEEL, 2" GRAY	8
47	59156	NUT, HEX, LOCK, .38- 16, NL, SS	4
48	36758	BOLT, SHOULDER	2
49	140046	WASHER, 1.00X.392X.090	2

DRIVE GROUP

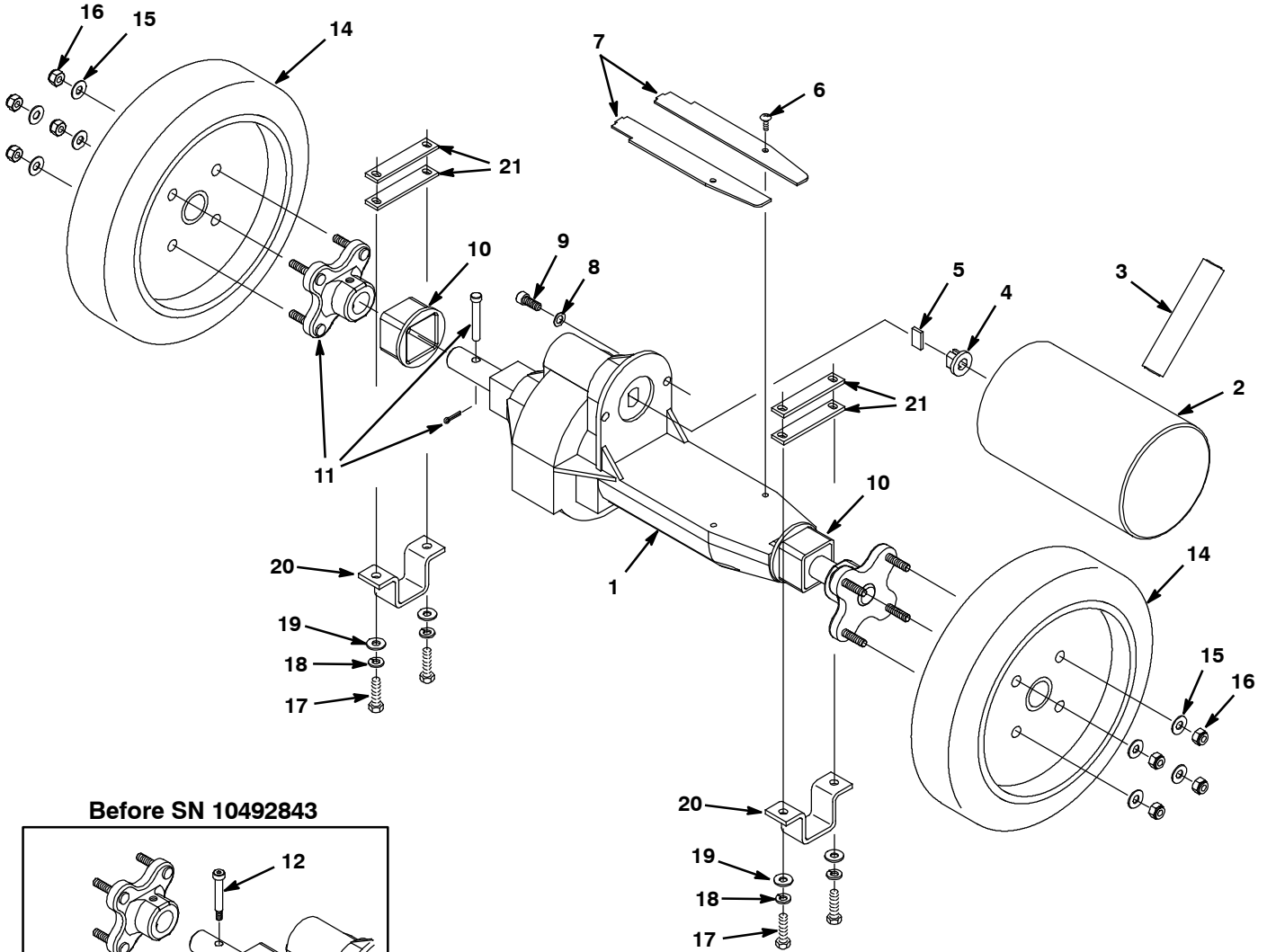

Before SN 10492843

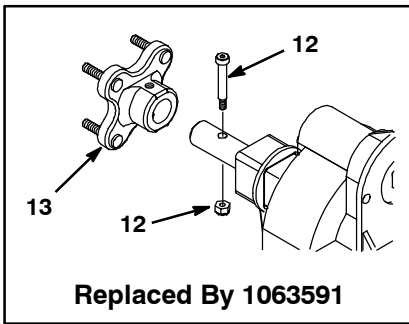

DRIVE GROUP

REF	PART #	DESCRIPTION	QTY.
▽	1013312	TRANSAXLE, 24V MOTOR, 116RPM	1
▲ 1	612873	TRANSAXLE, REPLMT, BODY ONLY	1
▲▽ 2	614165	●MOTOR, ELE, 24VDC TRANSAXLE REPLMNT KIT (After SN 10170826)	1
	612877	●MOTOR, REPLMT, 24V- 612844 TRANSAXLE (Before SN 10170826) (REPLACED BY 614165)	1
▲▲ 3	614166	●KIT, BRUSH CARBON QTY (4) (After SN 10170826) (FOR MOTOR #614165)	1
	612883	●KIT, BRUSH CARBON QTY (2) (Before SN 10170826) (FOR MOTOR #612877)	1
▲▲ 4	612874	COUPLING, TRANSAXLE REPLMT	1
▲▲ 5	612875	KEY, SPECIAL, TRANSAXLE REPLMT	1
▲▲ 6	577031000	SCREW, #8X1/2 PANPHL ZN	2
▲▲ 7	N/A	COVER, SHAFT	2
▲▲ 8	32982	WASHER, LOCK, INT, 0.25	2
▲▲ 9	33951	SCREW, SOC, .25- 20 X 0.62, BO	2
▲ 10	612880	SLEEVE, TRANSAXLE REPLMT	2

REF	PART #	DESCRIPTION	QTY.
▲ 11	1063591	RETAINER, HUB, TRANSAXLE WHEEL (After SN 10492843) (KIT INCLUDES 1 EACH - HUB, CLEVIS PIN & COTTER PIN)	2
12	1043275	BOLT KIT, TRANSAXLE (Before SN 10492843) (REPLACED BY 1063591)	2
13	612879	HUB, WHEEL, TRANSAXLE RPLMT (Before SN 10492843) (REPLACED BY 1063591)	2
14	607452	WHEEL, 8.0D 2.00W TPR	2
15	140000	WASHER, 1/4 FLAT	8
16	41169	NUT, HEX, LOCK, .25- 20 NL, SS	8
17	612255000	SCREW, M10X35MM	4
18	140333	WASHER, LOCK M10	4
19	140028	WASHER, 3/8 FLAT	4
20	612784	BRACKET, MTG, TRANSAXLE, YEL PL [UNIVSL]	2
21	612783	SPACER, AXLE	4
N/S	130041	WIRE TIE, NYLON	2

▽ ASSEMBLY

▲ INCLUDED IN ASSEMBLY

● RECOMMENDED STOCK ITEMS

BRUSH BASE GROUP

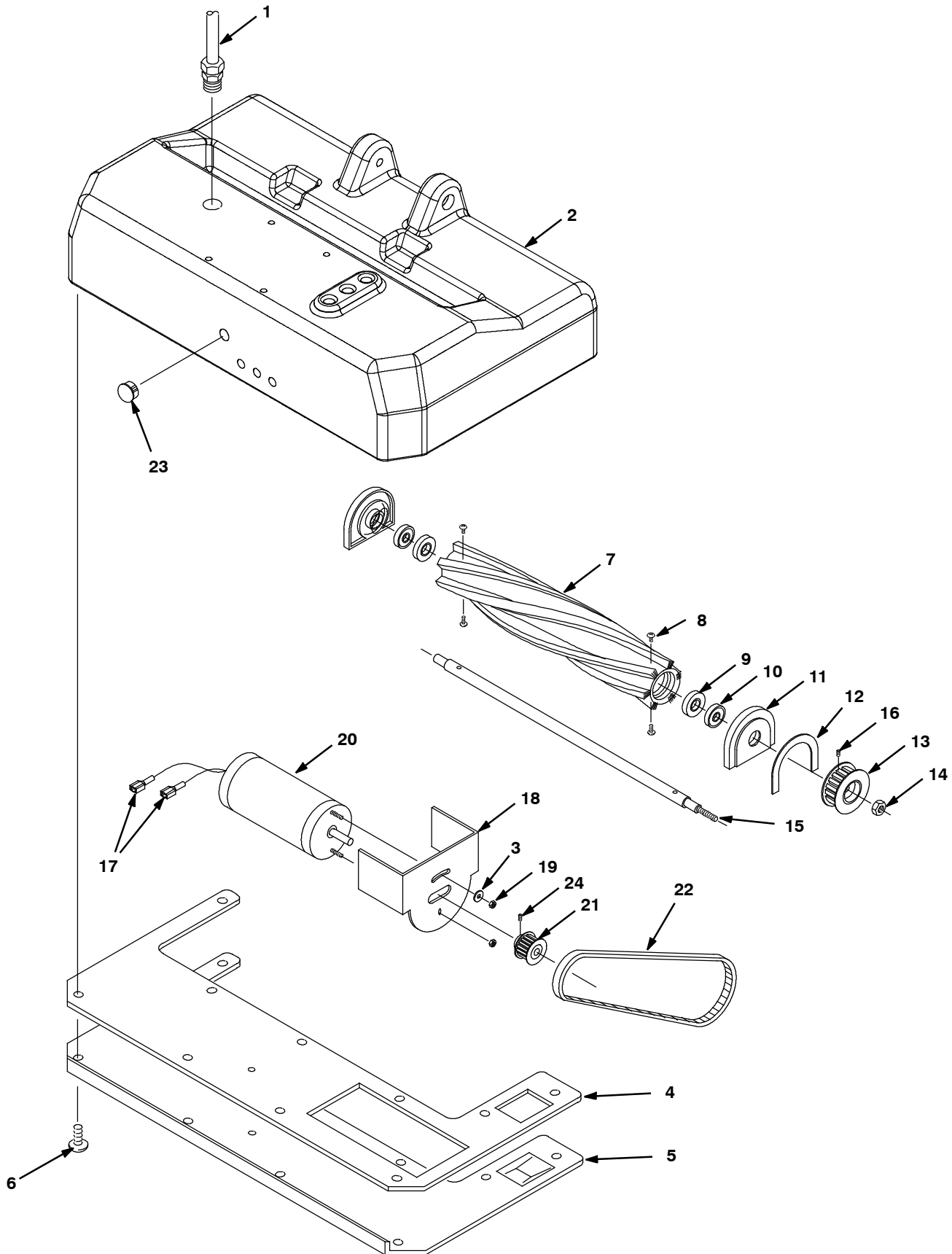

BRUSH BASE GROUP

REF	PART #	DESCRIPTION	QTY.	
1	603193	CORD, 16/2X33 SJT	1	
2	101106	BASE, 22"	1	
3	200315016	WASHER, FLAT	1	
4	100157	GASKET, BASE PLATE	1	
5	611919	PLATE, BASE	1	
6	140197	SCREW, 10- 24X3/8 TRSPHL	11	
∇	700422	●ASM., BRUSH	1	
▲	7	240063	BRUSH, CYLINDER	1
▲	8	24672	SCREW, HEX, .25- 20 X 0.75, SS	4
▲	9	100049	SEAL, BRUSH BEARING	2
▲	10	140125	BEARING, BRUSH	2
▲	11	230261	BLOCK, BEARING	2
▲	12	100005	GASKET, BEARING BLOCK	1

REF	PART #	DESCRIPTION	QTY.	
▲	13	230408	PULLEY, BRUSH	1
▲	14	140548	NUT 5/16	1
▲	15	230406	SHAFT, BRUSH 22"	1
▲	16	140859	SCREW, SET 1/4- 20X1/4	1
	17	130096	TERMINAL, MALE DSCNT 16- 14	2
	18	230411	BRACKET, BRUSH MOTOR	1
	19	140518	NUT, KEP 10- 32	2
	20	602965	●MOTOR, BRUSH DRIVE 24 VDC	1
	21	230410	●PULLEY, MOTOR	1
	22	230409	●BELT, TIMING	1
	23	130154	DOME PLUG	1
	24	140859	SCREW, SET 1/4- 20X1/4	1

∇ ASSEMBLY

▲ INCLUDED IN ASSEMBLY

● RECOMMENDED STOCK ITEMS

SOLUTION GROUP

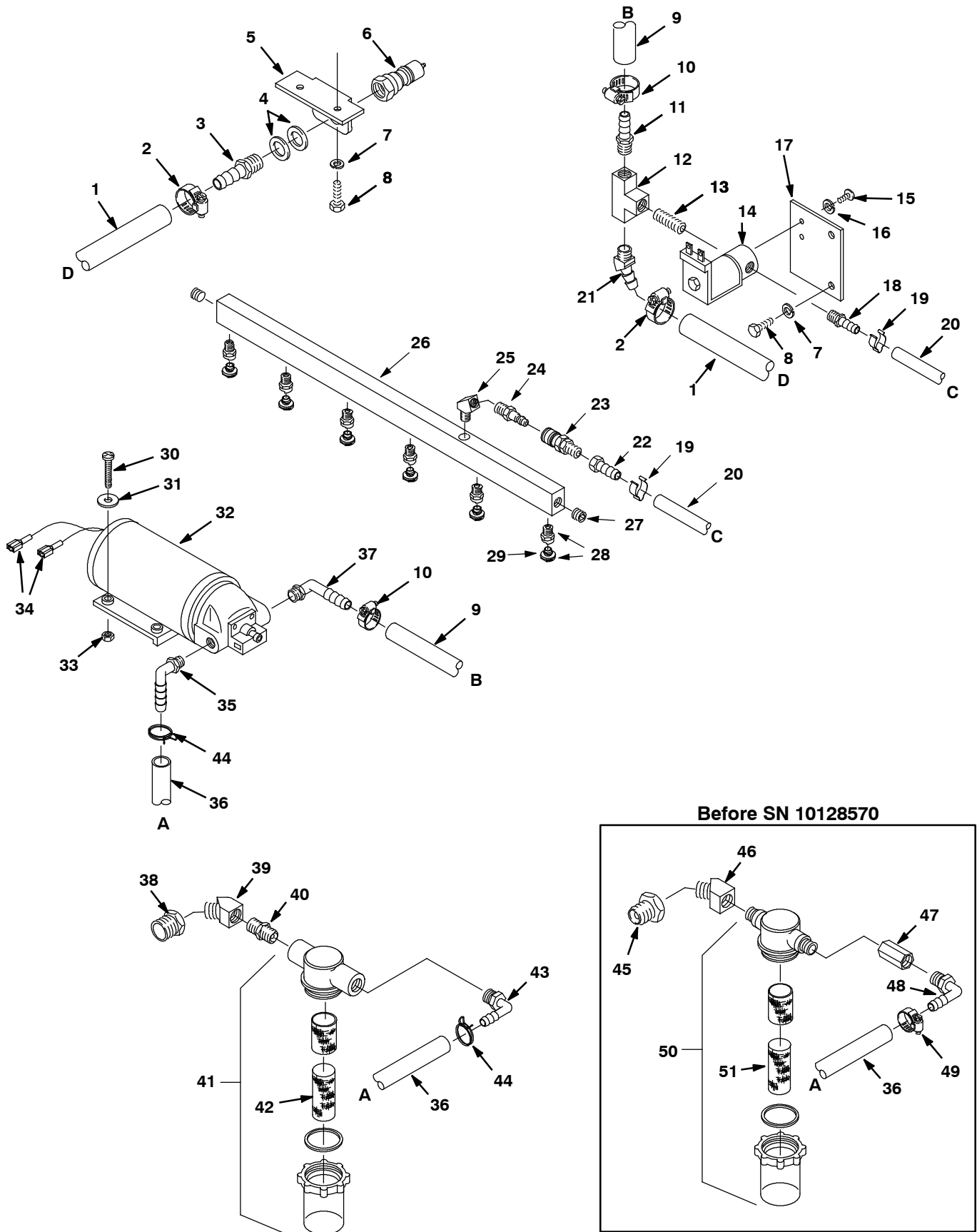

SOLUTION GROUP

REF	PART #	DESCRIPTION	QTY.
1	607704	HOSE, 3/8" X 24.5"	1
2	140310	CLAMP, HOSE	2
3	150516	FITTING, 1/4MX3/8H BARB	1
4	140058	WASHER	2
5	603063	BRACKET, QC MOUNT	1
6	150933	PLUG, QUICK COUPLER	1
7	140016	WASHER, LOCK	4
8	578187000	SCREW, M06X12MM	4
9	607705	HOSE, 1/2" X 24" RED	1
10	630369	CLAMP, HOSE	2
11	150517	FITTING, 1/4MX1/2H BARB	1
12	150706	FITTING, TEE	1
13	150615	NIPPLE, 1/4 CLOSE	1
14	607473	●SOLENOID, WATER 24 VDC	1
15	140801	SCREW, 8- 32X3/8	2
16	140023	WASHER, LOCK	2
17	603055	BRACKET, SOLENOID	1
18	150515	FITTING, 4H BARB	1
19	140325	CLAMP	2
20	607706	HOSE, 1/4" X18"	1
21	605394	FITTING, 1/4MX3/8H BARB 45°	1
22	150520	FITTING, 1/8FX1/4H BARB	1
23	150915	COUPLER, QUICK	1
▽	700423	ASM., SPRAY BAR	1
▲	150921	PLUG, QUICK COUPLER	1
▲	150422	FITTING, 1/8MX1/8F ELB STRT 45°	1
▲	230407	MANIFOLD, SPRAYBAR 22"	1
▲	150208	PLUG	2

▽ ASSEMBLY

▲ INCLUDED IN ASSEMBLY

● RECOMMENDED STOCK ITEMS

REF	PART #	DESCRIPTION	QTY.
▲▽	28	201011 ●NOZZLE, TWISTOUT (80015)	6
▲▲	29	201013 ●TIP, REPLACEMENT FOR #80015	1
		201015 ●SEAL, SPRAY NOZZLE	1
	30	140899 SCREW, 10- 24X1 1/4	2
	31	140012 WASHER, FLAT	2
	32	603031 ●PUMP, SOL, ELE, 24VDC 100PSI	1
	33	140552 NUT, NYLOCK	2
	34	130096 TERMINAL, MALE .25	2
	35	150412 FITTING. 3/8MX3/8H ELBOW 90°	1
	36	607305 TUBING, 3/8" X 30" GRAY VINYL	1
	37	150425 FITTING, 3/8MX1/2H ELBOW 90°	1
▽		613981 KIT, REPLMT, FILTER, LARGE ID (Before SN 10128570)	1
▲	38	150107 FITTING, BRS, STR, PM08/PF06	1
▲	39	1043095 FITTING, BRS, E45, PF06/PM06	1
▲	40	150617 FITTING, BRS, STR, PM06 HEX NIPPLE, T	1
▲▽	41	1007428 ●FILTER, BOWL & SCREEN	1
▲▲	42	180638 ●FILTER, SCREEN, 125MESH NY, SLEEVE	1
▲	43	150412 FITTING, PLSTC, E90, PM06/BM06	1
▲	44	607775 CLAMP, HOSE .63- .66 2 WIRE BLK	2
	45	150101 FITTING, BUSHING	1
	46	150403 ELBOW, STREET 1/4X45°	1
	47	150302 COUPLING, 1/4FX1/4F	1
	48	150415 FITTING, 1/4MX3/8H ELBOW 90°	1
	49	54333 CLAMP, HOSE	2
▽	50	180619 ●FILTER, 1/4 NPT CLEAR BOWL	1
▲	51	180638 ●FILTER, SCREEN, 125MESH NY, SLEEVE	1

PARTS LIST

PUMP BREAKDOWN GROUP

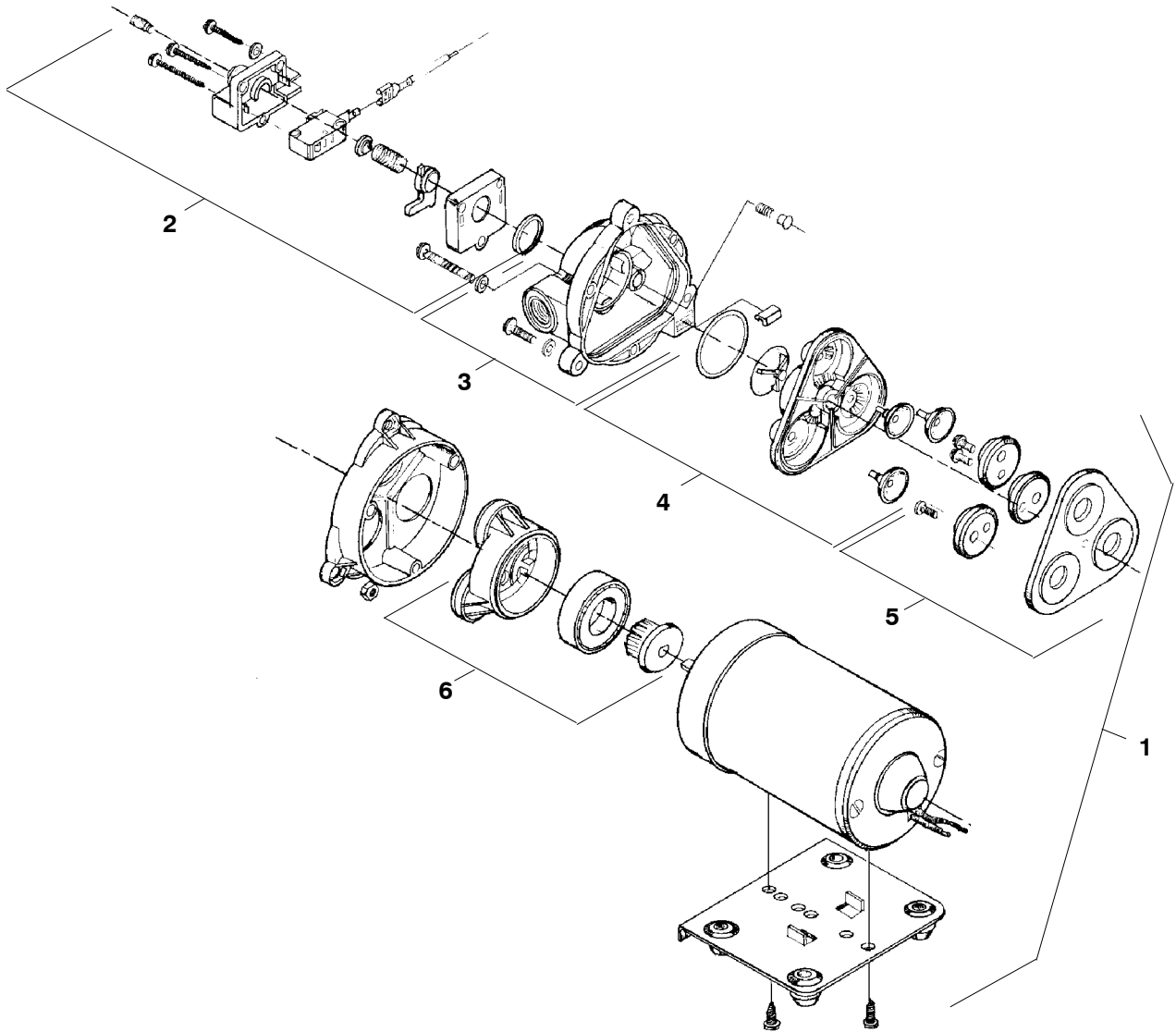

REF	PART #	DESCRIPTION	QTY.
▽ 1	603031	●PUMP, SOL, ELE, 24VDC 100PSI	1
▲ 2	190129	●KIT, PUMP PRESSURE SWITCH	1
	190172	●KIT, PUMP PRS SWITCH (VITON)	1
	190134	●KIT, PUMP DIAPHRAGM ONLY	1
▲ 3	190128	●KIT, PUMP UPPER HOUSING	1
	190124	●KIT, PUMP CHECK VALVE ONLY	1

REF	PART #	DESCRIPTION	QTY.
▲ 4	190171	●KIT, PUMP VALVE (VITON)	1
▲ 5	190131	●KIT, PUMP SERVICE	1
▲ 6	190130	●KIT, PUMP LOWER HOUSING	1

▽ ASSEMBLY

▲ INCLUDED IN ASSEMBLY

● RECOMMENDED STOCK ITEMS

BATTERY AND CHARGER GROUP

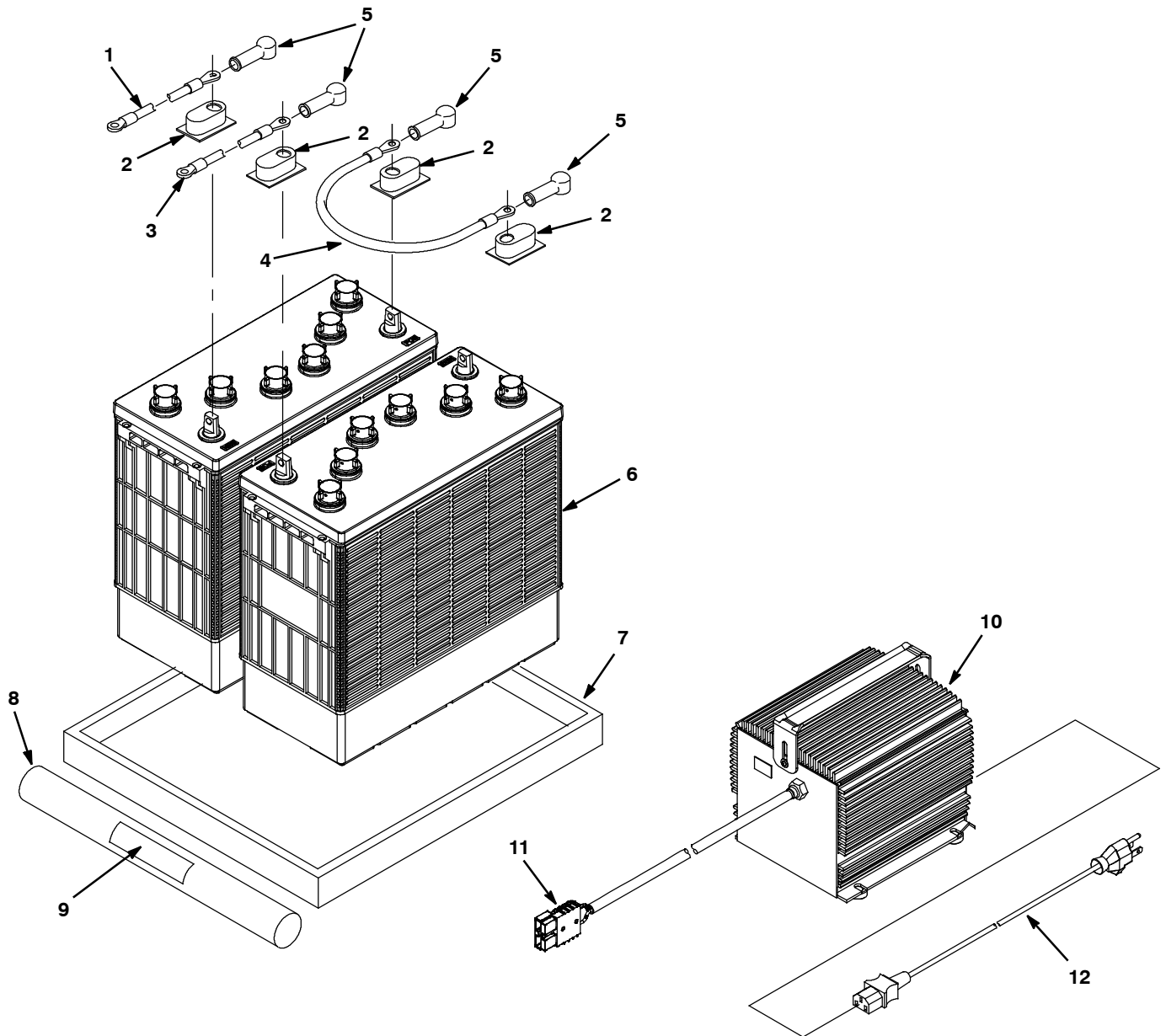

REF	PART #	DESCRIPTION	QTY.
1	602871	CABLE, BATTERY #6 BLACKX24"	1
2	45962	COVER, BATTERY TERMINAL	4
3	603192	ASM., WIRE #6X650MM RED	1
4	130364	CABLE, BATTERY #6 BLACKX15"	1
5	611221	●BOOT, BATTERY CABLE BLK	4
6	1070591	●BATTERY, WET, 12VDC 0225AH, W/ CARTON	2
7	601991	●TRAY, BATTERY	1

REF	PART #	DESCRIPTION	QTY.
8	602592	SUPPORT TUBE BATTERY	1
9	603828	DECAL, BATTERY PLACEMENT	1
▽ 10	1029256	●CHARGER 24VDC, 19A VAR VAC 1PH 50/60HZ	1
▲ 11	605387	CONNECTOR, ANDERSON, 50A, RED W/O CONTACT	1
▲ 12	1017079	CORD, EXTN, 16GA /3, 010FT	1

▽ ASSEMBLY

▲ INCLUDED IN ASSEMBLY

● RECOMMENDED STOCK ITEMS

WAND GROUP, LOW PRESSURE, 13 in / 330 mm

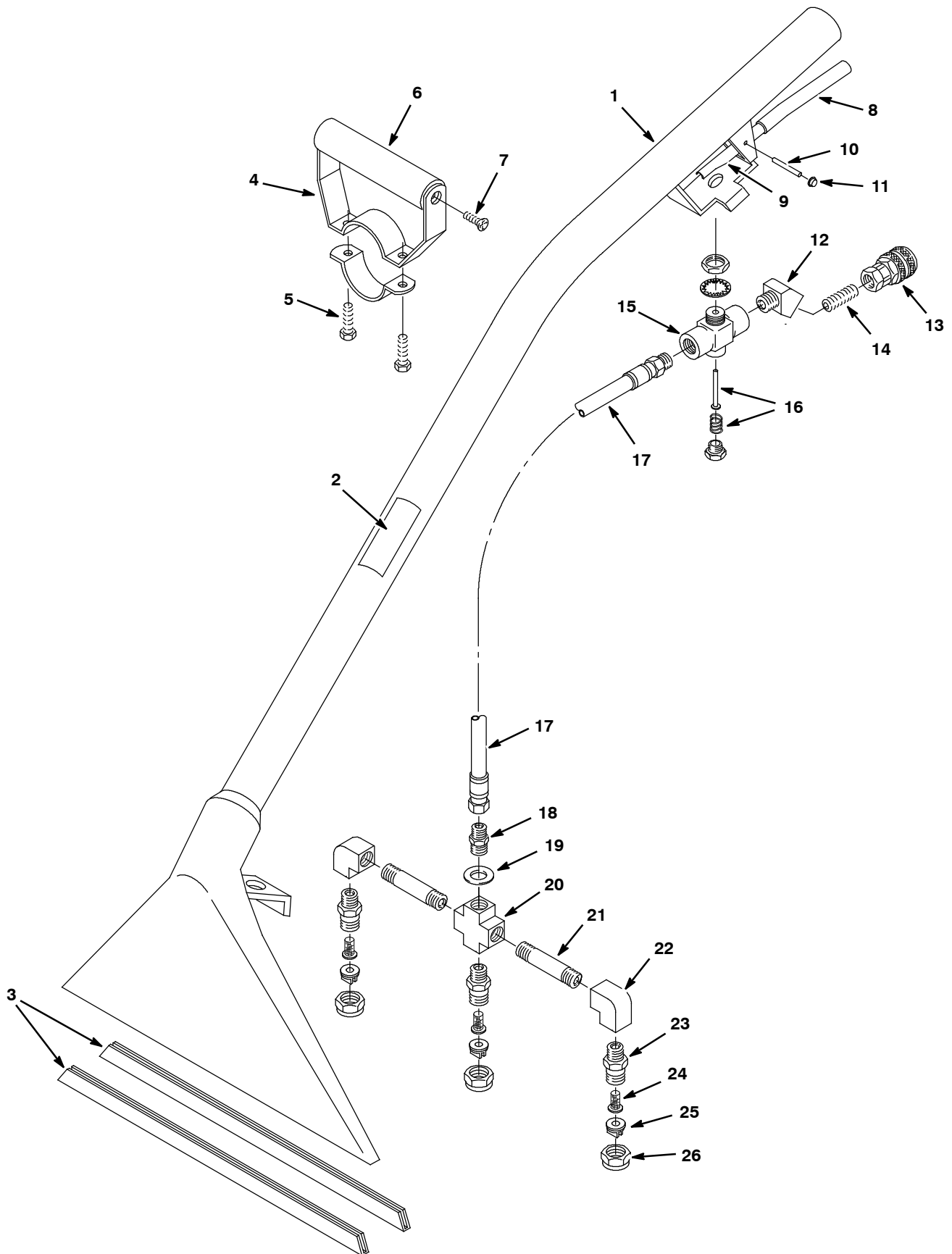

WAND GROUP, LOW PRESSURE, 13 in / 330 mm

REF	PART #	DESCRIPTION	QTY.
▽	600048	●TOOL, 330MM (13 IN) FLOOR LP SER 60	1
▲ 1	200403.BK	TOOL, FLOOR BLACK	1
▲ 2	120846	DECAL, LOW PRESSURE TOOL	1
▲ 3	200939	●SHOE, 330MM (13 IN) FLR TOOL	2
▲▽ 4	200927	●GRIP, HAND ADJ. COMPLETE	1
▲▲ 5	01697	SCREW, HEX .25- 20 X 0.62	2
▲▲ 6	200912	●GRIP, HANDLE FOAM	1
▲▲ 7	140834	SCREW, FLT .25- 20 X 0.62 PHL	2
▲ 8	200809	SLEEVE, HANDLE FLOOR TOOL	1
▲ 9	200902	HANDLE, IMPERIAL VALVE	1
▲ 10	140605	PIN, HANDLE IMPERIAL	1
▲ 11	140520	NUT, 1/4 PUSH BLK	2
▲ 12	150403	FITTING, BRS E45 PM04/PF04	1
▲ 13	150913	●FITTING, BRS QDC PF04 SER 60	1
▲ 14	150615	FITTING, BRS STR PM04 CLOSE	1

REF	PART #	DESCRIPTION	QTY.
▲▽ 15	210150	●VALVE, FLOW CONTROL PF04	1
▲▲ 16	190603	●KIT, REPAIR IMPERIAL	1
▲ 17	160170	WAND, HOSE ASSEMBLY 46"	1
▲ 18	150606	FITTING, BRS STR PM04 HEX NIP	1
▲ 19	140058	WASHER, .54B X .88D X .06 WAND	1
▲▽	700062	ASM., SPRAYBAR WO/TIPS	1
▲▲ 20	150700	FITTING, BRS TEE PF04 CROSS	1
▲▲ 21	150600	FITTING, 1/4MX2" NIPPLE BRS	2
▲▲ 22	150401	FITTING, BRS E90 PF04/PF04	2
▲▲ 23	200993	SPRAY BODY, 1/4" MALE BRASS	3
▲ 24	200996	●FILTER, SCREEN 100 MESH	3
▲ 25	200964	●FITTING, TIP 11003 T- JET BRS	3
▲ 26	200994	●CAP, NOZZLE SPRAY (8002)	3
N/S	200170	SQUEEGEE ASSY, 380MM/15.0, COMPL (OPTION - FOR HARD FLOOR SURFACES)	1

▽ ASSEMBLY

▲ INCLUDED IN ASSEMBLY

● RECOMMENDED STOCK ITEMS

WAND GROUP, LOW PRESSURE, 16 in / 406 mm

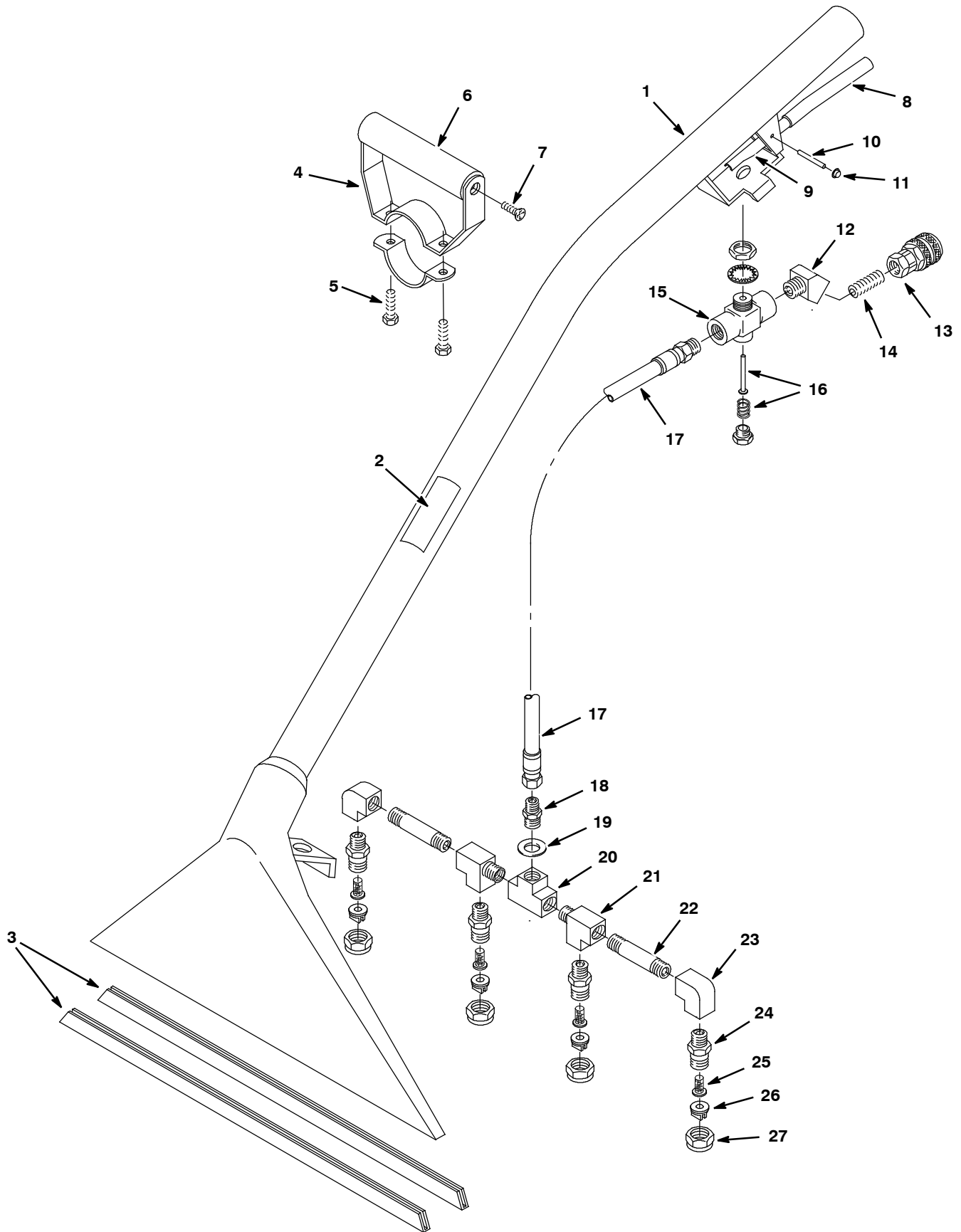

WAND GROUP, LOW PRESSURE, 16 in / 406 mm

REF	PART #	DESCRIPTION	QTY.
▽	200503	●TOOL, 406MM (16 IN) FLOOR LP SER 60	1
▲ 1	200411.BK	TOOL, FLOOR 406MM (16 IN)	1
▲ 2	120846	DECAL, LOW PRESSURE TOOL	1
▲ 3	200956	●SHOE, 406MM (16 IN) FLR TOOL	2
▲▽ 4	200927	●GRIP, HAND ADJ. COMPLETE	1
▲▲ 5	01697	SCREW, HEX .25- 20 X 0.62	2
▲▲ 6	200912	●GRIP, HANDLE FOAM	1
▲▲ 7	140834	SCREW, FLT .25- 20 X 0.62 PHL	2
▲ 8	200809	SLEEVE, HANDLE FLOOR TOOL	1
▲ 9	200902	HANDLE, IMPERIAL VALVE	1
▲ 10	140605	PIN, HANDLE IMPERIAL	1
▲ 11	140520	NUT, 1/4 PUSH BLK	2
▲ 12	150403	FITTING, BRS E45 PM04/PF04	1
▲ 13	150913	●FITTING, BRS QDC PF04 SER 60	1
▲ 14	150615	FITTING, BRS STR PM04 CLOSE	1

REF	PART #	DESCRIPTION	QTY.
▲▽ 15	210150	●VALVE, FLOW CONTROL PF04	1
▲▲ 16	190603	●KIT, REPAIR IMPERIAL	1
▲ 17	160170	WAND, HOSE ASSEMBLY 46"	1
▲ 18	150606	FITTING, BRS STR PM04 HEX NIP	1
▲ 19	140058	WASHER, .54B X .88D X .06 WAND	1
▲▽	700656	ASM., SPRAYBAR 16" WO/TIPS	1
▲▲ 20	150706	FITTING, BRS TEE PF04	1
▲▲ 21	150709	FITTING, BRS TEE PM04/PF04/PF04	2
▲▲ 22	150600	FITTING, 1/4MX2" NIPPLE BRS	2
▲▲ 23	150401	FITTING, BRS E90 PF04/PF04	2
▲▲ 24	200993	SPRAY BODY, 1/4" MALE BRASS	4
▲ 25	200996	●FILTER, SCREEN 100 MESH	4
▲ 26	200964	●FITTING, TIP 11003 T- JET BRS	4
▲ 27	200994	CAP, NOZZLE SPRAY (8002)	4

▽ ASSEMBLY

▲ INCLUDED IN ASSEMBLY

● RECOMMENDED STOCK ITEMS

HAND TOOL, 5 in / 127 mm

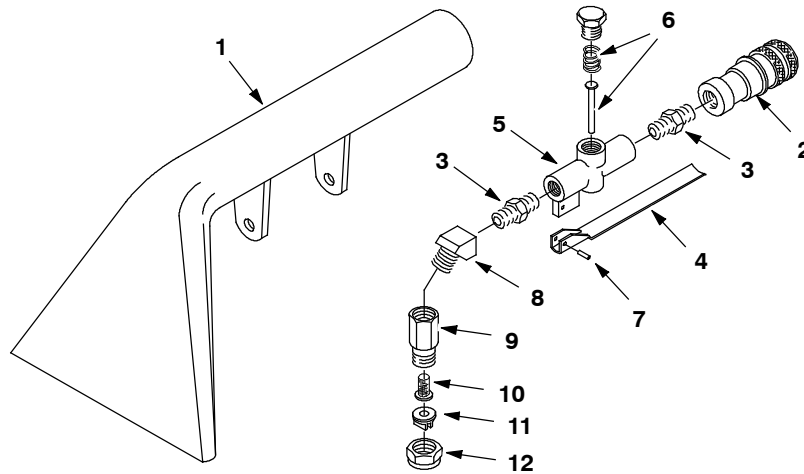

REF	PART #	DESCRIPTION	QTY.
▽	200505	●ASM., HAND TOOL 5" SERIES 60	1
▲ 1	200431.BK	TOOL, HAND BLACK	1
▲ 2	150913	FITTING, BRS QDC PF04 SER60	1
▲ 3	150606	FITTING, BRS STR PF04 HEX NIP	2
▲ 4	200905	LEVER, K- VALVE W/PIN	1
▲ 5	210210	●VALVE, FLOW CONTROL 04PF	1
▲ 6	190600	KIT, K- VALVE REPAIR	1

REF	PART #	DESCRIPTION	QTY.
▲ 7	140609	PIN, ROLL 0.187D X 0.56L	1
▲ 8	150403	FITTING, BRS E45 PF04/PF04	1
▲ 9	200992	FITTING, BRS STR PF02 SWIVEL	1
▲ 10	200996	FILTER, SCREEN 100MESH	1
▲ 11	200965	●FITTING, BRS TIP, 8002 T- JET	1
▲ 12	200994	CAP, NOZZLE SPRAY (8002)	1

HAND TOOL, CREVICE, 3 in / 76 mm

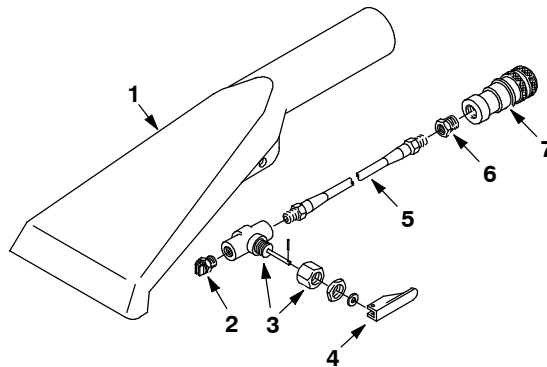

REF	PART #	DESCRIPTION	QTY.
▽	200517	●TOOL, CREVICE LP/HP SER 60	1
▲ 1	200436.BK	TOOL, CREVICE BLACK	1
▲ 2	200975	●FITTING, BRS TIP #5002 1/8V- JET	1
▲ 3	210014	●VALVE, TOGGLE 02PF W/NUT	1

REF	PART #	DESCRIPTION	QTY.
▲ 4	210020	POSITIONER, VALVE HANDLE	1
▲ 5	160106	HOSE, SOLUTION CREVICE TOOL	1
▲ 6	150100	FITTING, BRS STR PM04/PF02	1
▲ 7	150913	FITTING, BRS QDC PF04 SER 60	1

▽ ASSEMBLY

▲ INCLUDED IN ASSEMBLY

● RECOMMENDED STOCK ITEMS

HAND TOOL, UPHOLSTERY, LOW PRESSURE

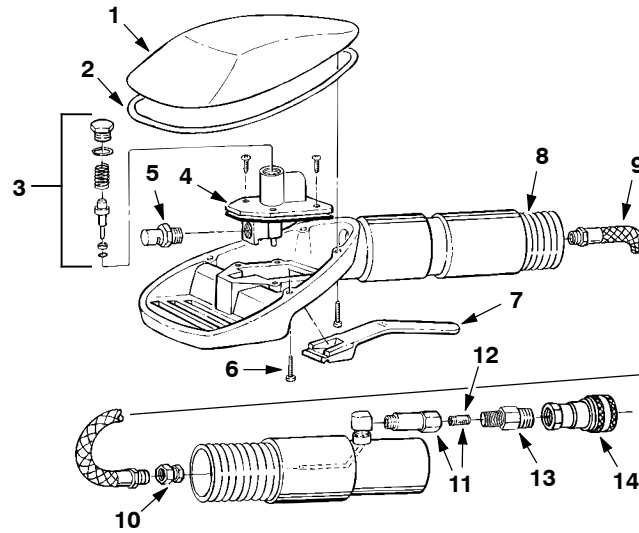

REF	PART #	DESCRIPTION	QTY.
▽	200540	●TOOL, UPHOLSTERY LP SER 60	1
▲ 1	200845	COVER, UPHOLSTERY TOOL	1
▲ 2	200843	GASKET, COVER	1
▲ 3	190631	●KIT, SERVICE LP UPHOLSTERY	1
▲ 4	210226	●VALVE, WATER/SOL 120VAC LP	1
▲ 5	200991	●FITTING, SS TIP 1/8K- JET	1
▲ 6	200838	SCREW, #06- 32 X 0.75	4
▲ 7	200840	TRIGGER, UPHOLSTERY TOOL	1

REF	PART #	DESCRIPTION	QTY.
▲ 8	200844	●HOSE, VAC UPHOLSTERY TOOL W/O CUFFS	1
▲ 9	200837	●HOSE, UPHOLSTERY TOOL	1
▲ 10	200848	FITTING, BRASS (3 PCS)	1
▲ 11	200842	FILTER, INLINE COMPLETE	1
▲ 12	200841	SCREEN ONLY, INLINE FILTER	1
▲ 13	150606	FITTING, BRS STR PM04 HEX NIP	1
▲ 14	150913	●FITTING , BRS QDC PF04 SER 60	1

▽ ASSEMBLY

▲ INCLUDED IN ASSEMBLY

● RECOMMENDED STOCK ITEMS

OPTIONS

HOSES, SOLUTION AND VACUUM

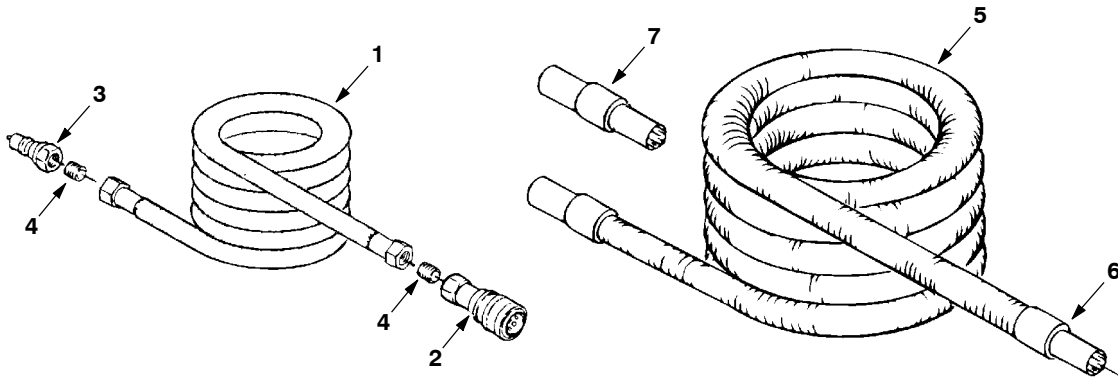

REF	PART #	DESCRIPTION	QTY.
▽ 1	160185	HOSE, SOLUTION 3/8X4.6M/15' (OPTIONAL)	1
	160186	HOSE, SOLUTION 3/8X7.6M/25' (STANDARD)	1
	160187	HOSE, SOLUTION 3/8X15.2M/50' (OPTIONAL)	1
▲ 2	150913	●FITTING, BRS, QDC, PF04, SER60	1
▲ 3	150933	FITTING, BRS, QDC, PM04, SER60	1
▲ 4	150615	FITTING, BRS, STR, PM04, CLOSE, T	2

REF	PART #	DESCRIPTION	QTY.
▽ 5	160400	HOSE, VACUUM 1- 1/2X4.6M/15' (OPTIONAL)	1
	160401	HOSE, VACUUM 1- 1/2X7.6M/25' (STANDARD)	1
	160402	HOSE, VACUUM 1- 1/2X15.2M/50' (OPTIONAL)	1
▲ 6	160430	●CUFF, HOSE 1- 1/2"	2
7	12694	●FITTING, PLSTC, STR, BM24/BM24	1
N/S	220040	●BAG, HOSE W/DRAW STRING (OPTIONAL)	1

▽ ASSEMBLY

▲ INCLUDED IN ASSEMBLY

● RECOMMENDED STOCK ITEMS

PUMP-UP CARPET SPRAYER

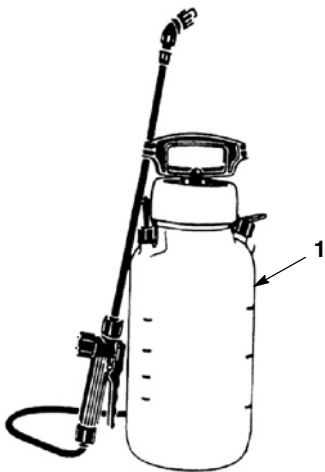

REF	PART #	DESCRIPTION	QTY.
1	605848	●SPRAYER 2GAL PUMPUP HEAVY DUTY	1

● RECOMMENDED STOCK ITEMS