



WARRANTY



MANUAL v1.0

DUAL CHANNEL TUBE OVERDRIVE / PREAMP



Congratulations on your purchase and thank you for supporting us!

INTRODUCTION

MAGNEZIUM™ is a two-channel preamp inspired by the sound of the highly coveted "Magna" Super 59 amp, crafted with input from Billy F. Gibbons (hence the "Z" in the name).

The pedal features two fully independent channels – for low and high gain. The low-gain channel produces a rich bottom end, paired with a Voxy chime at lower gain settings. The midrange comes forward as you turn up the gain, delivering more colored and tastefully saturated tones. The high-gain channel is perfect for those classic southern rock tones. Cranking the gain past noon will take you firmly into harmonically rich ZZ Top riffing territory. The MAGNEZIUM™ has an all-tube signal path and true bypass switching.

All Tubesteeper pedals are warranted to be free from defects in parts and craftsmanship for 5 years from the original date of purchase. The external hardware, such as pots, switches and jacks are warranted to be free from defects for a period of 1 year from the date of purchase. The tubes are covered for a period of 30 days from receipt of the pedal.

EXCLUSIONS:

- Damage caused by accident, abuse, modification, improper use.
- Cosmetic wear and tear of the enclosure and external hardware.
- Shipping costs.

The Tubesteeper will repair or replace, at our discretion, the product under the warranty at no cost to the original owner. For any warranty or repair inquiries, please contact support@tubesteeper.com. Returns are accepted within 7 days from the date of receiving your order. To qualify for return the product has to be in "new" condition, in the original packaging and perfect working order.

Tubesteeper reserves the right to make changes and improvements in designs & dimensions without notice.

BLOCK DIAGRAM

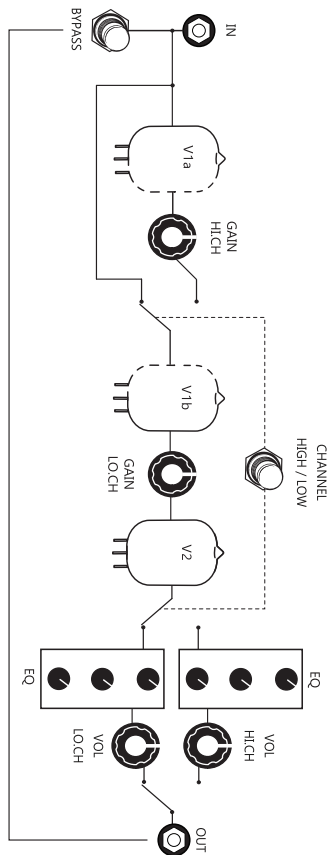

CAUTION! RISK OF ELECTRIC SHOCK.
DO NOT OPEN THE ENCLOSURE.

CONTROLS

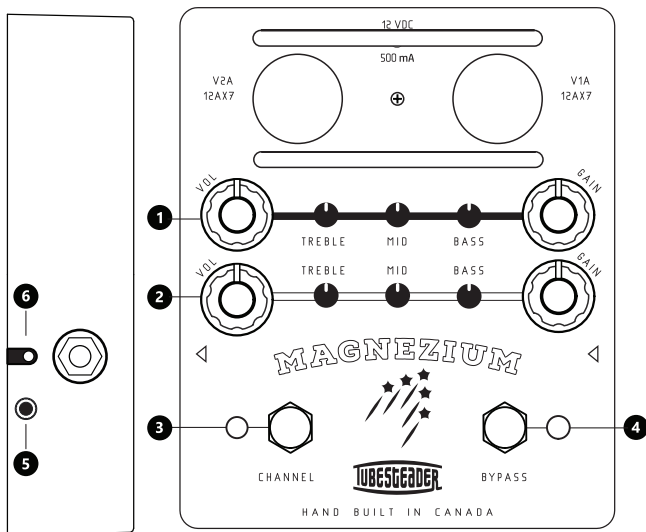

- 1 **HI-GAIN CHANNEL CONTROLS** ----- marked in black
- 2 **LOW-GAIN CHANNEL CONTROLS** ----- marked in white
- 3 **CHANNEL** ----- Hi-gain / Low-gain channel selection footswitch
- 4 **BYPASS** ----- True bypass footswitch with a status light
- 5 **EXT.SW** ----- 3.5mm (1/8") jack for external channel switching
- 6 **OUT.LVL** --- attenuated output mode / full output mode switch

FEATURES

MAGNEZIUM™ features two fully independent channels – for low and high gain – and has the option of external switching between them via the 3.5mm side-mounted jack. A simple latching external switch that shunts the tip to the ground will work.

It's equipped with a pair of 12AX7 tubes operating at full 250VDC – all converted from a simple 12VDC input. You can swap these AX7's with equivalent 9-pin preamp tubes from other brands to create different tones and breakup characteristics.

When powering up from a cold state, please allow the preamp to warm-up a few minutes before playing. The tubes run warm to the touch under normal operation.

A toggle switch on the side of the pedal offers two options: a higher output for direct connection to a power amp and an attenuated output with a treble cut for connection to the front of the amp.

MAGNEZIUM™ comes with a universal SMPS power supply that can be used in any country.

To power the pedal, you can either use the power supply provided with the Magnezium or use a pedalboard power supply capable of providing 500mA at 12VDC from a single outlet, such as CIOKS DC7.

Another option is to use a current doubler adapter, such as the Voodoo Lab part# PPAP, which combines the current capacity of two 12V@250mA outlets to create a single 12V@500mA outlet. Be careful not to supply more than 12VDC as doing so can damage the pedal.

POWER

CONNECT THE MAGNEZIUM:

- 1 As an overdrive pedal into the front end of an amplifier. Set the amplifier clean and with a flat EQ – let the Magnezium (with the OUT LVL switch engaged) take over, adding its unique gain structure and British-style EQ. You can run boosts into it to push the tubes even harder or overdrive pedals to further shape the tone...have fun and experiment!
- 2 Run directly into a power amplifier. Turn up the volume to give any power amp enough level to become an authentic "Magna"-flavored tone monster.
- 3 Into an amplifier's FX loop return. Bypass your amp's front end by plugging your guitar into the Magnezium and running the output into its FX loop return. Not all loops are created equal so the results may depend on the particular amp.
- 4 Into IR software or direct to a console/interface. Keep your FOH engineer happy by giving them consistent sound and level night after night, or appease the neighbors by keeping the volume down when practicing after dark. If using the Magnezium in this way, we recommend using an IR/Cabinet simulation for a more true-to-life amp sound.

Vacuum Tubes: ECC83/12AX7 x 2

Power: 12VDC @ 500mA, power adapter supplied

Power connector: barrel 2.1mm, center negative 

Enclosure: Die-cast aluminum

Size: 4.7" x 5.7" (120mm x 145mm)

Height: 2.75" (70mm) including tube protectors

Weight: 1.6 lbs (800 gr.)

CONNECTIVITY

SPECIFICATIONS