

TP1430C

**SINGLE PORT HIGH-POWER MULTI-CHEMISTRY
CHARGER/DISCHARGER/CYCLER/BALANCING SYSTEM**



INSTRUCTION/OPERATION MANUAL

THUNDER  POWER RC

www.ThunderPowerRC.com

TABLE OF CONTENTS

NOTICE, WARNING, AND CAUTION.....	3
NOTICE	3
WARNING	4
CAUTION.....	4
BOX CONTENTS	4
FEATURES	5
SPECIFICATIONS	7
INPUT POWER SOURCE AND CONNECTION.....	6
Input Current Max.....	6
Input Power Low Voltage Cutoff.....	6
Input Power Source Connection	6
INPUT AND OUTPUT POWER	7
BATTERY CONNECTIONS	7
BALANCER CONNECTIONS (for LiPo/Lilon/LiFe batteries)	8
OPERATING INFO.....	9
Button Functions.....	9
+/- buttons.....	9
PORT button.....	Error! Bookmark not defined.
MODE button	9
ENTER button	9
CHARGE MODE.....	10
Memory Profiles.....	10
Battery Chemistry Type.....	10
Battery Cell Count	11
Battery Capacity	11
Charge Current Rate.....	11
Balancing ON/OFF (for LiPo/Lilon/LiFe batteries).....	12
Delta Peak Sensitivity (for NiCd/NiMH batteries)	13
Charging the Battery	13
Charging LiPo/Lilon/LiFe (A123) Batteries	13
Data Monitoring During Charging	14
Charging Complete/End	15
Charging LiPo Batteries for use in Series on Separate Ports.....	Error! Bookmark not defined.
Charging Split LiPo Batteries up to 16S on Separate Ports	Error! Bookmark not defined.
DISCHARGE MODE	15
Discharge Current Rate	16
Discharge Voltage Cutoff.....	17
Discharging the Battery.....	17
Data Monitoring During Discharging.....	17
Discharging Complete/End.....	18
Cooling Fans During/After Discharge	18

CYCLE MODE	18
Cycle Order	18
Cycle Number	18
Cycling the Battery	19
Data Monitoring During Cycling	19
Cycling Complete/End	19
STORAGE MODE	20
Storage Charging/Discharging the Battery	20
Data Monitoring During the Storage Process	20
Storage Complete/End	21
SETTING DATA MODE	21
Charge End Voltage	21
Power Distribution	Error! Bookmark not defined.
Input Power LVC/Input Current Max	22
Cycle Pause Time	22
Charge Capacity Limit	22
Safety Timer	23
Temperature Cutoff	23
Key Beep	23
End Beep Duration	23
Temperature Unit	23
DATA VIEW MODE	24
Battery Internal Resistance	24
To Measure Battery Internal Resistance	25
To Measure Individual Cell Internal Resistance	26
Charge/Discharge Mode Data	26
Cycle Charge/Discharge Capacity Data	26
Peak Voltage and Discharge Average Voltage Data	26
Individual Cell Voltage Data (for LiPo/Lilon/LiFe Batteries)	27
Real-Time Input Voltage and Output Voltage Data	27
Internal Temperature Data	27
ERROR MESSAGES AND TROUBLESHOOTING	27
FIRMWARE UPDATES	28
WARRANTY, SUPPORT, AND SERVICE	29

NOTICE

All instructions, warranties, and other collateral documents are subject to change at the sole discretion of Advance Energy, Inc. dba Thunder Power RC. For up-to-date product literature, visit www.ThunderPowerRC.com or call 702-228-8883.

WARNING

Read the ENTIRE instruction manual to become familiar with the features/functions of the charger before operating. NEVER LEAVE THE CHARGER UNATTENDED DURING USE. Failure to observe/operate the charger properly can cause damage to the charger, battery, personal property and/or cause serious injury.

CAUTION

Attempting to charge batteries different than those specified in this manual can result in excessive heat and other related product malfunctions, which can lead to property damage and/or injury. Please contact Thunder Power RC (TPRC) or an authorized retailer with compatibility questions.

As TPRC has no control over use, setup, final assembly, modification or misuse, no liability shall be assumed nor accepted for any resulting damage or injury. By the act of use, setup or assembly, the user accepts all resulting liability.

If you as the Purchaser or user are not prepared to accept the liability associated with the use of this Product, you are advised to return this Product immediately in new and unused condition to the place of purchase.

BOX CONTENTS



FEATURES

- Powerful all-in-one charger, discharger and cyclers system with built-in LiPo/Lilon/LiFe (A123) cell balancer that offers maximum safety, performance and easy-to-see individual cell voltages
- The included balance connector adapter board allows the built-in balancer to be used with 2-14S Thunder Power-compatible balance connectors as well as the JST-XH balance connectors found on many other brands of batteries. This powerful single port design charges, discharges and cycle's 1-14S LiPo/Lilon/LiFe (A123), 1-40 cell NiCd/NiMH or 6-48V Pb (lead-acid) batteries.
- Up to 1000 watts of total power with selectable charge current between 0.2 amps up to 30 amps for ultra-fast charging
- The perfect choice for safe and ultra-fast charging at rates of up to 6C and beyond for the latest-generation LiPo batteries
- Advanced Storage Mode function for LiPo/Lilon/LiFe (A123) batteries will automatically charge or discharge as needed to achieve storage level voltage
- 12 user-programmable memories plus built-in live data monitoring with internal resistance measurement, battery voltage, input voltage, temperature and more
- Fully-adjustable charge capacity limit, per cell end voltage and low voltage cutoff settings for all chemistries to maximize safety, charge and discharge performance
- Durable and compact aluminum case with dual computer-controlled cooling fans and a large, easy-to-read LCD screen
- Wide input voltage range from 12.0-36.0V for higher efficiency and power output when using 24.0-36.0V power supplies
- Adjustable input power current limiting and low voltage cutoff settings to maximize performance while also protecting the charger and input power supply
- Future firmware updates can be downloaded for free from www.ThunderPowerRC.com when new features, battery chemistry and other updates are made available and are easily uploaded to the charger using a standard mini USB cable
- Full industry-leading warranty and support from Thunder Power RC

SPECIFICATIONS

Type: Multi-Chemistry DC Charger/Discharger/Cycler with Integrated Balancers

Battery Cell Counts/Types: 1-14S LiPo/Lilon/LiFe (A123), 1-24 cell NiCd/NiMH and 6-30V Pb (lead-acid)

Balancer: Integrated for 2-14S LiPo/Lilon/LiFe (A123) with balance connector adapter board for Thunder Power and JST-XH connectors

Input Power: 12.0-36.0V DC (40 amps max)

Charge Power: 1000 watts max w/28.0-36.0V input (see later in this manual for additional information regarding input and output power)

Charge Current 0.2 to 30 amps in 0.01 amp increments

Charge Voltage: 50% storage and adjustable end voltage for LiPo/Lilon/LiFe (A123), adjustable delta peak sensitivity and end voltage for NiCd/NiMH and end voltage for Pb (Lead Acid)

Discharge Power: 100 watts max

Discharge Current: 0.2 to 15 amps in 0.01 amp increments

Discharge Voltage: Adjustable low voltage cutoff for LiPo/LiIon/LiFe (A123), NiCd/NiMH and Pb (lead-acid)

Cycles: 1 to 15 times

Memories: 12 user-programmable

Firmware: User-updatable using USB

INPUT POWER SOURCE AND CONNECTION

The TP1430C (charger) is designed and built to be powered from a 12.0-36.0V DC power source. This can include a single 12V Pb/lead-acid battery, three 12V Pb/lead-acid batteries connected in series for up to 36V or a quality AC to DC power supply with stable 12.0-36.0V DC output.

Input Current Max

The maximum input current can be set from 10.0-40.0A in order to prevent damage to the power source and/or charger. This means you can limit the maximum current the charger can pull from the power source per the maximum capabilities of the source as needed. For example, if you are using a power supply that is capable of outputting 25.0A max you should adjust the Input Current MAX setting to 25.0A to ensure the charger is not able to pull more than 25.0A from the power supply. You can adjust this setting in the charger by powering it on and pressing the MODE button once to scroll to the Setting Data Mode menu, then press the + or – buttons to scroll to the appropriate menu and adjust the setting accordingly. Or, in order to obtain maximum output power (per input voltage) for charging, you must use a power supply capable of delivering up to 40.0A.

Input Power Low Voltage Cutoff

You can also set the Input Power LVC (Low Voltage Cutoff). This is the input voltage at which the charger will stop charging/discharging in order to prevent overloading/over-discharging the input power source. This is particularly beneficial when charging from a 12V Pb/lead-acid car battery as it allows you to maintain enough voltage/power in the battery to still start the car after using the charger.

You can adjust this setting in the charger by pressing the MODE button once to scroll to the Setting Data (Settings) menu, then press the + or – buttons to scroll to the appropriate menu and adjust the setting accordingly. We recommend setting this value to between 12.0V and 13.0V for typical use, or in the case that you will be loading the input power source considerably (so the voltage will drop more significantly under load even though there is still sufficient capacity remaining in the 12V battery for example) you can set this as low as 12.0V. However, keep in mind that dropping the voltage under load to as a low as 12.0V (or even 13.0V under some loads) could result in discharging a 12V battery input power source low enough that it will not start the car when needed.

Input Power Source Connection

The input power leads for the charger are equipped with 4mm bullet connectors compatible with most typical female 'banana plug' receptacles. You can connect these directly to the outputs of many AC to DC power supplies, or you can also connect them to the included alligator clips for more convenient connection to Pb/lead-acid batteries. However, especially when charging at or near maximum input/output power levels, you must ensure the bullet connectors/alligator clips are making excellent contact with the power source in order to minimize resistance and prevent voltage/power loss/damage.

After connecting the charger to the input power source with proper polarity the charger will power on accordingly. At this point you will briefly see the 'Welcome' screen indicating the charger model and the version of firmware currently installed in the charger.

Please also note that in some cases if the connection to the input power source is not 'clean' the welcome screen may not show and instead only part of the default Charge Mode screen will show. This will typically happen when connecting the charger to a power source that is already 'on' so we suggest powering down the source before connecting the charger. Also, if this occurs simply disconnect the charger from the power source, then re-connect ensuring that you achieve a solid/clean connection during the process.

INPUT AND OUTPUT POWER

The charger will automatically adjust the max output power level available based on the input voltage, current, output voltage, etc. and at no time can the input current exceed 40.0A max. As a result you can obtain higher/maximum output power when using higher voltage power sources that provide 24.0-36.0V. However, it is still possible to obtain relatively high levels of output power using more common 12.0-15.0V power sources.

Here also is a quick way to help determine the approximate amount of input power your chosen power source can supply:

Input Voltage (under load) (V) x Input Current (A) = Input Power (W)

For example:

$$\begin{aligned} 12V \times 25A &= 300W \\ 12V \times 40A &= 480W \end{aligned}$$

$$\begin{aligned} 24V \times 25A &= 600W \\ 27V \times 40A &= 1080W \end{aligned}$$

The input power level will dictate the charger's output power level capability in total based on charger efficiency (typically ~85-93% depending on input/output voltage). And in turn the output power level capability will dictate the maximum charge current/voltage capability accordingly.

Please see the chart provided separately for a quick reference of the maximum output power levels/charge current for LiPo batteries based on the listed input voltage and current (and please note that these values are approximate and may vary slightly +/- depending on input voltage of the power source under load, ambient temperatures, state of charge/voltage level of the battery being charged, etc.).

Also, for those interested in achieving maximum output power (1000W total) we recommend using a 27.0-28.0V, 35-40A power supply for maximum efficiency (especially when charging multiple 6S 22.2V LiPo batteries for example). One such power supply we've used with excellent success is the IOTA Engineering DLS-27-40. With a typical output voltage of 27.2V and the capability to deliver up to 40A, this power supply can deliver upwards of 1100W to the charger allowing for maximum output (1000W) with some headroom to spare (also works well with two TP1430C chargers running at high power levels up to ~500W each).

BATTERY CONNECTIONS

The charger is equipped with typical female 'banana plug' receptacles that are compatible with most male banana plugs and 4mm bullet connectors. We suggest using gold 4mm bullet connectors, like those found on the included battery connection leads, especially when charging at rates above 5 amps.

You can also install the connector of your choice on the included battery connection leads or you can purchase pre-made 'charge leads' equipped with banana or 4mm bullet connectors and connectors compatible with the connectors installed on the batteries you will be charging/discharging. Please note that wire leads that are too long or not large enough gauge for the applicable charge/discharge current will damage the charger and/or result in errors in battery charging/discharging. Therefore we recommend keeping the length of the wire leads as short as possible (preferably 12"/305mm long max). We also recommend using 10 to 14 AWG wire leads when charging at rates 10 amps and higher, minimum 16 AWG at rates up to 10 amps and minimum 18 AWG at rates up to 5 amps.

Please also be certain to connect all batteries with the proper polarity as marked on the faceplate label and further identified by the colored rings around the banana plug receptacles (red is +/positive and black is -/negative). And in the event that you do connect the battery with incorrect polarity the error message 'Battery Reverse Polarity' (or 'Battery Polarity Inversion' in earlier version firmware) will show on the screen. However, in order to prevent all possibility of damage to the charger and/or battery you should always exercise care to ensure proper polarity when connecting batteries.

Also, DO NOT connect the battery to the charger when the charger is powered off. The charger should always be powered on before connecting the battery.

BALANCER CONNECTIONS (for LiPo/Lilon/LiFe batteries)

The TP1430C is equipped with built-in balancer for LiPo/Lilon/LiFe (A123) cells/batteries. The balancer is marked on the faceplate label and **you must ALWAYS use the balancer when charging LiPo/Lilon/LiFe batteries for maximum safety and battery performance/longevity.** The balancer works in conjunction with the charger **to prevent over-charging that can result in fire causing damage and/or personal injury.** It does this by ensuring the voltages of cells within LiPo/Lilon/LiFe batteries are closely balanced by discharging the higher voltage cells to closely match the lower voltage cell(s) in the battery. This prevents over-charging any cell(s) that may have a higher voltage during the charge process, or, in the event that the balancer cannot balance the cell(s) in time to prevent exceeding the 'CHG End Voltage' setting (for any cell), the charger will automatically reduce the charge current rate and/or end the charge process entirely as needed.

Please also note that due to the high-power charging capabilities of the TP1430C, it is not designed to charge through the balance connectors/leads of LiPo/Lilon/LiFe batteries. These connectors/leads are typically limited to maximum charge/discharge rates of only 2-4 amps versus the up to 20 amp charge rate capability of the TP1430C. As a result you MUST connect the main power AND balance connector leads to the charger in order to charge through the main power and balance through the balance connector leads accordingly.

There is one 8-pin and one 9-pin Thunder Power type connector for the balancer located on the side of the charger. When viewing each connector straight on (with the top/face of the charger pointed upwards) the main ground/negative (-) connector (pin) is located on the far left while the positive (+) connector is located on the far right. In order to prevent any issues with connection location, polarity, or fatigue of the connection between the 8 and 9-pin connectors and the charger board internally, you must always use the included balance connector adapter board.

To use the included balance connector adapter board simply insert the male 8 and 9-pin connectors into the female 8 and 9-pin connectors on the side of the charger. The connectors are 'keyed' to

prevent reverse polarity connection, and each balance connector adapter board is equipped with balance connectors compatible with all 2S 7.4V to 14S 51.8V LiPo/LiIon/LiFe batteries equipped with Thunder Power and JST-XH balance connectors. And in the event that you must connect batteries that are not equipped with TP or JST-XH balance connectors, there are additional balance connector adapter leads (i.e. – TP to JST-EH, etc.) available from many sources.



After connecting the balance connector adapter board to the charger/balancer you can connect the balance connector from the battery to the appropriate mating connector, ensuring proper keying of the connectors and polarity on the board accordingly. And please note that unless you are using the correct adapters/connections to charge multiple batteries in series and/or parallel (contact Thunder Power RC directly for more information on series/parallel charging if needed) you must NOT connect more than one battery to the balance connector adapter board. If you connect multiple batteries incorrectly or connect one battery with incorrect polarity it is possible to damage the traces and/or the pins/connectors on the balance connector adapter board. Such damage is not covered under warranty.

OPERATING INFO

Button Functions

+/- buttons

The +/- buttons allow you to scroll up/down through menus before and during charging/discharging. These buttons also allow you to change values/settings for options after they have been selected (typically when flashing after pressing the ENTER button).

MODE button

The MODE button functions only before and not during charging/discharging. Pressing the MODE button will allow you to scroll between the three available modes:

Charge/Discharge/Cycle/Storage Modes
Setting Data Mode
Data View Mode

ENTER button

The ENTER button allows you to select and validate values/settings for options that can be changed (using the +/- buttons to change) before and during charging/discharging. Pressing and holding the ENTER button also allows you to start and stop charging/discharging.

CHARGE MODE

After powering on the charger properly the first mode always shown by default is the 'Charge Mode'. This is the mode that allows you to set the memory profile number, battery chemistry type, number of cells, battery capacity limit, charge current rate, balancing on/off for LiPo/Lilon/Life or the delta peak value for NiCd/NiMH. **It's also important to note that all of these settings must be set in this mode/screen before changing to the discharge, cycle or storage modes (these settings cannot be changed/set in those modes).**

Here is a quick reference of what the Charge Mode screen displays:

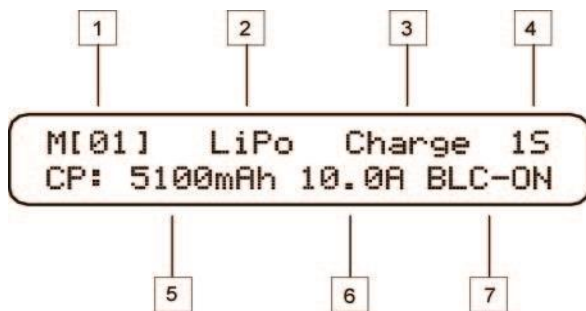

- 1) Memory profile number
- 2) Battery chemistry type
- 3) Mode (charge, discharge, cycle, storage)
- 4) Number of cells (in series)
- 5) Battery capacity
- 6) Current rate
- 7) Balancing ON/OFF for LiPo/Lilon/LiFe or Delta Peak Sensitivity value for NiCd/NiMH

Memory Profiles

You can set a total of 12 memory profiles. This is a convenient feature as it allows you to set the typical charge, discharge, cycle, and storage mode profiles for specific batteries to save you time versus having to always change the settings when charging/discharging different configurations and chemistries of batteries.

To scroll through the available memory profiles, while on the Charge Mode screen simply press the ENTER button once. The memory profile number will begin to flash and you can use the +/- buttons to scroll through the profiles accordingly.

Battery Chemistry Type

The TP1430C is capable of charging/discharging LiPo, Lilon, LiFe (A123), NiCd, NiMH and Pb (lead-acid) batteries. **Each of these chemistries/types of batteries is charged in a different way and the correct chemistry/type must be selected in order for the charger to charge/discharge safely. Failure to select the correct chemistry/type and settings per the battery being charged/discharged can result in damage to the battery or fire causing damage and/or personal injury. If you are unsure of the battery chemistry/type, and the correct settings that must be used for safe and correct charging/discharging, DO NOT attempt to charge/discharge the battery. Instead, please contact the manufacturer of the battery to verify the information prior to charging/discharging the battery.**

To select the correct battery chemistry/type, while on the Charge Mode screen simply press the ENTER button twice. The battery chemistry/type will begin to flash and you can use the +/- buttons to scroll through them accordingly. After selecting the correct chemistry/type you can press the ENTER

button to select the other adjustable values, or wait approximately 5 seconds until the chemistry/type stops flashing to begin the charge process or to scroll through the other modes (discharge, cycle, and storage).

Battery Cell Count

The TP1430C is capable of charging/discharging 1S (3.7V) to 14S (51.8V) LiPo, Lilon and LiFe (A123) batteries, as well as 1-40 cell NiCd and NiMH along with 1S (2V) to 24S (48V) Pb (lead-acid) batteries. **After selecting the correct battery chemistry/type you MUST select the correct cell count for the battery you will be charging/discharging. Failure to select the correct cell count per the battery being charged/discharged can result in damage to the battery or fire causing damage and/or personal injury. If you are unsure of the battery cell count DO NOT attempt to charge/discharge the battery. Instead, please contact the manufacturer of the battery to verify the information prior to charging/discharging the battery.**

To select the correct battery cell count, while on the Charge Mode screen simply press the ENTER button three times. The battery cell count will begin to flash and you can use the +/- buttons to increase/decrease the cell count accordingly. After selecting the correct cell count you can press the ENTER button to select the other adjustable values, or wait approximately 5 seconds until the cell count stops flashing to begin the charge process or to scroll through the other modes.

Battery Capacity

For added safety and ease of use, the TP1430C features a function that allows you to set the battery capacity. This function allows you to enter the capacity of the battery you'll be charging so the charger can automatically set a 1C (1 x Capacity) charge rate. In general most supported battery chemistries/types can be charged safely and successfully at a 1C rate, so this feature makes for the easiest possible setting and use especially if you are not confident in taking advantage of and/or aware of the max charge rate capability of the battery you'll be charging.

ALWAYS set the battery capacity correctly. To set the correct battery capacity, while on the Charge Mode screen simply press the ENTER button four times. The battery capacity will begin to flash and you can use the +/- buttons to increase/decrease the capacity accordingly. After setting the correct capacity you can press the ENTER button to select the other adjustable values, or wait approximately 5 seconds until the battery capacity stops flashing to begin the charge process or to scroll through the other modes.

Charge Current Rate

After setting the battery capacity limit correctly, the charger will automatically set the charge current rate to 1C. In the case of a 5000mAh battery, it will set the charge current to 5.00A. And again, in general most supported battery chemistries/types can be charged safely and successfully at a 1C rate so we suggest charging at the 1C rate especially if you are not confident in taking advantage of and/or aware of the max charge rate capability of the battery you'll be charging.

Or, if you are interested in charging at a rate higher (or lower) than 1C you can adjust the charge current rate accordingly. **However, it is important to note that if you charge at a current rate that is too high it can result in damage to the battery or even fire causing damage and/or personal injury. If you are unsure of the maximum safe charge rate of the battery, DO NOT charge at a rate higher than 1C or please contact the manufacturer of the battery to obtain the correct maximum charge rate.**

To set the charge current rate: while on the Charge Mode screen simply press the ENTER button five times. The charge current rate will begin to flash and you can use the +/- buttons to increase/decrease the current rate accordingly. After setting the charge current rate you can press the ENTER button to select the other adjustable values, or wait approximately 5 seconds until the current rate stops flashing to begin the charge process or to scroll through the other modes.

Also, before starting the charge process, the maximum charge current that can be set is automatically calculated by the charger based on the voltage of the input power source and the estimated voltage of the battery being charged based on the cell count you have selected. This is calculated using the discharged voltage of the battery (i.e. ~3.3V per cell for LiPo batteries), but will be no higher than 30A as this is the maximum charge current.

If you have set the charge current rate to the maximum rate possible, after starting the charge process the charger will automatically adjust the current rate, per the actual voltage of the battery at any given time, to maintain (and not exceed) the maximum output power level (wattage). For example, in the case of charging a 6S 22.2V 5000mAh LiPo battery and when using a 27.0-36.0V/35-40A power supply for maximum input/output power, before the charge process has started you will be able to set the charge current rate to 30.0A max. However, if the battery is currently at more than 20.0V the charger will then adjust the current rate automatically between 30.0A and approximately 15.8A as needed to ensure it does not exceed the 1000W maximum output power level. And when the battery nears/reaches the end of the Constant Current (CC) phase of the charge around 25.2V (4.2V per cell) the current rate will reduce accordingly throughout the Constant Voltage (CV) phase of the charge process and until the charge is complete.

Also, after the charge process has started (and if you have not already set the charge current rate to the maximum rate possible) you can actually increase the charge current rate by up to 25% (i.e. – from 10.0A to 12.5A) or to the maximum charge current rate possible based on the actual voltage of the battery and output power level of the charger; whichever comes first. To do this, simply press the ENTER button once immediately (or any time) after the charge process has been started (and the 'Battery Check Please Wait...' check is complete) and the current rate will begin to flash. You can then use the + button to increase (or the – button to decrease) the current rate accordingly.

Please also see the chart provided separately for a quick reference of the maximum output power levels/charge current rate settings for LiPo batteries based on the listed input voltage and current (please note that these values are approximate and may vary slightly +/-).

Balancing ON/OFF (for LiPo/Lilon/LiFe batteries)

As noted in further detail in the **BALANCER CONNECTIONS** section of this manual, the TP1430C is equipped with built-in balancer for LiPo/Lilon/LiFe (A123) cells/batteries and **you must ALWAYS use the balancer when charging LiPo/Lilon/LiFe batteries for maximum safety and battery performance/longevity.**

The balancer can also further ensure that you've set the cell count correctly, and as a result we strongly recommend keeping the balancing turned ON at all times. Please also note that when balancing is turned ON you MUST connect the balance connector of the battery to the balance connector adapter board (which must be connected to the balancer/charger) BEFORE you start the charge process otherwise you'll encounter a Battery Type Error warning.

However, if you understand the associated risks, accept full responsibility, and choose to charge LiPo/Lilon/LiFe batteries without balancing/using the built-in balancers, it is possible to turn the balancing OFF.

To turn the balancing ON/OFF, while on the Charge Mode screen simply press the ENTER button six times. The balancing status will begin to flash and you can use the +/- buttons to turn it ON or OFF. After turning the balancing ON or OFF you can press the ENTER button to select the other adjustable values, or wait approximately 5 seconds until the status stops flashing to begin the charge process or to scroll through the other modes.

Delta Peak Sensitivity (for NiCd/NiMH batteries)

When the charger has been set to charge NiCd or NiMH chemistry/type batteries you can also set the delta peak sensitivity value. This is the difference in voltage when the NiCd/NiMH battery reaches peak voltage/fully charged voltage and is used to complete/end charging of NiCd/NiMH batteries accordingly.

Generally speaking a higher delta peak sensitivity value will result in more charge or even potential over-charge, however, in many cases a slight amount of over-charge and the resulting warming of the cells/battery is desired to ensure the highest possible performance. Slightly warm NiCd/NiMH cells/batteries (approximately 5-15° Fahrenheit above ambient) are also a good indication that they are fully charged, however, it is recommended to use the lowest delta peak sensitivity value that allows the cells/battery to be fully charged and to not stop charging prematurely (typically referred to as 'false peaking').

NiCd cells/batteries typically require a higher delta peak sensitivity value (~10-20mV per cell) to reach full charge while NiMH batteries require a lower value (~1-10mV per cell). However, in the case of either chemistry the actual value that works best will depend on many factors including the capacity, condition and internal resistance (IR) of the cells/battery, IR of the charge leads/connectors, charge current rate, ambient temperature and more. As a result it is always suggested to start with a lower value and to increase the value accordingly as needed to achieve slight warming of the cells after the charge process had been completed/ended.

To adjust the delta peak sensitivity value, while on the Charge Mode screen simply press the ENTER button six times. The value will begin to flash and you can use the +/- buttons to increase or decrease the value accordingly. After setting the value per your preference you can press the ENTER button to select the other adjustable values, or wait approximately 5 seconds until the value stops flashing to begin the charge process or to scroll through the other modes.

Charging the Battery

After setting the correct battery chemistry type, cell count, capacity, and current, and connecting the battery to the charger properly, you are ready to begin charging. To begin charging simply press and HOLD the ENTER button for a few seconds (please also note that during charging you can press and hold the ENTER button to end the charge process).

From there the charger will check the battery while displaying the following screen:

A rectangular box with rounded corners containing the text "BATTERY CHECK PLEASE WAIT...". The text is centered and appears to be a screen display from a device.

If the battery is connected properly and the charger confirms that all other parameters are correct, charging will begin automatically.

Charging LiPo/Lilon/LiFe (A123) Batteries

When charging LiPo/Lilon/LiFe batteries, if the voltage of any cell (when balancing is ON) or all cells are too low (below ~3.3V) the charger may charge at a rate lower than the charge current rate set before the charge process began and until the voltage is considered safe/high enough to charge the battery normally. Or, if the voltages of all cells are OK the charger will increase the current until it reaches the appropriate charge current rate. And in either case charging will be in the Constant Current phase, as indicated by the 'CC' located in the middle of the upper line on the screen, until the cells reach approximately 4.20V.

At that point, and as long as cells are balanced within 0.03V (when balancing is ON), charging will switch to the Constant Voltage phase as indicated by the 'CV' that will show in place of 'CC'. Or, if any cell is imbalanced by more than 0.03V charging will instead switch from the Constant Current phase to the Extended Balance phase, as indicated by the EB that will show in place of CC/CV. This will allow the charger to adjust the charge current rate as needed to ensure the cells are balanced to within 0.03V (or closer) before the charge process is ended automatically.

Data Monitoring During Charging

Throughout (and after) the charge process you can view/monitor various data. On the main charging screen you will see the elapsed duration of the charge process, the capacity that's been 'charged' into the battery, the charge current rate and the voltage of the battery. You can also use the +/- buttons to switch between the various screens to see the available data.

For example, when charging a LiPo/Lilon/LiFe battery and on the charging screen simply press the + button once and you will see the individual cell voltages (when balancing is turned ON). **Please also note that while only the second (hundredths) place after the decimal is shown due to the space available on the screen (in order to show voltages for up to 8 cells on a single screen), the charger is measuring and calculating the voltages/balance by using to the third (thousandths) place. This means when you see a cell at 3.80V and another at 3.82V the cells are likely as close as 3.804V and 3.816V, but the values on the screen are being rounded up and down accordingly.**

If you press the + button a second time you'll again see the elapsed time, as well as the internal temperature of the charger and the peak voltage the battery has reached through the duration of the charge process so far. Then, pressing the + button a third time will show the elapsed time along with the input voltage from the power source. This can be particularly useful, especially when pushing the input power source near its limits and/or when using a 12V (or 24V) Pb/lead-acid battery, to ensure the voltage is not dropping too much when under load during the charging process. Please also note that while only the second (hundredths) place after the decimal is shown the charger is measuring and calculating the input voltage by using to the third (thousandths) place. This means the input voltage reading may appear to move up and down slightly, however, as long as it is not fluctuating by more than ~0.03V the input voltage/power is indeed smooth and stable.

When charging a NiCd/NiMH/Pb (lead-acid) battery, the first time you press the + button you will see the elapsed time along with the average voltage of the battery that would show after a discharge process has ended. Pressing the + button a second time will show the internal temperature of the charger and the peak voltage the battery reached during the charge process, while pressing the + button a third time will show the elapsed time along with the input voltage from the power source.

Prior to charging, please review the Charge End Voltage information under the SETTING DATA MODE section found later in this manual.

Charge Completion

Charging will end automatically when the battery capacity has been reached per delta peak (for NiCd/NiMH batteries) or when the appropriate per cell CHG (Charge) End Voltage has been reached (for LiPo/Lilon/LiFe and Pb batteries). When this occurs you will see the following screen:

BATTERY CHARGE
COMPLETE

From there you can press the ENTER button once to display the data from the charge process, as well as use the +/- buttons to scroll through other screens, including the screen that features the Battery IR function to check the Internal Resistance (IR) of the battery and/or individual cells by pressing the ENTER button (while on those screens). Or, on most other screens you can press the ENTER button to exit the charge process completely.

Charging LiPo Batteries in Series

The 1430C balance adapter board will allow you to charge up to two 7S batteries or any combination to make a maximum of 14S at one time. Example: Two 6S batteries, Insert the balance plugs from battery 1 in the first set of plugs marked 6S. Then insert the balance plugs from battery 2 in the second set of 6S plugs. The charger will now read this as a single 12S battery. Then you need to attach a battery series charge adapter wire to the main power wires of the battery. Always connect the negative wire from the charger directly to battery number one. Make sure you set the charger for the appropriate numbers of cells.

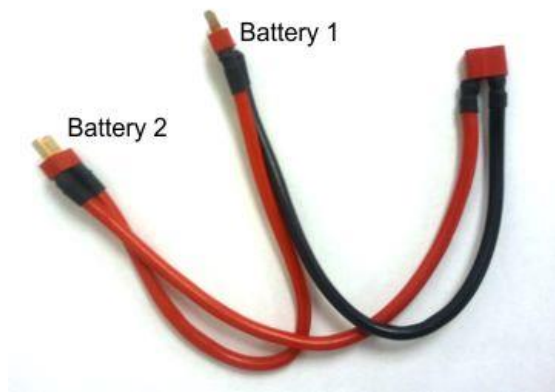
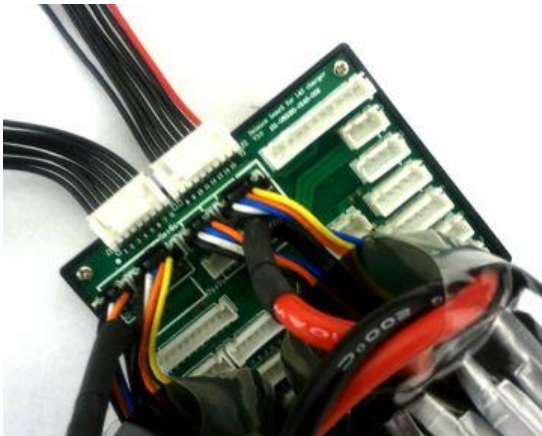

DISCHARGE MODE

The TP1430C is able to discharge batteries at rates up to 15.0A or 100W in order to check capacity or for other reasons as needed. . Please keep in mind that aside from the discharge current rate and per cell voltage cutoff that can be set in the Discharge Mode, the cell count must be set in the Charge Mode.

After setting the correct cell count in the Charge Mode, wait until none of the adjustable values are flashing, then press the + button once to enter the Discharge Mode.

Discharge Current Rate

In general most supported battery chemistries/types can be discharged safely and successfully at a 1C to 4C rate so we suggest discharging at no higher than these rates especially if you are not aware of the max discharge rate capability of the battery you'll be discharging. However, because the TP1430C is capable of discharging at rates up to 15A/100W, in many cases it will not be possible to discharge batteries even at the 1C rate, especially those above approximately 3S 11.1V 5000mAh.

However, especially in the case of lower capacity batteries for which you can exceed a 4C discharge rate, it is important to note that if you discharge at a current rate that is too high it can result in damage to the battery or even fire causing damage and/or personal injury. If you are unsure of the maximum safe discharge rate of the battery DO NOT discharge at a rate higher than 1C to 4C or contact the manufacturer of the battery to verify the battery's maximum discharge rate.

To set the discharge current rate, while on the Discharge Mode screen simply press the ENTER button once. The discharge current rate will begin to flash and you can use the +/- buttons to increase/decrease the current rate accordingly. After setting the discharge current rate you can press the ENTER button to select the other adjustable values, or wait approximately 5 seconds until the current rate stops flashing to begin the discharge process or to scroll through the other modes.

Also, before starting the discharge process, the maximum discharge current that can be set (if it is less than 15.0A) is automatically calculated by the charger based on the estimated voltage of the battery being discharged and the cell count you have selected (~3.6V per cell for LiPo batteries). So in most cases it is not possible to set the discharge current rate to the 15.0A max for cell counts more than 2S 7.4V for LiPo/LiIon/LiFe, and even if you do set the rate to 15.0A for higher cell batteries, it will exceed the maximum discharge power level (wattage) capabilities and the charger will reduce the rate accordingly after the discharge process has started.

After the discharge process has started you can increase the discharge current rate by up to 25% (i.e. – from 5.00A to 6.25A), or up to the maximum discharge current rate possible based on the actual voltage of the battery and power level of the charger for discharging; whichever comes first. To do this, simply press the ENTER button once immediately (or any time) after the discharge process has been started (and the 'Battery Check Please Wait...' check is complete) and the current rate will begin to flash. You can then use the + button to increase (or the – button to decrease) the current rate accordingly.

In the event that the discharge current rate and voltage of the battery being discharged, as well as the ambient temperature and internal temperature of charger, result in over-heating the charger (above ~130° F) during the discharge process, you will see the 'Over Temperature Please Wait...000'' warning including the current internal temperature of the charger. The charger will automatically pause the discharge until it cools to approximately 100° F, then it will resume the discharge automatically. Since the discharge current rate and voltage of the battery may not exceed the maximum discharge power rating of the charger, you may indeed need to reduce the discharge current rate in order to prevent the over temperature and pause.

Please also see the chart provided separately for a quick reference of the estimated maximum discharge power levels/discharge current rate settings for LiPo batteries based on the current rate and estimated voltage of the battery (and please note that these values are approximate and may vary slightly +/- depending on ambient temperatures, state of charge/voltage level of the battery being discharged, etc.).

Discharge Voltage Cutoff

You can set the per cell voltage cutoff that will end the discharge process automatically by using this setting. **However, especially in the case of LiPo/Lilon/LiFe batteries, it is important that you DO NOT over-discharge the batteries to a voltage that is too low as it can result in damage to the battery. If you are unsure of the safe discharge voltage cutoff for the battery, DO NOT discharge the battery or please contact the manufacturer of the battery to obtain the battery's low voltage cutoff level.**

Here also are some general suggestions of the per cell voltage cutoff to use for each battery chemistry/type to prevent over-discharge damage:

LiPo/Lilon	3.3-3.5V per cell when discharged at rates of 1-4C
LiFe	2.6-2.8V per cell when discharged at rates of 1-4C
NiCd/NiMH	0.9-1.0V per cell when discharged at rates of 1-4C
Pb/lead-acid	1.6-1.7V per cell when discharged at rates of 1-4C

Discharging the Battery

After setting the correct battery chemistry type and cell count in the Charge Mode and the correct discharge current rate and voltage cutoff in the Discharge Mode, connect the battery to the charger properly and you are ready to begin discharging. To begin discharging simply press and HOLD the ENTER button for a few seconds (please also note that during discharging you can press and hold the ENTER button to end the discharge process).

From there the charger will check the battery while displaying the following screen:



BATTERY CHECK
PLEASE WAIT...

If the battery is connected properly and the charger confirms that all other parameters are correct, discharging will begin automatically.

Data Monitoring During Discharging

Throughout (and after) the discharge process you can view/monitor various data. On the main discharging screen you will see the elapsed duration of the discharge process, the capacity that's been discharged from the battery, the discharge current rate and the voltage of the battery. You can also use the +/ – buttons to switch between the various screens to see the available data.

For example, when discharging a LiPo/Lilon/LiFe battery and on the discharging screen simply press the + button once and you will see the individual cell voltages (when balancing is turned ON). If you press the + button a second time you'll again see the elapsed time, as well as the internal temperature of the charger and the peak voltage of the battery at the beginning of the discharge process. Pressing the + button a third time will show the elapsed time in addition to the input voltage from the power source.

When discharging a NiCd/NiMH/Pb (lead-acid) battery, the first time you press the + button you will see the elapsed time along with the average voltage of the battery that will be shown when the discharge process has ended. Pressing the + button a second time will also show the internal temperature of the charger and the peak voltage of the battery at the beginning of the discharge process, while pressing the + button a third time will show the elapsed time in addition to the input voltage from the power source.

Discharging Completion

Discharging will end automatically when the battery reaches the per cell voltage cutoff set by you. When this occurs you will see the following screen:



BATTERY DISCHARGE
COMPLETE

From there you can press the ENTER button once to display the data from the discharge process. Additionally, the +/- buttons can be used to scroll through other screens, including the screen that features Battery.IR to check the Internal Resistance (IR) of the battery and/or individual cells (for LiPo/Lilon/LiFe and with the balancer connected). While on the Battery.IR screen, press the ENTER button to display the Internal Resistance values. Or, on most other screens you can press the ENTER button to exit the discharge process completely.

Cooling Fans During/After Discharge

During the discharge process one or both fans may come on at low or high settings to help control the internal temperature of the charger. In some cases, even after the discharge process has ended the fans will continue to run even when the internal temp has reached near ambient temperature. If this happens you can power the charger off then on again and the fans will remain off until the next charge/discharge process begins.

CYCLE MODE

The TP1430C is capable of charging/discharging batteries automatically by cycling them up to 15 times. This can be particularly useful for testing and/or rejuvenating NiCd/NiMH batteries. **Please note that we DO NOT recommend cycling LiPo/Lilon/LiFe batteries as it comes at great risk unless you monitor all charge/discharge cycles in person fully and set the discharge cutoff voltage to a level high enough to prevent over-discharge.** Additionally, it has been shown that, unlike other chemistries such as NiCd/NiMH, it is typically not possible to rejuvenate LiPo/Lilon/LiFe cells/batteries through charge/discharge cycling.

Please also keep in mind that aside from selecting the order of charge->discharge (CHG->DCHG) or discharge->charge (DCHG->CHG) and the number of cycles, you must set the chemistry type, cell count, capacity, and charge current rate in the Charge Mode, and the discharge current rate and the per cell voltage cutoff in the Discharge Mode. After setting the correct values in the Charge Mode, wait until none of the adjustable values are flashing, then press the + button once to enter the Discharge Mode. After setting the correct values in the Discharge mode, wait until none of the values are flashing then press the + button one more time to enter the Cycle Mode.

Cycle Order

You can select the cycle order, charge->discharge (CHG->DCHG) or discharge->charge (DCHG->CHG), by using this setting. To change the order simply press the ENTER button once then use the +/- buttons to adjust the order accordingly.

Cycle Number

This allows you to set the number of cycles the charger will automatically perform from 1 to 15. To set the number simply press the ENTER button twice and use the +/- buttons to adjust the number of cycles accordingly.

Cycling the Battery

After setting the correct battery chemistry type, cell count, capacity and charge current rate in the Charge Mode, and the correct discharge current rate and voltage cutoff in the Discharge Mode along with the cycle order and number of cycles, you are ready to begin cycling. To begin cycling simply press and HOLD the ENTER button for a few seconds (please also note that during cycling you can press and hold the ENTER button to end the cycling process).

From there the charger will check the battery while displaying the following screen:



If the battery is connected properly and the charger confirms that all other parameters are correct, cycling will begin automatically.

Data Monitoring During Cycling

Throughout (and after) the cycling process you can view/monitor various data. On the main cycling screen you will see the elapsed duration of the current charge or discharge process, the capacity that's been charged into/discharged from the battery, the charge/discharge current rate and the voltage of the battery.

Also, it will be possible to identify whether the charger is charging or discharging for the current cycle, as well as the number of the current cycle, by looking at the 'C00D' info located in the middle of the upper line on the screen. When the 'C' is flashing the charger is charging, and when the 'D' is flashing the charger is discharging. And the number of the current cycle, 01 through 15, will be displayed between the C and D accordingly.

You can also use the +/- buttons to switch between the various screens to see the other available data. For example, when cycling a NiCd/NiMH battery, the first time you press the + button you will again see the elapsed time along with the average voltage of the battery that will be shown when the discharge process has ended. Pressing the + button a second time will also show the internal temperature of the charger and the peak voltage of the battery during the charge or at the beginning of the discharge process.

Cycling Completion

Discharging will end automatically when the battery reaches the per cell voltage set by you. When this occurs you will see the following screen:



From there you can press the ENTER button once to display the data from the cycling process, as well as use the +/- buttons to scroll through other screens, and on most other screens you can press the ENTER button to exit the charge process completely. It's also important to note that the data from the completed cycling process can also be viewed in the Data View mode after exiting the process and before the next charge/discharge process begins.

STORAGE MODE

The TP1430C features an advanced Storage Mode that automatically discharges and/or charges the battery for safe and healthy storage. **For added reference you should NEVER store LiPo batteries at full charge for more than few hours at most and they should be stored at temperatures of 40-75° F whenever possible to prevent swelling and/or loss of performance/capacity. Instead you should use the Storage Mode to automatically charge or discharge them to approximately 50% capacity (~3.85V per cell), especially if the battery is more than 50% charged and will not be used in the next few hours.**

Please also keep in mind that you must set the chemistry type, cell count, capacity and charge current rate in the Charge Mode and the discharge current rate and voltage cutoff in the Discharge Mode. These are the values used by the charger to automatically charge/discharge the battery accordingly in the Storage Mode. In the case of LiPo/Lilon batteries, the charger will automatically charge (if the voltage is below approximately 3.85V per cell) or discharge (if the voltage is above approximately 3.85V per cell) the battery to approximately 3.85V per cell, and for LiFe batteries to approximately 3.3V per cell. For NiCd/NiMH batteries the charger will automatically discharge them to the discharge voltage cutoff set in the Discharge Mode, then charge them to 50% of the capacity set in the Charge Mode.

Storage Charging/Discharging the Battery

After inputting all the correct settings as required in the Charge Mode and the Discharge Mode, you can begin the storage process by simply pressing and HOLDING the ENTER button for a few seconds (please also note that during the storage process you can press and hold the ENTER button to end the process accordingly).

From there the charger will check the battery while displaying the following screen:



If the battery is connected properly and the charger confirms that all other parameters are correct, the storage process will begin automatically.

Data Monitoring During the Storage Process

Throughout (and after) the storage process you can view/monitor various data. On the main storage screen you will see the elapsed duration of the current charge or discharge process, the capacity that's been charged into/discharged from the battery, the charge/discharge current rate and the voltage of the battery.

Also, it will be possible to identify whether the charger is charging or discharging by looking at the 'CHG' or 'DCHG' info located in the middle of the upper line on the screen. When 'CHG' shows the charger is charging, and when 'DCHG' shows the charger is discharging.

You can also use the +/– buttons to switch between the various screens to see the other available data. For example, when in the storage process for a LiPo/Lilon/LiFe battery simply press the + button once and you will see the individual cell voltages (when balancing is turned ON). And if you press the + button a second time you'll see the elapsed time, the internal temperature of the charger, and the peak voltage of the battery during the charge or at the beginning of the discharge process.

And when in the storage process for a NiCd/NiMH battery, the first time you press the + button you will see the elapsed time along with the average voltage of the battery that will be shown when the discharge process has ended. Pressing the + button a second time will also show the internal temperature of the charger and the peak voltage of the battery during the charge or at the beginning of the discharge process.

Storage Completion

Storage will end automatically when the battery reaches the per cell voltage or capacity set by you. When this occurs you will see the following screen:



```
BATTERY STORAGE
COMPLETE
```

From there you can press the ENTER button once to display the data from the storage process, as well as use the +/- buttons to scroll through other screens, and on most screens you can press the ENTER button to exit the storage process completely.

SETTING DATA MODE

The Setting Data mode of the TP1430C allows you to set the various default data settings for a variety of functions. You can reach the Setting Data mode from any of the Charge, Discharge, Cycle or Storage Mode screens by pressing the MODE button once. From there you can use the +/- buttons to scroll through the available screens/menus accordingly. **It is also important to note that the following data settings apply to all memory profiles: Power Distribution, Input Power LVC, Input Current MAX and Temperature Unit. All other data settings apply to the memory profiles individually.**

Charge End Voltage

The '.....CHG End Voltage' sets the end voltage per cell the charger will achieve before completing/ending the charge process. This value can be set for all chemistry types; however, you must have the chemistry you would like to set the value for selected in the Charge Mode in order for that chemistry to show appropriately in the charge end voltage screen/menu. **It's also important to note that the charge end voltage value can be set PER MEMORY PROFILE** so you can fine-tune the end voltage of the battery, just as you can the chemistry type, capacity, and charge current rate. This is helpful because sometimes batteries of the same cell count and capacity, but different internal resistance/performance levels, may charge to slightly different end voltages when using the same charge end voltage value. In those cases it may be helpful to have the same chemistry type, cell count, capacity, and charge current rate values but different charge end voltage values in two different memory profiles. To adjust this value simply press the ENTER button once and the value will flash. Then use the +/- buttons to increase/decrease the value per your preference and/or the guidelines listed below.

For LiPo batteries, and Lilon batteries with a nominal voltage of 3.7V per cell (and full charge voltage of 4.2V per cell), you can set the charge end voltage up to 4.24V per cell. And although the maximum recommended charge end voltage per cell is 4.235V, due to slight variations in the components and calibration of each charger, resistance of charge leads and cells/batteries, ambient conditions and more, it is possible that when the value is set to 4.24V it will not actually exceed 4.235V per cell when checked with a calibrated Digital Volt Meter (DVM). We first recommend charging with the value set to 4.20V per cell then checking the actual voltage per cell with a calibrated

DVM (DO NOT use a non-calibrated DVM for this check as it can read the voltage too high or too low and cause you to adjust the value incorrectly). If the voltage of each cell is between 4.19V and 4.21V, we suggest leaving the setting as is. Or, if the voltage is even higher or lower you can adjust the value +/- 0.01V and test again until you achieve the desired charge end voltage for your particular charger and batteries (and again, this is adjusted independently per memory). **Please note that this adjustment is to allow for advanced fine-tuning/calibration of the charge end voltage, however, if you do not have a calibrated DVM and/or experience with this type of checking and tuning we suggest leaving the value at 4.20V per cell regardless.**

For Lilon batteries with a nominal voltage of 3.6V per cell, or if you'd like to charge your LiPo batteries to approximately 90% charge in order to extend their cycle life and shorten charge times, the recommended full charge voltage is 4.1V per cell. Use the LiPo Charge Mode and charge end voltage setting, adjusted to 4.10V, to charge the appropriate Lilon batteries (or LiPo batteries to approximately 90% charged) accordingly.

LiFe batteries typically have a recommended full charge voltage of 3.60V per cell. However, you can set the charge end voltage up to 3.80V per cell for the same reasons as noted for LiPo batteries above. Also, please note that this adjustment is to allow for advanced fine-tuning/calibration of the charge end voltage, however, if you do not have a calibrated DVM and/or experience with this type of checking and tuning we suggest leaving the value at 3.60V per cell regardless.

For Pb/Lead-acid batteries, we suggest setting the charge end voltage to the value per cell recommended by the battery manufacturer (as these values do vary from manufacturer to manufacturer). However, a value of approximately 2.25-2.30V per cell (~13.5-13.8V for a typical 6S 12V battery) is typically a safe, conservative value for all Pb/lead-acid batteries.

For NiCd/NiMH batteries you will typically use the Delta Peak Sensitivity value, set in the Charge Mode, to ensure proper peak/full charging of the batteries accordingly. However, in case you set the delta peak sensitivity value too high, you can also set the charge end voltage to complete/finish the charge process instead. In this case we suggest setting the charge end voltage value to 1.60-1.80V per cell because if the value is set too low it will not allow for proper peak/full charging of the batteries.

Input Power LVC/Input Current Max

More detailed information on these settings can be found in the **INPUT POWER SOURCE AND CONNECTION** section found near the beginning of this manual. Please refer to that section for more information.

Cycle Pause Time

The Cycle Pause Time setting is the amount of time that the charger pauses between charge->discharge or discharge->charge cycles when in the cycling process of the Cycle Mode. Generally speaking you should set the pause time to an amount of time that allows the battery to adequately cool between charging/discharging cycles in order to prevent damage due to over-heating. To set the Cycle Pause Time, simply press the ENTER button once and use the +/- buttons to increase/decrease the amount of time as needed.

Charge Capacity Limit

The CHG (Charge) Capacity Limit percentage, in conjunction with the Battery Capacity function found in the Charge Mode (see the **Battery Capacity** sub-section of the **CHARGE MODE** section for more

information), adds an additional level of safety to help ensure that even if the charger does not end the charging process correctly per the battery chemistry/type, it will still end the charging process when the set capacity has been reached. Some users purposely use a lower Capacity Limit Percentage in order to stop the charge mode below full capacity as a means to increase cycle life. To adjust the CHG Capacity Limit percentage, simply press the ENTER button twice, then use the +/- buttons to increase/decrease the percentage accordingly.

Safety Timer

The Safety Timer offers another level of safety to help prevent dangerous over-charge that can result in damage to the battery or fire causing damage and/or personal injury. The safety timer will limit the amount of time that a function can go on, and in the case of charging, it will end the charge process when the time limit is reached even if the other functions (such as CHG End Voltage, Capacity Limit, etc.) do not. To adjust the Safety Timer time limit from the minimum to the maximum time allowed, simply press the ENTER button once, then use the +/- buttons to increase/decrease the time accordingly.

If most of your charging will be done at a 1C rate (typically requiring 45-75 minutes for an approximately 70-90% discharged battery to be fully charged), we recommend setting the time to approximately 90-100 minutes. However, please keep in mind that if the time limit is set too low that it is possible the charger will end charging when it reaches the time limit rather than ending the charge appropriately per the chemistry/type (i.e. – delta peak for NiCd/NiMH, CC/CV to CHG End Voltage for LiPo/Lilon/LiFe, etc.), especially if the battery was discharged further than expected and/or is charged at too low of a current rate.

Temperature Cutoff

The Temperature CUTOFF is the internal temperature at which the charger will reduce the amount of charging/discharging power or stop charging/discharging entirely, while remaining powered on, to prevent permanent damage to the charger. However, in the event that the temperature exceeds the cutoff, the charger will power down entirely. To adjust the Temperature CUTOFF simply press the ENTER button twice, then use the +/- buttons to increase/decrease the temperature accordingly.

Key Beep

The Key Beep setting allows you to turn the audible 'beep' associated with key presses ON or OFF. To turn the beep ON or OFF simply press the ENTER button once then use the +/- buttons to turn it on or off accordingly.

End Beep Duration

The End Beep Duration setting allows you to set the duration of the audible 'beeps' associated with the end of the charge, discharge, or other processes. To turn the beep OFF entirely, on for 5, 15, or 30 seconds, or ON indefinitely until you manually turn it off, simply press the ENTER button twice then use the +/- buttons to change the setting accordingly.

Temperature Unit

The Temperature Unit setting allows you to view the temperature readings found throughout various screens in the charger in degrees Celsius or degrees Fahrenheit. To change the temperature unit displayed simply press the ENTER button once then use the +/- buttons to switch between the units accordingly.

DATA VIEW MODE

The Data View mode of the TP1430C allows you to view various data collected within the mode and throughout recently completed charging/discharging processes. You can reach the Data View mode from the Setting Data Mode screen by pressing the MODE button once. From there you can use the +/- buttons to scroll through the available screens/menus accordingly.

Battery Internal Resistance

The TP1430C offers a quick and relatively effective means to measure the approximate Internal Resistance (IR) of LiPo/Lilon/LiFe, NiCd/NiMH and Pb/lead-acid batteries as well as the individual cells of LiPo/Lilon/LiFe batteries when the balance connector is connected to the balancer. However, it's important to note that while IR measurement from the TP1430C and other equipment readily available in the industry can provide valuable insight into the performance of a given battery, the data is not absolute. Even when using lab-quality, calibrated equipment to measure the IR of cells/batteries there are many variables that will affect the IR of a battery at any given time including:

State of Charge (SOC): The IR will read higher when the battery is discharged versus partially charged versus fully charged. As a result you should always measure the IR of batteries at the same SOC in order for the results to be relative and valuable to reference. We suggest checking at full charge as this is the easiest SOC to achieve consistently with nearly all batteries.

Cell/Battery Temperature: The IR will read higher when the cells/battery are cooler versus warmer. This in mind you should always measure the IR of batteries when they are at the same temperature if you would like to compare the relative results directly.

Physical Condition/Age: The IR will read higher in cells that are physically damaged, swollen and/or considerably aged and deliver less voltage and/or capacity under load accordingly. We recommend checking the IR of batteries when they are new, and tracking their relative IR over time as the battery ages. In the case of cells such as those featuring the Thunder Power RC exclusive Generation 6 chemistry, the IR can actually decrease throughout the first 25-100+ cycles while often stabilizing for hundreds more cycles after.

Resistance of the Wire Leads/Connector: Because the IR is being measured through the battery and charger leads, it is possible for them to affect the measurement especially if the gauge of wire is relatively small and/or there are poor connections. We suggest using the same charger leads/connectors and ensuring solid connections at all times when making IR measurements to compare relative results. This can be especially impactful when checking the IR of individual cells of LiPo/Lilon/LiFe batteries through balance connectors as those connectors/connections can often vary greatly in resistance.

Again, due to the myriad possible variables, IR measurement is not absolute and entirely indicative of actual battery performance. However, if you take the time to ensure you check all batteries at the same SOC, temp, with the same leads/connectors, etc. it is indeed possible to achieve relative results that can be compared effectively.

Here is some additional information, including a few generic reference examples, regarding approximate IR measurements/values:

A 3S 11.1V 2250mAh 45C battery will have approximately ½ the IR of a 6S 22.2V 2250mAh 45C of the same make/model, condition, age, etc. This is because the 6S battery has twice the number of cells, and approximately twice the amount of IR as a result. This is not exact as there will be some

differences in the IR due to additional welds between tabs, etc., however, it is a good general reference that higher cell count batteries (of the same capacity/C rating) will have higher IR than lower cell count batteries.

A 3S 11.1V 2250mAh 45C battery will have approximately double the IR of a 3S 11.1V 4500mAh 45C of the same make/model, condition, age, etc. This is because the 4500mAh battery has twice the capacity and approximately ½ the IR as a result. Again, this is not an exact measurement, but is a good general reference that higher capacity cells (of the same capacity/C rating) will typically have lower IR than lower capacity cells.

A 3S 11.1V 2250mAh 45C battery will have lower IR than a lighter weight 3S 11.1V 2250mAh 25C battery. General speaking, if properly rated, the 25C cells will have higher IR, hence the reason they are only able to handle 25C versus 45C continuous discharge rates.

Some additional notes, hints and tips:

Regardless of the C rating, in most cases if the IR of one 2250mAh cell/battery is lower than that of another 2250mAh cell/battery it will be capable of higher charge and discharge rates. However, in some circumstances, due to the typical IR measurement method of most industry equipment, it is not possible to account for all actual variables. For example, if a 2250mAh cell has slightly higher IR than another 2250mAh cell when checked with the TP1430C, it is possible that under a higher load than the TP1430C places on the cell, and with the associated heating in the actual application, the IR of the cell actually changes to become lower than the other cell when used in the same application. This can come as a result of differences in chemistry, materials, actual internal cell construction and/or battery construction. As a result, while measuring the IR with a unit such as the TP1430C can provide a good baseline reference, you should still take the time to test the batteries side by side in the same application in case the other variables affect the actual performance accordingly.

Unfortunately it is not really possible to create a chart that shows what a good IR value versus a bad IR value may be for a given capacity, C rating, make/model of cell/battery. Because even if a cell/battery has twice the IR of another cell/battery of the same make/model, as long as it continues to perform adequately in your actual application it is still very usable. In many cases if the IR of a given cell/battery increases by 50+% from when it was new, it will typically offer noticeably less performance. On the other hand, especially in lower discharge rate applications (such as slow flyer, trainer and 'cruiser' airplanes), an increase in IR can have little to no noticeable impact in performance for quite some time. Therefore, you should continue using batteries regardless of the IR if they continue to perform well enough in your given application.

Also, the various equipment in the industry that offers IR measurement will measure and deliver values based on their own methods and standards. As a result it is not practical to compare the IR measurements for even the same make and model of battery on different makes and models of equipment. And due to variations in the calibration of actual units, ambient conditions, etc., it is not typically practical to compare the measurements for the same make and model of a battery on the same make and model of equipment or even between the two ports of a dual port charger. Instead it is best to make all measurements and to compare the relative results from a single port or the same unit whenever possible.

To Measure Battery Internal Resistance

While on the Battery.IR screen/menu in the Data View Mode, simply connect the battery to the main power/charge lead. Then, press the ENTER button once and after a relatively quick check the charger will display the approximate IR of the battery. Again, this value is not absolute and will vary per the variables previously noted, however, it is still a valuable reference. Also, if you continue to

press the ENTER button over and over do not be alarmed if the value changes. This in mind you should allow the battery to sit/stabilize for at least a 10-20 seconds before making more than a single check of the IR. And in the event that the charger ever seems to 'stick' during the IR measurement process without giving the IR measurement after ~60 seconds, please disconnect the battery and power the charger down immediately.

To Measure Individual Cell Internal Resistance

You can also check the IR of individual cells in LiPo/Lilon/LiFe batteries when the balance connector is connected to the balance connector adapter board. To check individual cell IR, when on the Battery.IR screen/menu simply press the + button once to view the Cell IR screen/menu. Then, press the ENTER button once and after a relatively quick check the charger will display the approximate IR of each cell in the battery. Again, these values are not absolute and will vary per the variables previously noted, however, they can still be a valuable reference. Also, if you continue to press the ENTER button over and over do not be alarmed if the values change. This in mind you should allow the battery to sit/stabilize for at least 10-20 seconds before making more than a single check of the cell IR. And in the event that the charger ever seems to 'stick' during the IR measurement process without giving the IR measurement after ~60 seconds, please disconnect the battery and power the charger down immediately.

Another important consideration is that because the IR of the individual cells is being checked through the balance connectors versus the main power/charge leads used to check the battery IR, the IR values of the individual cells will not always add up to the IR value of the battery. And in some cases variations in the IR values between cells can be attributed more so to their connection to the balancer connector adapter board than the actual condition of the cells. Therefore, as long as the values do not differ greatly (more than ~10-40%) and the battery is remaining relatively well balanced during charge processes, the cells are still likely relatively close in actual resistance. However, significant variations (for example, a cell that measures 200% higher in IR than other cells in the same battery) that cannot be attributed to the connections can indicate a cell that is indeed higher in resistance than others as a result of poor matching, physical damage, defect, etc. Typically such a cell would have issues balancing during the charge process and/or exhibit physical abnormalities not found on the other cell(s). Be sure to monitor any such cell/battery very closely during charge/discharge and/or to remove it from service completely.

Charge/Discharge Mode Data

If you recently completed a charge/discharge process, and before the next process begins, the total elapsed duration of the process, the capacity that was charged into/discharged from the battery, and the end voltage of the battery will be displayed.

Cycle Charge/Discharge Capacity Data

If you recently completed a charge/discharge cycling process, and before the next process begins, the cycle number for the last completed cycle (1-15) will be shown in addition to the CHG CAP/DCHG CAP (Charge and Discharge Capacity) values.

Peak Voltage and Discharge Average Voltage Data

After completing a charge/discharge/cycling process, and before the next process begins, you can view the peak voltage the battery reached through the duration of the charge process and/or the average voltage of the battery during the discharge process.

Individual Cell Voltage Data (for LiPo/Lilon/LiFe Batteries)

You can view the individual cell voltage data for LiPo/Lilon/LiFe batteries at any time after, between, or before a charge/discharge process by connecting the balance connector to the balance connector board (which must also be connected to the balancer/charger) and scrolling to the appropriate screen. The voltages shown are for the individual cells at that moment, with cells 1-4 on the top line (starting with #1 on the left and ending with #4 on the right) and 5-8 on the bottom line. By pressing the “+” again it will show the remaining 9-14 cells. Also, any cells that show 0.00V are not applicable or are not being measured due to a balance connector connection issue. So if you’ve connected a 4S battery but see voltages for only 3 cells be sure to check the connections accordingly.

In some cases the voltage for cell #1 will not show correctly in relation to the rest of the cells in the battery if only the balance connector is connected to the balancer/charger. If you encounter this issue, keep the balance connector connected then also connect the main power leads to the charger. Then, use the +/- buttons to scroll away from and back to the individual cell voltage data screen to refresh the measurement. Now the voltage for cell #1 should also show correctly.

Please also note that while only the second (hundredths) place after the decimal is shown due to the space available on the screen (in order to show voltages for up to 8 cells on a single screen), the charger is measuring and calculating the voltages/balance by using the third (thousandths) place. This means when you see a cell at 3.80V and another at 3.82V the cells are likely as close as 3.804V and 3.816V but the values on the screen are being rounded up and down accordingly.

Real-Time Input Voltage and Output Voltage Data

You can see the voltage from the input power source as well as the voltage at the output if any battery is connected to the charger leads. This is particularly helpful if you’d like to determine the voltage of the battery that is connected without starting a charge/discharge process.

Please also note that while only the second (hundredths) place after the decimal is shown the charger is measuring the input/output voltage by using the third (thousandths) place. This means that although the input/output voltage reading may appear to move up and down slightly, the input/output voltage is actually stable.

Internal Temperature Data

The Internal TEMP data displays the internal temperature of the charger. This can be particularly helpful to see if the charger’s temperature is approaching the Temperature Cutoff even before starting a charge/discharge process.

ERROR MESSAGES AND TROUBLESHOOTING

In some cases you may encounter the following error messages:

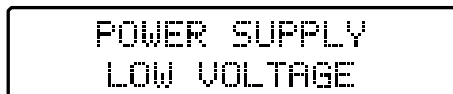

POWER SUPPLY
LOW VOLTAGE

This error message indicates that the voltage from the input power source/supply is too low (below 10.0V).

POWER SUPPLY
HIGH VOLTAGE

This error message indicates that the voltage from the input power source/supply is too high (above 36.0V).

BATTERY VOLTAGE
TOO HIGH

BATTERY VOLTAGE
TOO LOW

These error messages indicate that the battery voltage is too high or too low to be charged/discharged with the chosen settings. For example, if you have the CHG End Voltage set below the current voltage of the battery and attempt to charge.

BATTERY CELL
ERROR

This error message indicates that the selected number of cells does not match the cell count estimated by the charger.

NO BATTERY
CONNECTED

This error message indicates that the battery is not connected and/or there is a problem with the connection to the charger

BALANCE ERROR

This error message indicates that there is a problem with the balance connector connection and/or a significant imbalance.

BATTERY TYPE
ERROR

This error message indicates that the wrong battery type has been selected. For example, you have a LiPo balance connector connected in NiMH mode.

OVER TEMPERATURE
PLEASE WAIT...

FIRMWARE UPDATES

The TP1430C is equipped with a standard mini USB connector that allows the firmware to be updated by the user. Any future updated firmware versions including improved functions, additional features, possible new battery chemistry support and more can be downloaded for free from the Support/Downloads section of the web site at www.ThunderPowerRC.com.

Additional information/instructions regarding how to download the software to install/update the firmware can also be found on the web site. From there you should need only a standard USB (or

mini USB) to mini USB cable to connect the charger to the computer. You can also contact Thunder Power RC directly for any further support.

WARRANTY, SUPPORT AND SERVICE

Limited Warranty Term Period:

Thunder Power RC (TPRC) warrants that the Product(s) purchased (the "Product") will be free from defects in materials and workmanship for the limited warranty term period from the date of purchase by the Purchaser. Please contact TPRC to confirm the limited warranty term period per your Product(s).

Limited Warranty:

- (a) **This warranty is limited to the original Purchaser ("Purchaser") and is not transferable.** REPAIR OR REPLACEMENT AS PROVIDED UNDER THIS WARRANTY IS THE EXCLUSIVE REMEDY OF THE PURCHASER. This warranty covers only those Products purchased from an authorized TPRC dealer. Third party transactions and/or used Products are not covered by this warranty. Proof of purchase is required for warranty claims. TPRC reserves the right to change or modify this warranty without notice and disclaims all other warranties, express or implied.
- (b) **Limitations:** TPRC MAKES NO WARRANTY OR REPRESENTATION, EXPRESS OR IMPLIED, ABOUT NON-INFRINGEMENT, MERCHANTABILITY OR FITNESS FOR A PARTICULAR PURPOSE OF THE PRODUCT. THE PURCHASER ACKNOWLEDGES THAT THEY ALONE HAVE DETERMINED THAT THE PRODUCT WILL SUITABLY MEET THE REQUIREMENTS OF THE PURCHASER'S INTENDED USE.
- (c) **Purchaser Remedy:** TPRC's sole obligation hereunder shall be that TPRC will, at its option, (i) repair or (ii) replace, any Product determined by TPRC to be defective. In the event of a defect, these are the Purchaser's exclusive remedies. TPRC reserves the right to inspect any and all equipment involved in a warranty claim. Repair or replacement decisions are at the sole discretion of TPRC. This warranty does not cover cosmetic damage or damage due to acts of God, accident, misuse, abuse, negligence, commercial use, or modification of or to any part of the Product. This warranty does not cover damage due to improper installation, operation, maintenance, or attempted repair by anyone other than TPRC. Return of any goods by Purchaser must be approved by TPRC via Return Merchandise Authorization (RMA) before shipment.

Damage Limits:

TPRC SHALL NOT BE LIABLE FOR SPECIAL, INDIRECT OR CONSEQUENTIAL DAMAGES, LOSS OF PROFITS OR PRODUCTION, OR COMMERCIAL LOSS IN ANY WAY CONNECTED WITH THE PRODUCT, WHETHER SUCH CLAIM IS BASED IN CONTRACT, WARRANTY, NEGLIGENCE, OR STRICT LIABILITY. Furthermore, in no event shall the liability of TPRC exceed the individual price of the Product on which liability is asserted. As TPRC has no control over use, setup, final assembly, modification or misuse, no liability shall be assumed nor accepted for any resulting damage or injury. By the act of use, setup or assembly, the user accepts all resulting liability.

If you as the Purchaser or user are not prepared to accept the liability associated with the use of this Product, you are advised to return this Product immediately in new and unused condition to the place of purchase.

Questions, Assistance, and Support:

Your local hobby store and/or place of purchase is an excellent source of general support, troubleshooting, etc. However, once assembly, setup, or use of the Product has been started, they

cannot always provide full support, warranty support, or repair. In those cases please contact TPRC directly as this will enable TPRC to better answer your questions and provide the best and fastest possible support and service. For further questions, assistance, and support please visit our web site at www.ThunderPowerRC.com or call 702-228-8883 (M-F, 8:30AM-4:30PM PST) to speak to a Product Support representative.

Inspection or Repairs:

If you purchased this Product outside of the United States (US) and/or are located outside of the US, please contact the authorized TPRC distributor closest to your area before proceeding to the following instructions. You can find contact information for authorized TPRC distributors on our web site, and in most cases those distributors can provide support, inspection, warranty support, and repair. In the event they cannot provide support for any reason please follow the instructions below to work with TPRC, located in the US, directly.

If this Product needs to be inspected or repaired, please contact TPRC for a Return Merchandise Authorization (RMA) either by phone or by visiting the 'Support/FAQs' then 'RMA/Return Merchandise Authorization Forms' section of our web site to fill out the online RMA request form. When submitting the form through the web site you will typically receive a response with more information in 24-48 hours (except on weekends and holidays).

If you do not have internet access, please complete a letter including your full name, street address and a phone number where you can be reached during business hours/days along with a list of the included item(s) and a detailed summary regarding the Product and/or issue.

For return of electronics including chargers, balancers, motors, etc. (not including batteries):

Do not cut or remove any factory-installed wire leads, connectors, etc.

All electronics MUST be packed well within foam, bubble wrap or any other suitable protective material to prevent them from moving around inside the box and/or being damaged during shipping. Warranty will be void for any electronics that are not safely packaged and/or are damaged in shipping. TPRC is NOT responsible to provide warranty coverage for electronics that are damaged during shipping/handling due to inadequate packing and/or shipping carrier abuse. We recommend purchasing shipment insurance equal to a value of at least 50% of the street price for a suitable replacement if you are not confident in the packing and/or shipping carrier.

All electronics MUST be packed and shipped in a "hard" cardboard box ONLY. Because electronics can be damaged during shipping, especially when packed in a "soft" package, there is no way of determining whether damage was caused before or during shipping. As a result the warranty will immediately be void for any electronics shipped in soft or otherwise inadequate packaging.

Please also be sure to include a printed copy of the completed RMA request form (if applicable), along with attached copies of the purchase receipt and any other pertinent documentation, inside of the shipping box. **IMPORTANT NOTE – IF YOU DO NOT INCLUDE A SELLER DATED COPY OF THE PURCHASE RECEIPT, TPRC WILL NOT PROVIDE WARRANTY SUPPORT/SERVICE FOR THE PRODUCT(S) YOU RETURN.**

Label your package accordingly and ship to:

Advance Energy, Inc.
ATTN: Thunder Power RC Product Support
RMA #
4720 W. University Ave.
Las Vegas, NV 89103

Please make sure you obtain a tracking number and/or proof of delivery service for your shipment. TPRC is NOT responsible for any shipments that are lost and/or not proven to be delivered to us.

Once your shipment is received it will be processed and typically subject to the inspection and review process within 5-7 business days. As soon as possible after the inspection and review process is completed, we will contact you with a resolution or to request additional information if required.

Warranty Inspection and Repair or Replacement:

To receive warranty support you **must** include a seller-dated copy of the purchase receipt verifying the proof-of-purchase date. Provided all warranty conditions have been met, your Product will be repaired or replaced under warranty free of charge. Repair or replacement decisions are at the sole discretion of TPRC.

Non-Warranty Repair or Replacement:

Should your Product not be repairable or replaceable under warranty, it may be eligible for repair or replacement at a discount off the current purchase price plus shipping. Also, any product eligible for non-warranty repair or replacement that has been at TPRC for more than 90 days without authorization for work or confirmation of order will be considered abandoned and may be disposed of accordingly.

Instructions for Disposal of WEEE by Users in the European Union:

This product must not be disposed of with other waste. Instead it is the user's responsibility to dispose of their waste equipment by handing it over to a designated collection point for the recycling of electrical and electronic equipment waste. The separate collection and recycling of your waste equipment at the time of disposal will help to conserve natural resources and ensure that it is recycled in a manner that protects human health and the environment. For more information about where you can drop off your waste equipment for recycling, please contact your local city office, your household waste disposal service, or where you purchased the product.



NOTES

©2012 Thunder Power RC
4720 W. University Ave.
Las Vegas, NV 89103 USA
(702) 228-8883
www.ThunderPowerRC.com