

TRACK CONDITIONS Indoor Tight Smooth Hard Packed Blue Groove

Wet Low Bite High Bite Outdoor Open Rough Loose/Loamy

Dry Dusty Wed Bite Other _____

ENGINE Gasket mm Plug Muffler Fuel

Clutch bell 13T 14T 15T Other _____ T Shoes 3 4 Spring mm

DIFF Front Oil # Center Oil # Rear Oil #

_____ T x _____ T Spur gear T _____ T x _____ T

Front Suspension

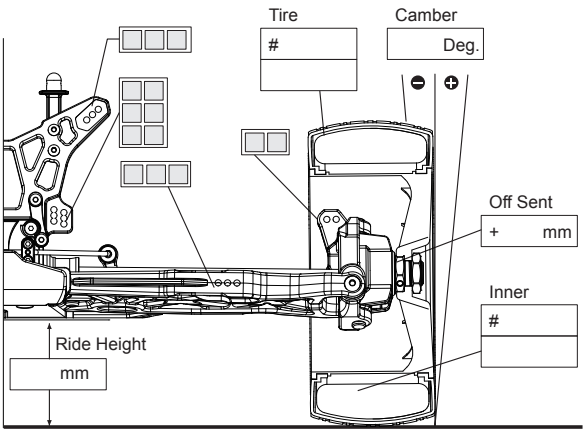

Front Toe angle Caster Angle

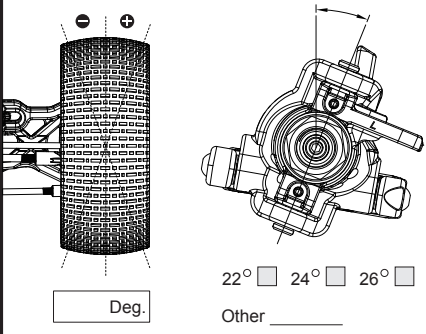

Anti-roll bar FRONT

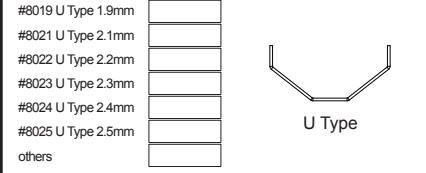

Kick Up



Anti Squat

Toe Angle



Wheel base

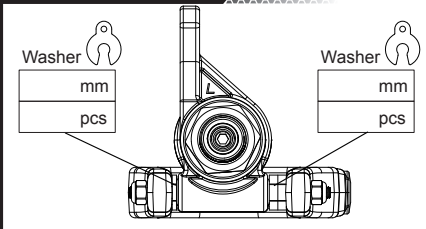

Wing position

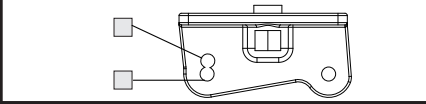

Anti-roll bar REAR

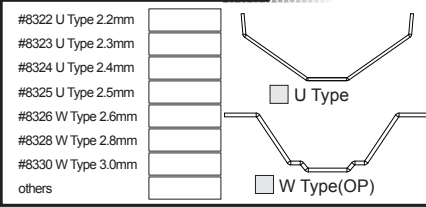

Rear Suspension

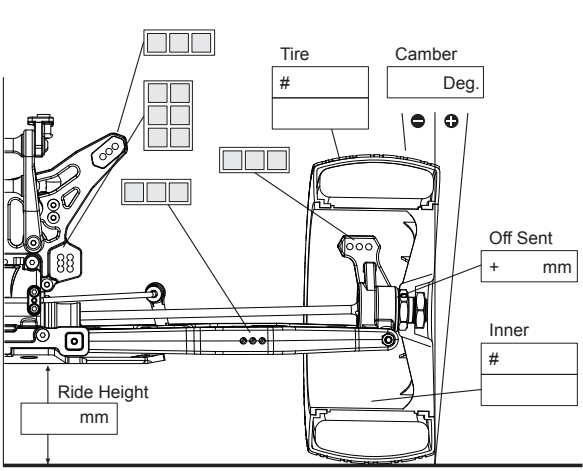

Acker man

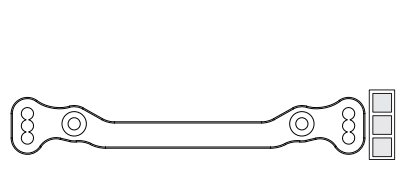

RIDE HEIGHT

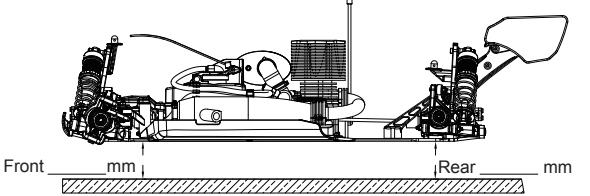

Front Shock

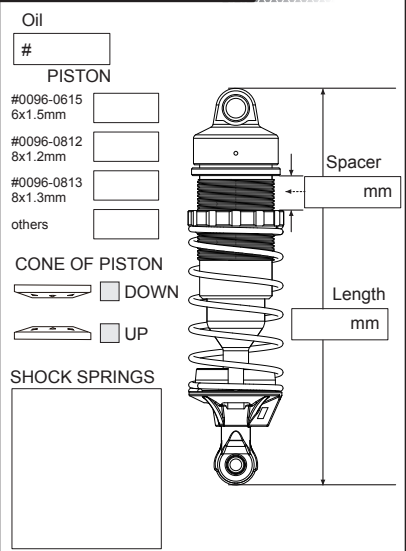

Rear Shock

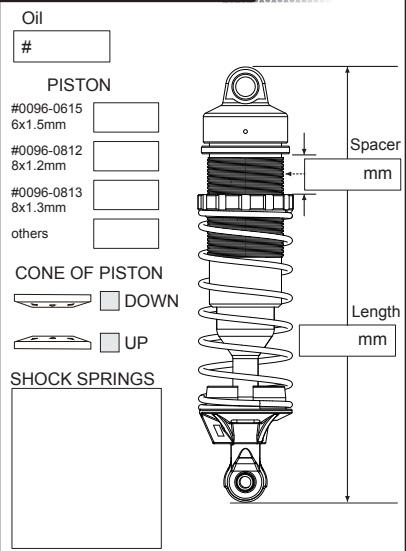

Rebound

