

7000 series Ermeto

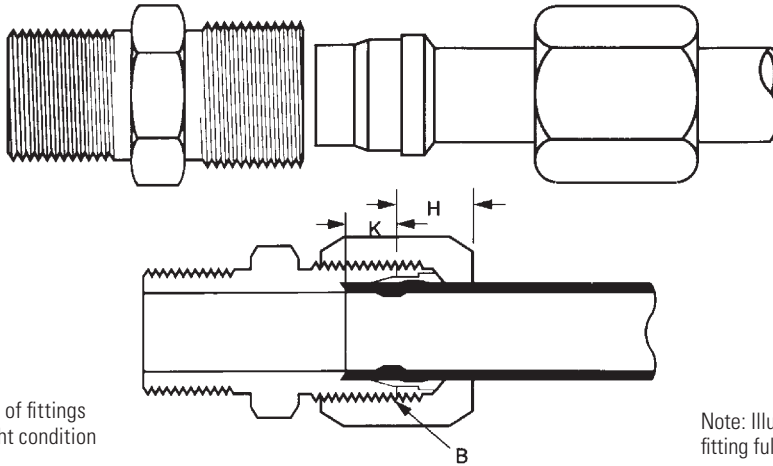

Note: "H" is dimension of fittings assembled to hand tight condition

Note: Illustration shows fitting fully assembled.

Tube O.D.	1/8	3/16	1/4	5/16	3/8	1/2	5/8	3/4	7/8	1	1 1/4	1 1/2	2
Thread size-B	5/16-24	3/8-24	7/16-20	1/2-20	9/16-18	3/4-16	7/8-14	1 1/16-12	1 3/16-12	1 5/16-12	1 5/8-12	1 7/8-12	2 1/2-12
Seat depth-K	0.19	0.24	0.24	0.26	0.26	0.31	0.36	0.36	0.36	0.42	0.42	0.49	0.49
H (Ref.)	0.31	0.30	0.39	0.41	0.47	0.48	0.53	0.55	0.53	0.63	0.56	0.61	0.64

Typical application

Hydraulic, instrumentation and chemical processing systems. Highly recommended for high pressure applications

Pressure

Operating pressure up to 10,000 psi depending on tube and fitting size. See steel fittings recommendations, page J-111

Vibration

Excellent resistance

Temperature range

-65°F to +400°F (-53°C to +204°C) at maximum operating pressures. Has been used at 800°F and 1000 psi to 4000 psi depending on tube size.

Material

Carbon Steel Plating - Zinc Trivalent

Advantages

An excellent high pressure fitting - NO TUBE FLARING. Used with extra heavy wall tubing. Broad selection of sizes and styles

Conformance

Meets specifications and standards of ASME and SAE

How to order

For complete assembly (body, nut sleeve) order individually by part number. Example: 7205x4. To order body only (less nut and sleeve), prefix the part number with the letter Example: B7205X4. Nuts and sleeves can be ordered separately by part number

Adapters and tube fittings

7000 series Ermeto fittings

J

7000 series Ermeto fittings

Ermeto fittings (7000 Series) are especially designed for making leak-proof tube connections. This fitting will effectively withstand high pressure, severe vibration and extreme temperature. No special tools are needed for assembly. Simply cut tube square, preset sleeve on tubing and assemble.

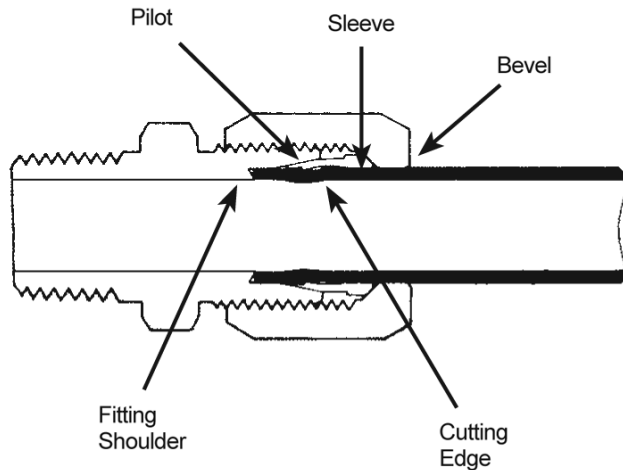

7000 series fittings

Specifically designed to meet all SAE approved standards for hydraulic flareless tube fittings. Available in a complete range of standard body styles.

Carbon steel 7000 series

Eaton Ermeto fittings have a zinc trivalent finish, which fully resists the effects of nonflammable hydraulic fluids.

Ermeto design principle provides positive seal

1. In presetting, as the nut is tightened it forces the sleeve forward into the body taper. See page J-109 for preset instructions.
2. Pilot of sleeve contracts, forcing the cutting edge of sleeve to shear a groove into outer surface of the tube, making a tight joint between fitting and tube.
3. In assembling the preset sleeve and tube into the fitting body, the nut presses on the bevel at rear of sleeve causing it to clamp tightly to the tube. Resistance to vibration is concentrated at this point rather than at the sleeve cut.
4. When fully tightened, the case hardened sleeve is bowed slightly at the midsection and acts as a spring. This spring action of the sleeve maintains a constant tension between the body and the nut, and thus prevents the nut from loosening.
5. After the first assembly, the sleeve is permanently attached to the tube. Disassembly and reassembly of the fitting can be made without loss of strength or sealing qualities.

In general, the "bite-action" of the sleeves in any given material varies as shown in the following table:

"7000" Series Sleeve	Sleeve Material	Tubing used 303 to 316 Stainless and Cupro-Nickel	"Bite-action"
7165	Heat treated carbon steel (standard carbon)	Fully annealed to 1/8 hard	Excellent

7000 series Ermeto fittings Assembly instructions

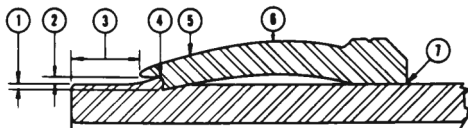
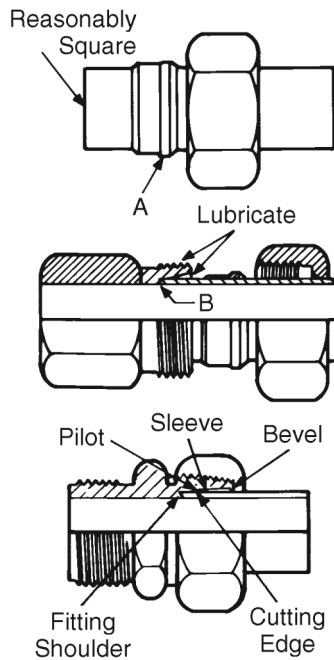

Presetting operation

Preset with preset tool:

1. Slide nut and then sleeve on tube. Shoulder of sleeve "A" must be toward nut.
2. Insert tube into presetting tool. Be sure that tube is bottomed on fitting tube stop at point "B". Lubricate threads, seat of fitting and shoulder of sleeve with good grade of lubricant.
3. Turn nut slowly with wrench while turning tube with other hand. When the sleeve grips the tube, that is, when the tube can no longer be turned by hand - STOP - and note the position of the wrench. This is the "Ring Grip" point.
4. Tighten nut an additional number of turns past the ring grip point per tube size and wall thickness as shown in Table 1, page J-110.
5. Disassemble from preset tool.

Preset in fitting body:

Follow same procedure as when presetting with preset tool. Once the fitting nut has been turned the proper number of turns past ring grip, the fitting assembly is complete and ready for use.

Fitting installation

1. After sleeve and nut have been preset on the tubing and checked as described, the assembly is ready for installation into the Ermeto fitting seat.
2. Lubricate threads, seat of fitting and shoulder of sleeve with a good grade of lubricant compatible with system fluid.
3. Insert tube assembly into fitting and tighten nut until sharp rise in torque is felt.
4. Starting at the position of sharp torque rise, tighten nut 1/4 turn to complete assembly.

When the assembly procedure for Ermeto fittings is followed correctly, these points will be evident:

1. Cutting edge of sleeve will be imbedded in tubing to its full depth.
2. Pilot edge of sleeve should be close to or touching O.D. of tubing.
3. Distance between end of tube and leading or pilot edge of sleeve will be at least 1/8".
4. Metal will be piled ahead of cutting edge of sleeve under pilot.
5. Contact area of sleeve will show evidence of being in perfect contact with tapered seat of fitting.
6. Sleeve will show evidence of being bowed within its elastic limits.
7. Back of sleeve will be in contact with tube.

Note: Performance of fitting will not be affected if sleeve rotates on tube after disassembly.

For re-installation of fitting after disassembly

1. Insert tube assembly into fitting, tighten nut until a sharp rise in torque is felt.
2. Starting at the position of sharp torque rise, tighten nut 1/4 turn to complete the reinstallation.

Adapters and tube fittings

Presetting Ermeto fittings

J

Presetting Ermeto fittings

Table 1: Number of additional turns from “Ring grip” for hand presetting operation—Ermeto sleeve

Tube Size	Tube Material**	Tube wall thickness									
		.018	.022	.028	.035	.049	.065	.083	.095	.109	.120
2	C 1010	1-1/6	1-1/6	1-1/6	1-1/6						
	MiL-T-8504	1-1/6	1-1/6	1-1/6	1-1/6						
3	C 1010	1-1/6	1-1/6	1-1/6	1						
	MiL-T-8504	1-1/6	1-1/6	1-1/6	1						
4	C 1010			1-1/6	1-1/6	1-1/6	1				
	MiL-T-8504			1-1/6	1	1	5/6				
5	C 1010			1-1/6	1-1/6	1-1/6	1				
	MiL-T-8504			1-1/6	1-1/6	1	1				
6	C 1010				1-1/6	1-1/6	1	1			
	MiL-T-8504				1-1/6	5/6	5/6	1			
8	C 1010				1-1/6	1-1/6	1	1	1		
	MiL-T-8504				1-1/6	1	5/6	5/6	5/6		
10	C 1010					1-1/6	1	5/6	5/6	5/6	5/6
	MiL-T-8504					1-1/6	1	5/6	5/6	5/6	5/6
12	C 1010					1	1	5/6	5/6	5/6	
	MiL-T-8504					1-1/6	1	5/6	5/6	5/6	
16	C 1010					1-1/6	1-1/6	5/6	5/6	5/6	
	MiL-T-8504					1-1/6	1-1/6	1-1/6	5/6	5/6	5/6
20	C 1010						1	1	1	5/6	5/6
	MiL-T-8504						1	1	1	5/6	5/6
24	C 1010								1	1	1
	MiL-T-8504										
32	C 1010								1	1	1
	MiL-T-8504										

** C 1010 – carbon steel tubing

** MiL-T-8504 – Annealed stainless steel

Ermeto hand presetting tools 7000 series



Presetting tools provide a more accurate and positive leak-proof method of coupling flareless fittings. Presetting steel Ermeto sleeves on tubing prior to fitting assembly will permit the maximum high performance obtainable with flareless fittings.

Catalog number	Tube O.D.	Thread size
	inches	
T-7002	1/8	5/16-24
T-7003	3/16	3/8-24
T-7004	1/4	7/16-20
T-7005	5/16	1/2-20
T-7006	3/8	9/16-18
T-7008	1/2	3/4-16
T-7010	5/8	7/8-14
T-7012	3/4	1 1/16-12
T-7016	1	1 5/16-12
T-7020	1 1/4	1 5/8-12
T-7024	1 1/2	1 7/8-12
T-7032	2	2 1/2-12

Metric flareless hand presetting tools

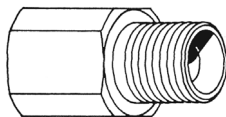

Presetting tools provide a more accurate and positive leak-proof method of coupling flareless fittings. Presetting the steel metric sleeves prior to fitting assembly will permit the maximum high performance obtainable with flareless fittings. These tools are available for the Light (DIN 3901/3902L) flareless series.

Light series 3901/3902L

Catalog number	Tube O.D.	Thread size
	mm	
TL-7008	8	M14x1.5
TL-7010	10	M16x1.5
TL-7012	12	M18x1.5
TL-7015	15	M22x1.5
TL-7018	18	M26x1.5
TL-7022	22	M30x2.0
TL-7028	28	M36x2.0

Ermeto flareless fittings

Hydraulic pressure data

Ermeto fittings have been used with success on many and varied applications far exceeding the conservative conditions presented below. Specifically:

- Temperatures up to 800°F, in carbon steel have been handled without failure
- Burst pressures up to 32,000 psi with 1/4" tubing
- Vibration conditions of 1/8" off-center amplitude with 12" overhang in 1/4" tubing have been withstood at rated operating pressure with 4-to-1 safety factors for over ten million cycles

Obviously under extreme conditions of pressure, temperature and/or vibration, the safety factor is proportionately reduced.

The Ermeto flareless fitting is the ultimate hydraulic fitting available today. Special performance conditions as outlined can be accommodated; however, it is recommended that your local Eaton representative be consulted for engineering assistance prior to finalizing design.

The values shown in the following table are pressure ratings of Ermeto flareless fittings under various surge conditions. They apply and are recommended for conservative operating conditions.

Size no.	Size in inches	Maximum pressure † No surges PSI	Maximum pressure † With surges to 50%	Maximum pressure † With surges of 50% to 100%	Maximum pressure † With surges to 150%
2	1/8	10,000	6,500	5,000	4,000
3	3/16	9,000	6,000	4,500	3,600
4	1/4	8,000	5,250	4,000	3,200
5	5/16	8,000	5,250	4,000	3,200
6	3/8	7,500	5,000	3,750	3,000
8	1/2	7,000	4,500	3,500	2,700
10	5/8	5,000	3,250	2,500	2,000
12	3/4	5,000	3,250	2,500	2,000
14	7/8	3,750	2,500	1,800	1,500
16	1	3,600	2,400	1,800	1,400
20	1 1/4	3,200	2,100	1,600	1,275
24	1 1/2	3,000	2,000	1,500	1,200
32	2	2,750	1,800	1,350	1,100

†Pressures shown do not apply to pneumatic applications.