



***I*Power Series**

——**Pure Sine Wave Inverter**

User's Manual



Model:

IP1500-11

IP1500-21

IP2000-21

IP2000-41

CONTENTS

1. Introduction.....	1
2. Important Safety Instructions.....	2
3. Wiring.....	4
4. Functions.....	6
5. Protection.....	10
6. Troubleshooting.....	12
7. Maintenance and Warranty.....	13
8. Technical Specification.....	14

1. Introduction

Thanks for purchasing IPower series inverters. The product is a pure sine wave inverter which can convert 12/24/48VDC to 110/120VAC 50/60Hz based on full digital and intelligent design. It features high reliability, high efficiency, concise outline, small volume, full protection functions, easy installation and operation. The inverter can be applied in many fields, such as household emergency lighting system, vehicle mounted system and small field power supply, etc.

Features:

- Complete isolation-type inverter technology
- Adoption of advanced SPWM technology, pure sine wave output
- Dynamic current loop control technology to ensure inverter reliable operation
- Wide DC input voltage range
- Low output harmonic distortion ($THD \leq 5\%$)
- Optional output voltage and frequency at 110/120VAC, 50/60Hz
- High conversion efficiency up to 95%
- USB output 5VDC/1A*
- RS485 communication port*
- Extensive Electronic protection

* Only the model of the USB output port or RS485 port.

2. Important Safety Instructions

As an AC power supply equipment, the inverter's output voltage is with the same level as that of household power plug. Mind the AC output terminals, or you may get an electric shock and result in life danger!

Attentions:

- Connect the DC input according to the requirement strictly. The power inverter has a relatively wide input range, but too high or too low input may cause problems even destroy the inverter.
- A reverse polarity connection will blow the fuses in the inverter and may damage the unit.
- Do not expose the inverter to humid, flammable, explosive or dust environment.
- Keep the inverter out of children touch.
- Inverter input is recommended to connect to battery, the min. capacity of battery(expressed in AH) should be calculated in the following way: 5times of the rated power of the inverter/battery voltage. If for testing purpose, user should select DC power supply current at least twice greater than that of the inverter rated input to keep inverter normal operation. Use DC power supply for testing may cause the damage of the inverter.
- When the inverter works continuously, its surface may become very hot, please make sure the air ventilation clearance around the inverter is more than 10cm. Keep away from the material or device which may suffer from high temperature when the inverter is working. Do not install the inverter in airproof location and keep enough space around the inverter.
- The protective grounding must be connected to the ground. The cross section of wire should not be less than 4mm².

- The wire connects between battery and inverter should be shorter than 3m, the current density should be less than $3.5\text{A}/\text{mm}^2$ while the output of inverter is fully loaded. If the wire longer than 3m, the current density should be reduced.
- A fuse or breaker should be used between battery and inverter, the value of fuse or breaker should be twice of the inverter rated input current.
- Do not connect the battery charger or similar devices to the input terminal of the inverter.
- Do not put the inverter close to the flooded lead-acid battery because the sparkle in the terminals may ignite the hydrogen released by the battery.
- It's an off-grid inverter, do not connect the AC output terminals to the grid or electrical source, otherwise the inverter may be damaged.
- This inverter can only be used singly, parallel connection or in series will damage the inverters.
- Risk of electric shock, don't touch output port when the inverter is working. The output is forbidden to connect other power sources or grid, otherwise the inverter will be damaged. The inverter must be in off, when connecting load.
- Do not attempt to repair the fault inverter by yourself, otherwise it may lead to a serious accident. Please contact the manufacture's engineer.

3. Wiring

(1) 12/24/48V system DC input

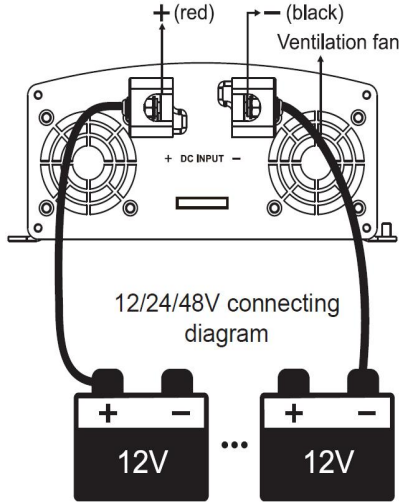

(2) 110/120V AC output

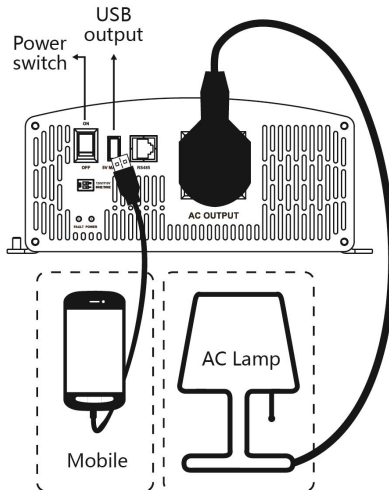

Operation Steps:

Step 1: Turn off the switch of inverter

Step 2: Connect the battery ('+' terminal with red line, '-' with black line). Do not connect them by contraries, or the power inverter will be damaged.

Step 3: Connect the protective grounding to the ground

Step 4: Connect the AC load to the AC outlet

Step 5: Switch on the fuse or breaker. Switch the inverter to ON and then turn on the loads one by one. Check the operation state of both power inverter and loads. 'Green' of the Working indicator means the state is normal.

Step 6: If there are different loads, it is suggested that turn on the load with large startup current first, such as television, then turn on the load such as lamp when the inverter works stably.

Step 7: If the Fault indicator is 'Red' and the buzzer alarms or no output when you turn on devices, switch off the loads and power inverter immediately. Check the system by referring to the troubleshooting guide. Turn on the devices again according to the operation methods after the failure is removed.

4. Functions

■ DC Input Panel

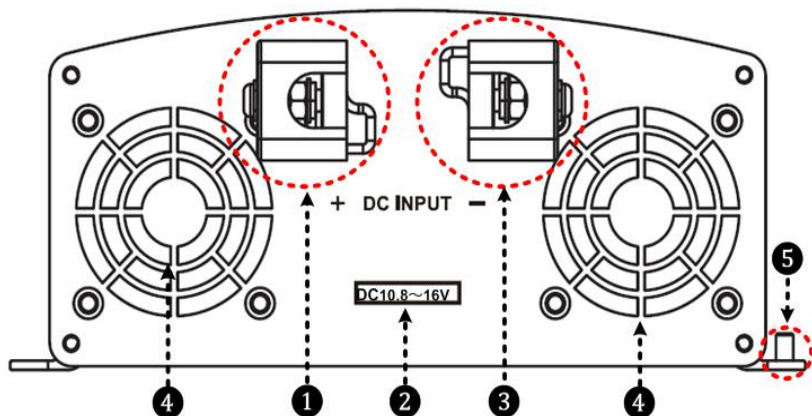

■ AC Output Panel

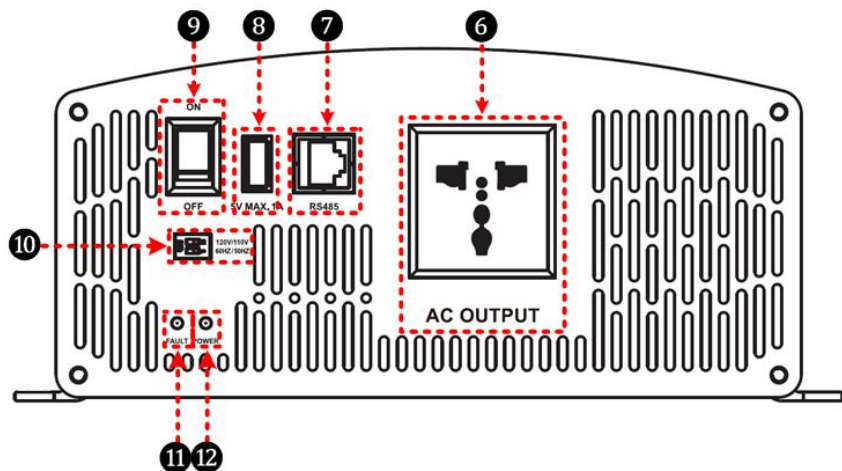

①	DC Input Terminal Positive	⑦	RS485 communication port ⁽⁴⁾
②	DC input voltage range ⁽¹⁾	⑧	USB output port (5VDC/1A)
③	DC Input Terminal Negative	⑨	AC output switch
④	Ventilation Fan ⁽²⁾	⑩	Mode switch ⁽⁵⁾
⑤	Grounding Terminal	⑪	Fault indicator(red) ⁽⁶⁾
⑥	AC Outlet ⁽³⁾	⑫	Working indicator(green) ⁽⁶⁾

(1) Input rated voltage

12V system input voltage range is 10.8~16V;

24V system input voltage range is 21.6~32V;

48V system input voltage range is 43.2~60V。

(2) Fan Ventilation

When the heat sink temperature is higher than 50℃ or internal temperature is higher than 50℃, the fan will turn on automatically.

When the heat sink temperature is lower than 40℃ and internal temperature is lower than 40℃, the fan will turn off automatically.

(3) AC Outlet (optional)

Universal

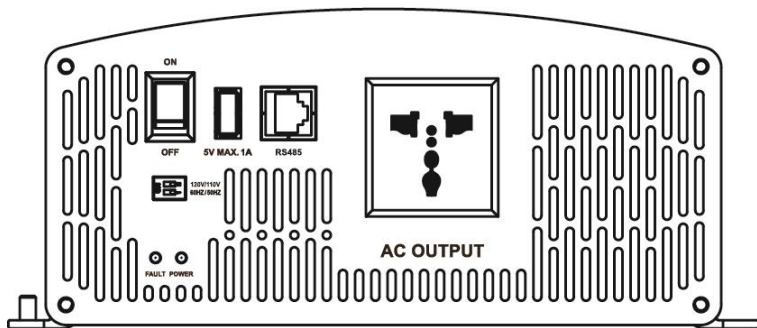

Australia/New Zealand

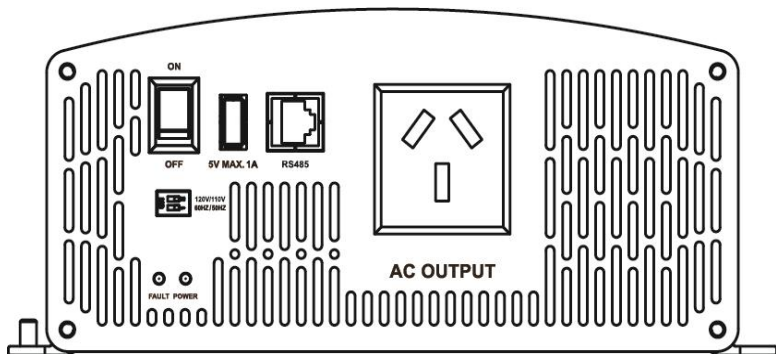

European

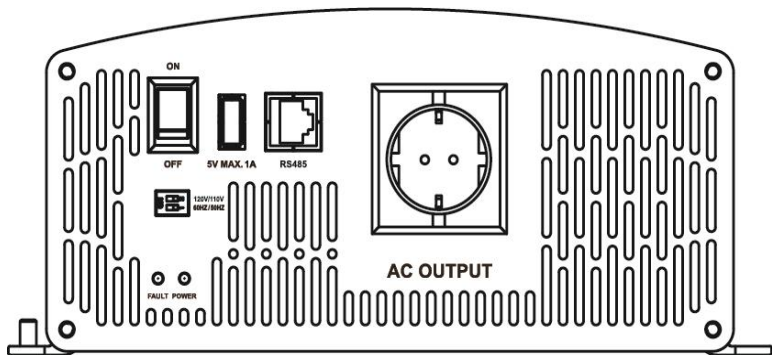

(4) RS485 communication port

The RJ45 interface pin definition is shown below:

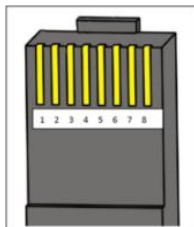

Pins	Define
1/2	—
3/4	RS-485-B
5/6	RS-485-A
7/8	—

(5) Mode Switch

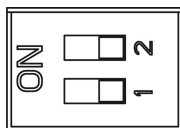

**120V/110V
60HZ/50HZ**

- When the switch No.1 is on the ON side, output frequency is 60Hz, otherwise is 50Hz.
- When the switch No.2 is on the ON side, the output voltage is 120VAC, otherwise is 110VAC.



NOTE: Both the output frequency and the output voltage change availability after restart the inverter.



WARNING: DO NOT turn ON/OFF the mode switch when the inverter is working.

(6) LED indicator and Buzzer

Working indicator	Fault indicator	Buzzer	Status
Green On Solid	Red OFF	No Sounding	Output is ON
Green Slowly Flashing	Red OFF	Sounding	Input under voltage
Green Fast Flashing	Red OFF	Sounding	Input over voltage
Green On Solid	Red On Solid	Sounding	Over temperature
Green OFF	Red Fast Flashing	Sounding	Load short circuit
Green On Solid	Red Slowly Flashing	Sounding	Overload
Green OFF	Red OFF	Sounding	Output voltage abnormal

5. Protection

Protection and recover	Condition				Phenomenon
	Parameter	IPower-12	IPower-22	IPower-42	
Over voltage protection and recover	Input Voltage U_i	$U_i > 16V$	$U_i > 32V$	$U_i > 64V$	Output is OFF Green indicator fast flashing Buzzer sounds
		$U_i \leq 14.5V$	$U_i \leq 29V$	$U_i \leq 58V$	Green indicator on solid The output is on
Low voltage protection and recover	Input Voltage U_i	$U_i < 10.8V$	$U_i < 21.6V$	$U_i < 43.2V$	Output is OFF Green indicator slowly flashing Buzzer sounds
		$U_i \geq 12.5V$	$U_i \geq 25V$	$U_i \geq 50V$	Green indicator on solid The output is on
Over tem. protection and recover	Tem.(T)	Heat sink $T > 80^\circ C$ or Internal $T > 60^\circ C$			Inverter turns OFF
		Heat sink $T \leq 70^\circ C$ and Internal $T \leq 50^\circ C$			Inverter turns ON
Overload	Output power S	$S = 1.2P_e$			Output is OFF after 15min

protection and recover	Rated power P_e		Red indicator slowly flashing Buzzer sounds
		$S=1.5P_e$ ^①	Output is OFF after 1min Red indicator slowly flashing Buzzer sounds
		$S=1.8P_e$ ^①	Output is OFF after 10s Red indicator slowly flashing Buzzer sounds
		$S>2P_e(\text{Rated input voltage})$ ^①	Output is OFF after 5s Red indicator slowly flashing Buzzer sounds
Load short circuit protection ^①			Output is OFF immediately Red indicator fast flashing Buzzer sounds

①When appear output overload protection or load short circuit protection, it has three times auto-recover output function (The first time delay 5s, the second time delay 10s and the third times delay 15s).

6. Troubleshooting

Faults	Possible reasons	Troubleshooting
Green indicator slowly flashing Buzzer sounds	DC input under voltage	Measure the DC input voltage, if the voltage is lower than 10.8/21.6/43.2V. Adjust the input voltage to restore normally.
Green indicator fast flashing Buzzer sounds	DC input over voltage	Measure the DC input voltage, if the voltage is higher than 16/32/64V. Adjust the input voltage to restore normally.
Red indicator slowly flashing Buzzer sounds	Overload	<ul style="list-style-type: none"> • Reduce the number of the AC load. • Restart the inverter.
Red indicator fast flashing Buzzer sounds	Short circuit	<ul style="list-style-type: none"> • Check carefully loads connection, clear the fault. • Restart the inverter.
Green and red indicator on solid Buzzer sounds	Over temperature	When the heat sink temperature exceeds 80°C or the internal temperature exceeds 60°C, the inverter will automatically stop output; When the heat sink temperature below 70°C and the internal temperature below 50°C, the inverter will resume to output.

7. Maintenance and Warranty

The casing of the inverters may be cleaned regularly with a damp cloth (not wet) to prevent accumulation of dust and dirt. The screws on the DC input terminals must be tightened.

The warranty period of the inverter is two years since the date of original shipping. Within the period, we will repair the product or replace the defective product for free. Return the defective with shipping cost prepaid. And provide proof of purchasing date. We will pay the return shipping charges within warranty period.

This warranty does not apply under the following conditions:

- Damage from improper use or use in an unsuitable environment.
- Input voltage exceeds the rated value of inverter.
- The inverter's working temperature exceeds the limit working environment temperature.
- User disassembly or attempted repair the inverter without permission.
- The inverter is damaged due to natural elements such as lightning.
- The inverter is damaged during transportation and shipment.

8. Technical Specification

Technical Parameters

Item \ Model	IP1500-11	IP1500-21
Input Rated Voltage	12VDC	24VDC
Input Voltage Range	10.8~16VDC	21.6~32VDC
Input surge voltage	<20VDC	<40VDC
No-load current	<1.0A	<0.6A
Output Voltage	110VAC(±5%) 120VAC(-7%~+5%)	
Output Continuous Power	1200W	
Output Power 15 min.	1500W	
Instantaneous impact power	2400W	
Output way	Single phase	
Output Wave	Pure sine wave	
Output Frequency	50/60Hz (±0.2%)	
Distortion THD	THD≤5%(Resistive load)	
Max. Efficiency	93%	94%
Max. USB Output	5VDC/1A	
Binding post	Φ10mm	
Overall dimension	326.12×231.5×98.5mm	284.7×231.5×98.5mm
Mounting dimension	208×220mm	163×220mm
Mounting hole size	Φ5.5mm	
Net weight	3.9kg	

Model	IP2000-21	IP2000-41
Item		
Input Rated Voltage	24VDC	48VDC
Input Voltage Range	21.6~32VDC	43.2~60VDC
Input surge voltage	<40VDC	<80VDC
No-load current	<0.6A	<0.4A
Output Voltage	110VAC(±5%) 120VAC(-10%~+5%)	
Output Continuous Power	1600W	
Output Power 15 min.	2000W	
Instantaneous impact power	3200W	
Output way	Single phase	
Output Wave	Pure sine wave	
Output Frequency	50/60Hz(±0.2%)	
Distortion THD	THD≤5%(Resistive load)	
Max. Efficiency	95%	
Max. USB Output	5VDC/1A	
Binding post	φ10mm	
Overall dimension	326.12×231.5×98.5mm	
Mounting dimension	208×219.5mm	
Mounting hole size	φ5.5mm	
Net weight	4.0kg	

Environmental Parameters

Working Temperature	-20°C~+45°C
Storage Temperature	-35°C~ +70°C
Humidity	< 95%(N.C.)
Enclosure	IP20
Altitude	< 5000 m (Derating to operate according to IEC62040 at a height exceeding 1000 m)

Others

Dielectric Strength	Between DC input terminals and metal case: Test voltage AC1500V, 1 minute Between AC output terminals and metal case: Test voltage AC1500V, 1 minute
---------------------	---

Any changes without prior notice! Version number: V1.0



BEIJING EPSOLAR TECHNOLOGY CO., LTD.

Tel: +86-10-82894112 / 82894962

Fax: +86-10-82894882

E-mail: info@epsolarpv.com

Website: <http://www.epsolarpv.com/>

<http://www.epever.com/>