









P-51D Mustang 20cc

Almost-Ready-To-Fly

HANGAR 9



Instruction Manual
Bedienungsanleitung
Manuel d'utilisation
Manuale di Istruzioni

	69.5 in (1.76 m)
	848.0 sq in (54.7 dm ²) Total/Totale
	60.0 in (1.52 m)
	11.5–13 lbs (5200–5900 g)
	2-Stroke Gas: 20cc, 4-Stroke gas/petrol: 20cc 2-Takt Benziner: 20cc, 4-Takt Benzin: 20 cc 2 temps Essence: 20cc, 4 temps essence: 20cc 2-Tempi Gas: cc, 4 tempi benzina: 20 cc
	Electric Power: Power 60, 470Kv Brushless Elektro Antrieb Power: Power 60, 470Kv Brushless Moteur électrique (EP): Power 60, 470Kv Brushless Motore elettrico: Power 60, 470Kv Brushless
	7-channel (or greater) with 7 servos 7-Kanal (oder größer) mit 7-Servos 7 voies (ou plus) avec 7 servos a 7 canali (o più) con 7 servo
	Spinner: 3 ³ / ₄ inch(Included) Spinner: 95mm(Enthalten) Cône: 95mm (Fourni) Ogiva dell'elica: 95mm (Inclusa)
	6.25-inches (159mm)



Part #	English	Deutsch	Français	Italiano
REPLACEMENT PARTS • ERSATZTEILE • PIÈCES DE RECHANGE • PEZZI DI RICAMBIO				
A HAN282001	Fuselage with Hatch	Rumpf mit Haube	Fuselage avec capot	Fusoliera con portello
B HAN282002	Left-Hand Wing with Aileron and Flap	Tragfläche Links mit Querruder und Klappe	Aile gauche avec aileron et volet	Semiala sinistra con alettone e flap
C HAN282003	Right-Hand Wing with Aileron and Flap	Tragfläche Rechts mit Querruder und Klappe	Aile droite avec aileron et volet	Semiala destra con alettone e flap
D HAN282004	Stabilizer with Elevator	Höhenruderset	Set Plan horizontal et Gouverne de profondeur	Set stabilizzatore ed elevatore
E HAN282005	Rudder	Seitenleitwerk	Gouverne de direction	Timone
F HAN282006	Cowling and Exhaust	Motorhaube und Auspuff	Capot et échappement	Cappottatura e scarico
G HAN282007	Top Hatch	Obere Abdeckung	Trappe supérieure	Portello superiore
H HAN282008	Canopy	Kabinenhaube	Verrière	Calotta
I HAN282009	Painted Pilot	Lackierter Pilot	Pilote peint	Pilota verniciato
J HAN282010	Pushrod Set	Gestänge / Anlenkungen Set	Jeu de tringleries	Set dell'asta di spinta
K HAN282011	Hardware Set	Kleinteile Set	Sachet de visserie	Set dei pezzi
L HAN282012	Main Wheels	Fahrwerksräder Set	Paire de roues principales	Set ruota principale
M HAN282013	Decal Set (3)	Dekorbögen (3)	Planche de décoration (3)	Foglio con decalcomanie (3)
N HAN282014	Tailwheel	Spornrad	Roue de queue	Ruotino di coda
O HAN282015	Spinner	Spinner	Cône	Ogiva dell'elica
P HAN282016	Main Landing Gear Struts	Hauptfahrwerk-Streben	Jambes du train d'atterrissage principal	Gambe del carrello di atterraggio principale
Q HAN282017	Wing Tube	Tragflächenverbinder	Clé d'aile	Tubo dell'ala
R HAN282019	Engine Mount Set	Motor-Montagesatz	Jeu de renfort moteur	Set di montaggio motore
S HAN282020	Radio Antenna	Funkantenne	Antenne de la radio	Antenna radio
T HAN282021	Gear Door Set	Fahrwerkklappen-Satz	Jeu de trappes de train	Set portello del carrello
U HAN282022	Scale Detail Parts	Scale Zubehör Paket	Sachet d'accessoires maquette	Pacchetto accessori in scala
SMALL PARTS (NOT SHOWN) • KLEINTEILE (NICHT ABGEBILDET) • PETITES PIÈCES (NON REPRÉSENTÉES) • PARTI DI PICCOLE DIMENSIONI (NON MOSTRATE)				
HAN282018	Fuel Tank	Kraftstofftank	Réservoir de carburant	Serbatoio del carburante
REQUIRED RADIO EQUIPMENT • ERFORDERLICHE RC AUSRÜSTUNG • ÉQUIPEMENT RADIO REQUIS • APPARECCHIATURE RADIO NECESSARIE				
SPMA3000 x3	Heavy-Duty Servo Extension 3-inch	Servokabelverlängerung 75 mm (3 inch)	Rallonge de servo, 75 mm	Estensione servo 3 pollici
EFLG510	60-120 85 degree Strut Ready Main Electric Retract	60-120 85 Grad Strebe einsatzbereit elektrische Haupteinfahrvorrichtung	Système de rentrée électrique principal à 85 degrés 60-120, prêt à être monté sur jambe	Elemento retrattile elettrico principale 60-120, 85 gradi, pronto da montare
SPMA3001 x2	Heavy-Duty Servo Extension 6-inch	Servokabelverlängerung 150 mm (6 inch)	Rallonge de servo, 150 mm	Estensione servo 6 pollici
SPMA3002 x4	Heavy-Duty Servo Extension 9-inch	Servokabelverlängerung 230 mm (9 inch)	Rallonge de servo, 230 mm	Estensione servo 9 pollici
SPMA3003 x2	Heavy-Duty Servo Extension 12-inch	Servokabelverlängerung 300 mm (12 inch)	Rallonge de servo, 300 mm	Estensione servo 12 pollici
SPMAR9350	AR9350 9 Channel AS3X Receiver	AR9350 AS3X-Empfänger mit 9 Kanälen	Récepteur AS3X 9 canaux AR9350	Ricevitore AS3X a 9 canali AR9350

Part #	English	Deutsch	Français	Italiano
❑ 2-STROKE GAS • 2-TAKT BENZINER • 2 TEMPS ESSENCE • 2-TEMPI A BENZINA				
APC16080	Competition Pattern Propeller, 16 x 8	Competition Propeller, 16 x 8	Hélice 16 x 8 Competition	Elica da competizione, 16 x 8
DUB799	Tygon® Gas Tubing, 3' Medium	Tygon-Gasrohre, 1 m (3 Fuß) m Durchschnitt	Tube à essence Tygon, 91,4 cm (3 pi) moyen	Tube per carburante Tygon, 3 piedi, medio
EVOA112	Evolution 3 Wire Ignition/RX Switch	Evolution Zündschalter	Interrupteur Evolution 3 fils Allumage/RX	Evolution, interruttore a 3 fili accensione/ ricevitore
EVOE20GX2	20GX Gas Engine w/Pumped Carb	20GX 20cc (1.20 cu. in.) Benzinmotor	Moteur essence 20GX 20cc	Motore a benzina 20GX 20cc (1.20 cu. in.)
HAN116	Fuel Filler with "T" and Overflow Fitting	Hangar 9 Tanknippel mit T Stück u. Überlauf Fitting	Point de remplissage de carburant avec coupleur en T	Bocchettone di riempimento carburante con
SPM9530	Spektrum™ 3-Wire Switch Harness	Spektrum™ dreiadriges Schalterkabel	Câblage d'interrupteur 3 fils Spektrum™	Interruttore di accensione a 3 fili Spektrum™
SPMB2000LPRX	2000mAh 2S 7.4V LiPo Receiver Battery	LiPo-Empfängerakku (7,4 V / 2000 mAh)	Batterie Li-Po de récepteur 7,4 V 2000 mAh	Batteria per ricevitore da 7,4 V Li-Po, 2.000 mAh
SPMB4000LPRX	4000mAh 2S 7.4V LiPo Receiver Battery	LiPo-Empfängerakku (7,4 V / 4000 mAh)	Batterie Li-Po de récepteur 7,4 V 4000 mAh	Batteria per ricevitore da 7,4 V Li-Po, 4.000 mAh
SPMSA6380 x8	A6380 H-T/H-S Digital HV Servo	A6380 H-T/H-S Digitaler HV-Servo	Servo A6380 H-T/H-S numérique HV	Servo HV digitale H-T / H-S A6380
❑ ELECTRIC POWER • ELEKTROANTRIEB • MOTEUR ELECTRIQUE (EP) • MOTORE ELETTRICO				
EFLM1934	Prop Adapter: Power 46/52/60	Propelleradapter: Power 46/52/60	Adaptateur d'hélice : 46/52/60	Adattatore dell'elica: Power 46/52/60
APC16080E	Electric Propeller, 16 x 8E	Elektro Propeller, 16 x 8E	Hélice électrique, 16 x 8E	Elica elettrica sottile, 16 x 8E
CSE010009700	Talon 90-Amp 25V BL ESC W/20amp BEC	Talon 90 A 25 V bürstenloser Geschwindigkeitsregler mit 20 A BEC	Variateur ESC Talon 90 A 25 V BL avec BEC 20 A	ESC BL Talon 90-Amp 25 V con BEC 20amp
DYNC0021	EC5 Device Connector (2)	EC5 Gerät-Steckverbinder (2)	Connecteur du dispositif EC5 (2)	Connettore dispositivo EC5 (2)
EFLAEC506	EC5 Extension Lead with 6-inch Wire, 10Awg	EC5 Verlängerungsleitung mit 6-Zoll-Kabel, 10Awg	Rallonge EC5 avec fil de 15 cm (6 po), 10 AWG	Cavo di prolunga EC5 con filo da 15,24 cm, 10 AWG
EFLM4060B	Power 60 BL Outrunner Motor, 470Kv	Bürstenloser Außenläufer-Motor Leistung 60, 470Kv	Moteur à cage tournante sans balais Power 60 de 470Kv	Motore brushless a cassa rotante Power 60, 470Kv
KXSB0029	22.2V 7000mAh 6S 30C, 10AWG, EC5	7000 mA 6S 22,2 V 30C LiPo-Akku, 10 AWG EC5	Batterie Li-Po 6S 22,2V 7000mA 30C, 10AWG prise EC5	Batteria LiPo 30C 22,2V 6S 7000 mAh, 10AWG EC5
SPMA3001	Heavy-Duty Servo Extension 6-inch	Servokabelverlängerung 150 mm (6 inch)	Rallonge de servo, 150 mm	Estensione servo 6 pollici
SPMSA6380 x7	A6380 H-T/H-S Digital HV Servo	A6380 H-T/H-S Digitaler HV-Servo	Servo A6380 H-T/H-S numérique HV	Servo HV digitale H-T / H-S A6380
❑ REQUIRED ADHESIVES • ERFORDERLICHE KLEBSTOFFE • TYPES DE COLLES • ADESIVI NECESSARI				
DLMAD44	Roket Rapid CA 5-10 sec: 20g	Roket Rapid CA 5-10 s: 20 g	Colle cyano Roket Rapid 5-10 sec: 20g	Colla cianoacrilica Roket Rapid 5-10 sec: 20 g
DLMAD45	Roket Max CA 10-20 sec: 20g	Roket Max CA 10-20 s: 20 g	Colle cyano Roket Max 10-20 sec: 20g	Colla cianoacrilica Roket Max 10-20 sec: 20 g
PAAPT715	CA Accelerator	Sekundenkleber (CA) Aktivator	Accélérateur de colle CA	Accelerante colla CA
PAAPT37	5-Minute Epoxy	5 Minuten Epoxy	Époxy 5 minutes	Colla epossidica 5 minuti
PAAPT35	15-Minute Epoxy	15 Minuten Epoxy	Époxy 15 minutes	Colla epossidica 15 minuti
PAAPT42	Threadlock	Schraubensicherungslack	Frein-filet	Frenafiletto
DLMAD12	R/C Modeller Canopy Glue: 4 oz	R/C Modeller Kanzelkleber: 113,4 g (4 oz)	Colle à verrière R/C Modeller: 113g	Colla per capottine R/C Modeller: 4 oz

Part #	English	Deutsch	Français	Italiano
<input type="checkbox"/>	REQUIRED TOOLS • BENÖTIGTES WERKZEUG • OUTILS REQUIS • ATTREZZI NECESSARI			
	C-clamp	Schraubzwinge	Serre joint	Morsetto a C
	Drill	Bohrer	Mini-perceuse	Trapano
	Drill bit: 1/16-inch, 5/64-inch, 3/32-inch, 1/8-inch, 9/64-inch, 5/32-inch, 11/64-inch, 3/16-inch, 13/64-inch, 7/32-inch	Bohrer: 1,5mm, 2mm, 2,5mm, 3mm, 3,5mm, 4mm, 4,5mm, 5mm, 5,5mm, 6mm	Forêt : 1,5mm, 2mm, 2,5mm, 3mm, 3,5mm, 4mm, 4,5mm, 5mm, 5,5mm, 6mm	Punte per trapano: 1,5mm, 2mm, 2,5mm, 3mm, 3,5mm, 4mm, 4,5mm, 5mm, 5,5mm, 6mm
	Felt-tipped pen	Faserstift	Feutre fin effaçable	Pennarello
	Epoxy brush	Pinsel	Pinceau Epoxy	Spazzole epoxy
	Flat file	Flachfeile	Lime plate	Lima piatta
	Hemostats	Klemme	Pince Hemostat	Pinzetta
	Hex wrench: 1.5mm, 2mm, 2.5mm, 3mm	Inbusschlüssel: 1,5mm, 2mm, 2,5mm, 3mm	Tournevis hexagonal: 1,5mm, 2mm, 2,5mm, 3mm	Chiave esag.: 1,5mm, 2mm, 2,5mm, 3mm
	Hobby knife with #11 blade	Hobymesser mit # 11 Klinge	Couteau : Lame numéro 11	Taglierino: #11 lama
	Hook and loop tape	Klettband	Bande auto-agrippante	Nastro a strappo
	Hook and loop straps	Klettgurt	Bandes auto-agrippante	Fascette a strappo
	Isopropyl alcohol	Isopropyl Alkohol	Alcool isopropylique	Alcol isopropilico
	Low-tack tape	Kreppband	Adhésif de masquage	Nastro a bassa aderenza
	Needle nose pliers	Spitzzange	Pince fine	Pinze a becco stretto
	Mixing cups and sticks	Mischbecher und Rührstäbchen	Récipients pour mélanger et bâtons	Contenitori e stick per mixer colla
	Nut driver: 7mm	Steckschlüssel. 7mm	Clés à douilles : 7mm	Chiave per dadi: 7mm
	Paper towels	Papiertücher	Papier absorbant	Asciugamani di carta
	Pencil	Stift	Crayon à papier	Matita
	Phillips screwdriver: #1, #2	Phillips Schraubendreher: #1, #2	Tournevis cruciforme: #1, #2	Cacciavite a croce: #1, #2
	Pin vise	Handbohrer	Porte forets	Trapano manuale
	Pliers	Zange	Pince	Pinze
	Ruler	Lineal	Réglet	Righello
	Sandpaper	Schleifpapier	Papier de verre	Carta vetrata
	Scissors	Schere	Ciseaux	Forbici
	Side cutters	Seitenschneider	Pince coupante	Lama laterale
	Square	Geodreieck	Équerre	Squadra
	Tapered reamer	Zulaufende Reibahle	Alésoir conique	Alesatore rastremato
	Tie wraps	Kabelbinder	Colliers	Fascette avvolgenti
	T-pins	T- Nadeln	Épingles	Spilli a T
	Toothpicks	Zahnstocher	Cure dents	Stuzzicadenti
	Tubing bender	Rohrbieger	Cintreuse	Curvatubi
	Vise grips	Klemmen	Pince-étai	Pinze bloccanti

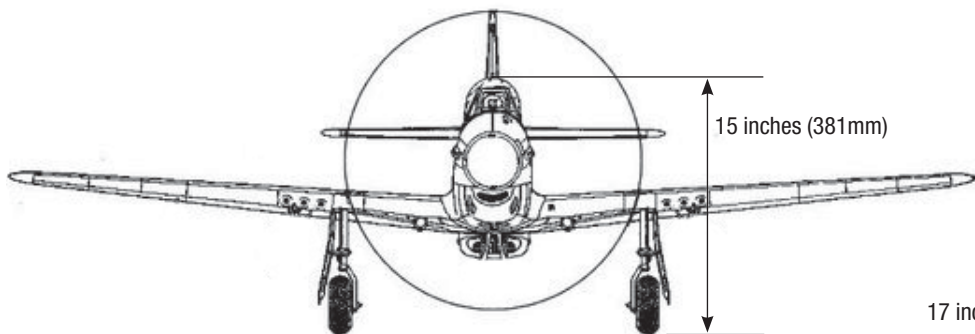

17 inches (431.8mm)

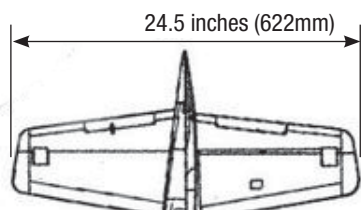
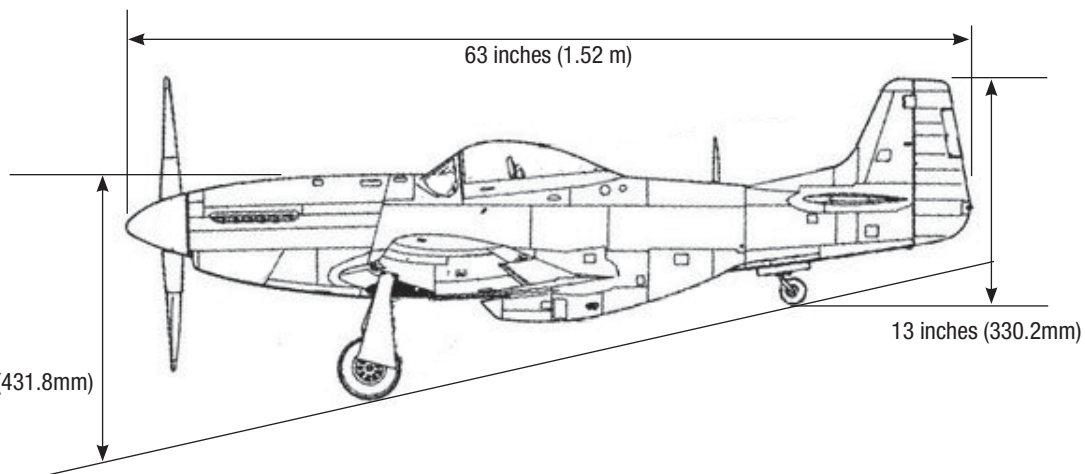



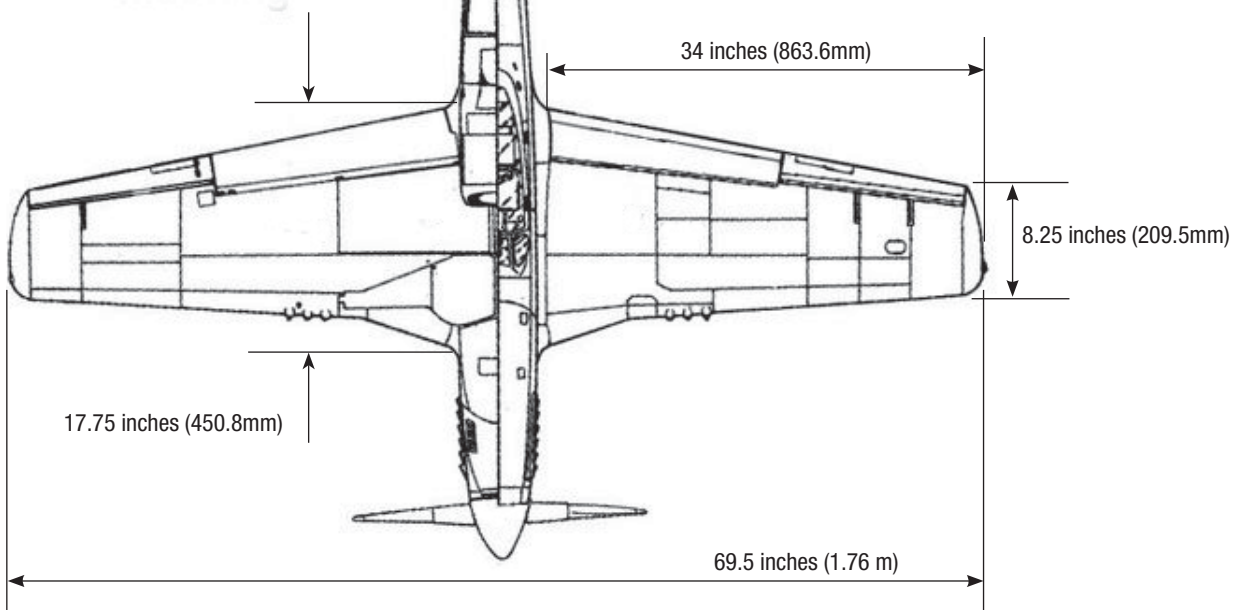





24.5 inches (622mm)



17.75 inches (450.8mm)

69.5 inches (1.76 m)

	69.5 in (1.76 m)
	848.0 sq in (54.7 dm ²) Total/Totale
	60.0 in (1.52 m)
	11.5–13 lbs (5200–5900 g)
	2-Stroke Gas: 20cc, 4-Stroke gas/petrol: 20cc 2-Takt Benzin: 20cc, 4-Takt Benzin: 20 cc 2 temps Essence: 20cc, 4 temps essence: 20cc 2-Tempi Gas: cc, 4 tempi benzina: 20 cc
	Electric Power: Power 60, 470Kv Brushless Elektro Antrieb Power: Power 60, 470Kv Brushless Moteur électrique (EP): Power 60, 470Kv Brushless Motore elettrico: Power 60, 470Kv Brushless
	7-channel (or greater) with 7 servos 7-Kanal (oder größer) mit 7-Servos 7 voies (ou plus) avec 7 servos a 7 canali (o più) con 7 servo
	Spinner: 3 ³ / ₄ inch(Included) Spinner: 95mm(Enthalten) Cône: 95mm (Fourni) Ogiva dell'elica: 95mm (Inclusa)
	6 ¹ / ₄ -inches (159mm)

HANGAR 9[®]

© 2018 Horizon Hobby, LLC.

Hangar 9, Evolution, AS3X, EC5 and the Horizon Hobby logo are trademarks or registered trademarks of Horizon Hobby, LLC.
The Spektrum trademark is used with permission of Bachmann Industries, Inc.
All other trademarks, service marks and logos are the property of their respective owners.

45929

Created 08/2018