

BLADE

230 **S** *Smart*

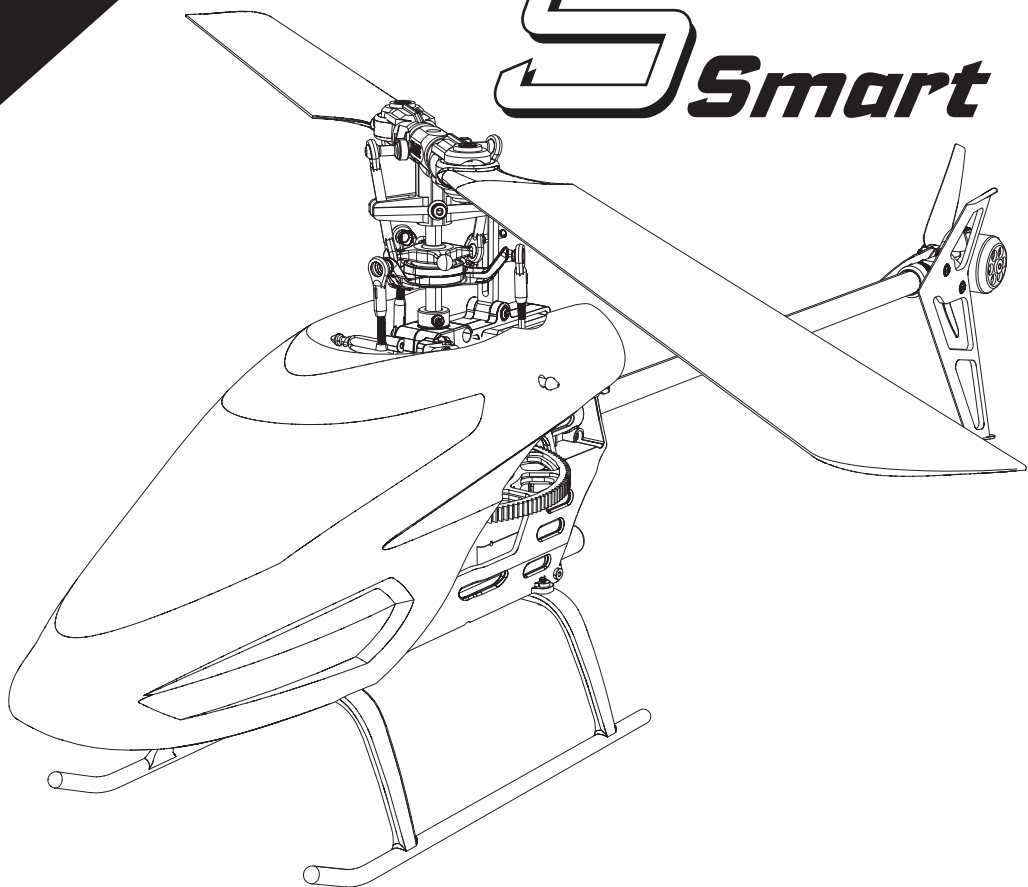

**Instruction Manual
Bedienungsanleitung
Manuel d'utilisation
Manuale di Istruzioni**

SAFE 

BNF
BASIC

RTF
READY-TO-FLY

HORIZON
H O B B Y

Exploded View

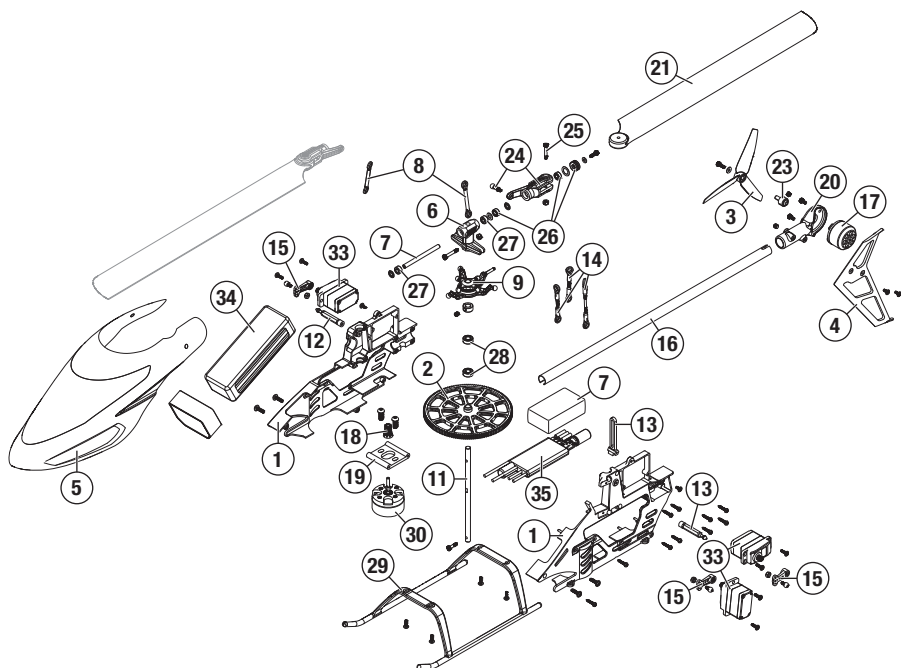

Parts Listings

Part #	Description
	BLH1200 230 S Smart RTF
	BLH1250 230 S Smart BNF
1	BLH1401 Main Frame 230 S V2
2	BLH1402 Main Gear 230 S V2
3	BLH1403 Tailrotor Orange (2) 230 S V2
4	BLH1406 Vertical Fin Orange 230 S V2
5	BLH1407 Canopy 230 S V2
6	BLH1501 Main rotor head Blade 230s
7	BLH1502 Spindle set Blade 230s
8	BLH1504 Rotor head linkage Blade 230s
9	BLH1505 Swashplate Blade 230s
11	BLH1506 Main Shaft Blade 230s
12	BLH1507 Canopy mounting post Blade 230s
13	BLH1508 Anti-rotation bracket Blade 230
14	BLH1509 Servo pushrod set Blade 230s
15	BLH1511 Servo arms set Blade 230s
16	BLH1512 Tail boom Blade 230s
17	BLH1515 Tail motor 3600kv Blade 230s

Part #	Description
18	BLH1516 Pinion gear 12t
19	BLH1518 Motor mount Blade 230s
20	BLH1555 Tail Motor Mount: Night 230 S
21	BLH1577 Option blade (orange) Blade 230
22	BLH1578 Rotor Head Assembly : 230 S
23	BLH2020 Tail Rotor Hub Set: 200SRX
24	BLH4502 Main Rotor Blade Grips: 300 X
25	BLH4503 Main RtrBladeMntng Scw&Nut:300 X
26	BLH4504 Main Grip Bearing Kit: 300 X
27	BLH4505 Dampers (4): 300 X
28	BLH4515 Bearings 4x8x3 (3): 300 X
29	EFLH1502 Landing Gear: BSR
30	EFLH1516 3900Kv Brushless Motor: BSR
31	SPMA3032 Foam Gyro Tape: AR7200BX
32	SPMAR6250MHX Flight Controller: 230 S SMART
33	SPMSH3055M Sub-MicroMetalGearMicroConector
34	SPMX8503S30 850mAh 3S Smart G2 30C; IC2
35	SPMXAE1020 Brushless ESC: 230 S SMART

Optional Parts

Part #	Description
BLH1404	Tail Rotor White (2) 230 S Smart
BLH1514	Vertical Tail Fin (white) 230 S
BLH1573	Canopy 230 S (green) Blade 230 S
BLH1574	Canopy fiberglass (green) Blade 230 S

Part #	Description
BLH1576	Option blade (green)t Blade 230 S
SPMXC1080	Smart S 1100 AC Charger, 1x100W
SPMXCA320	Adapter: IC3 Batt / IC3 Dev 6

Limited Warranty

What this Warranty Covers

Horizon Hobby, LLC, (Horizon) warrants to the original purchaser that the product purchased (the "Product") will be free from defects in materials and workmanship at the date of purchase.

What is Not Covered

This warranty is not transferable and does not cover (i) cosmetic damage, (ii) damage due to acts of God, accident, misuse, abuse, negligence, commercial use, or due to improper use, installation, operation or maintenance, (iii) modification of or to any part of the Product, (iv) attempted service by anyone other than a Horizon Hobby authorized service center, (v) Product not purchased from an authorized Horizon dealer, (vi) Product not compliant with applicable technical regulations, or (vii) use that violates any applicable laws, rules, or regulations.

OTHER THAN THE EXPRESS WARRANTY ABOVE, HORIZON MAKES NO OTHER WARRANTY OR REPRESENTATION, AND HEREBY DISCLAIMS ANY AND ALL IMPLIED WARRANTIES, INCLUDING, WITHOUT LIMITATION, THE IMPLIED WARRANTIES OF NON-INFRINGEMENT, MERCHANTABILITY AND FITNESS FOR A PARTICULAR PURPOSE. THE PURCHASER ACKNOWLEDGES THAT THEY ALONE HAVE DETERMINED THAT THE PRODUCT WILL SUITABLY MEET THE REQUIREMENTS OF THE PURCHASER'S INTENDED USE.

Purchaser's Remedy

Horizon's sole obligation and purchaser's sole and exclusive remedy shall be that Horizon will, at its option, either (i) service, or (ii) replace, any Product determined by Horizon to be defective. Horizon reserves the right to inspect any and all Product(s) involved in a warranty claim. Service or replacement decisions are at the sole discretion of Horizon. Proof of purchase is required for all warranty claims. SERVICE OR REPLACEMENT AS PROVIDED UNDER THIS WARRANTY IS THE PURCHASER'S SOLE AND EXCLUSIVE REMEDY.

Limitation of Liability

HORIZON SHALL NOT BE LIABLE FOR SPECIAL, INDIRECT, INCIDENTAL OR CONSEQUENTIAL DAMAGES, LOSS OF PROFITS OR PRODUCTION OR COMMERCIAL LOSS IN ANY WAY, REGARDLESS OF WHETHER SUCH CLAIM IS BASED IN CONTRACT, WARRANTY, TORT, NEGLIGENCE, STRICT LIABILITY OR ANY OTHER THEORY OF LIABILITY, EVEN IF HORIZON HAS BEEN ADVISED OF THE POSSIBILITY OF SUCH DAMAGES. Further, in no event shall the liability of Horizon exceed the individual price of the Product on which liability is asserted. As Horizon has no control over use, setup, final assembly, modification or misuse, no liability shall be assumed nor accepted for any resulting damage or injury. By the act of use, setup or assembly, the user accepts all resulting liability. If you as the purchaser or user are not prepared to accept the liability associated with the use of the Product, purchaser is advised to return the Product immediately in new and unused condition to the place of purchase.

Law

These terms are governed by Illinois law (without regard to conflict of law principals). This warranty gives you specific legal rights, and you may also have other rights which vary from state to state. Horizon reserves the right to change or modify this warranty at any time without notice.

WARRANTY SERVICES

Questions, Assistance, and Services

Your local hobby store and/or place of purchase cannot provide warranty support or service. Once assembly, setup or use of the Product has been started, you must contact your local distributor or Horizon directly. This will enable Horizon to better answer your questions and service you in the event that you may need any assistance. For questions or assistance, please visit our website at www.horizonhobby.com, submit a Product Support Inquiry, or call the toll free telephone number referenced in the Warranty and Service Contact Information section to speak with a Product Support representative.

Inspection or Services

If this Product needs to be inspected or serviced and is compliant in the country you live and use the Product in, please use the Horizon Online Service Request submission process found on our website or call Horizon to obtain a Return Merchandise Authorization (RMA) number. Pack the Product securely using a shipping carton. Please note that original boxes may be included, but are not designed to withstand the rigors of shipping without additional protection. Ship via a carrier that provides tracking and insurance for lost or damaged parcels, as Horizon is not responsible for merchandise until it arrives and is accepted at our facility. An Online Service Request is available at http://www.horizonhobby.com/content/_service-center_render-service-center. If you do not have internet access, please contact Horizon Product Support to obtain a RMA number along with instructions for submitting your product for service. When calling Horizon, you will be asked to provide your complete name, street address, email address and phone number where you can be reached during business hours. When sending product into Horizon, please include your RMA number, a list of the included items, and a brief summary of the problem. A copy of your original sales receipt must be included for warranty consideration. Be sure your name, address, and RMA number are clearly written on the outside of the shipping carton.

NOTICE: Do not ship Li-Po batteries to Horizon. If you have any issue with a Li-Po battery, please contact the appropriate Horizon Product Support office.

Warranty Requirements

For Warranty consideration, you must include your original sales receipt verifying the proof-of-purchase date. Provided warranty conditions have been met, your Product will be serviced or replaced free of charge. Service or replacement decisions are at the sole discretion of Horizon.

Non-Warranty Service

Should your service not be covered by warranty, ser-



©2020 Horizon Hobby, LLC.

Blade, the Blade logo, E-flite, BNF, the BNF logo, DSM, DSM2, DSMX, SAFE, the SAFE logo, Spektrum AirWare and ModelMatch are trademarks or registered trademarks of Horizon Hobby, LLC.

The Spektrum trademark is used with permission of Bachmann Industries, Inc.

All other trademarks, service marks and logos are property of their respective owners.

US 9,930,567. US 10,419,970. Other patents pending.

Created 10/20

61386

BLH1400, BLH1450