



Dear Customer:

Thank you for purchasing the Integrated RR Crossing Kit using Lamplighter® DFL.

Here is the minimum list of items that you will find inside the box. If you have ordered extra detectors they will be listed on the outside of the box.

- 1 Lamplighter® DFL for Xings or Block Signals
 - Velcro strip for attaching the DFL unit to your layout
- 2 Railroad Xings or Block Signals
- 2 IR Detectors
 - 2 wires
 - 2 Covers for the detectors
 - 4 screws
 - 2 Mounting brackets
- 1 Crossing Bell (if Railroad Xing is included)
- 1 Power Supply

Also included are instruction sheets for

- How to use the Lamplighter DFL unit.
- Mounting the detectors
- Schematic of a typical component layout showing Railroad Xing. The same schematic applies to Block Signal layout.

We hope that you will find this kit the easiest approach to adding Railroad Xings or Block Signals to your layout.

Blessings

Dwarvin Enterprises Ltd.
CS@Dwarvin.com

Lamplighter® DFL Instructions
(Dedicated RR Crossing / Block Signal controller)

This control module allows you to control 2 Railroad Crossing Signals or 2 dual color Block Signals without any need to program. Just insert the fibers from the Signals into the “Fiber Chimneys” and insert the wires from the detectors and bell (for the RR Crossing configuration) and you are done. This is the easiest set up for Signals that you will find on the market.

Crossings Jumper Pins:

To function as a Crossing leave them in their default position covering the 4 pins to the left. Each jumper is mounted perpendicular (at right angles) to the labels on the board.

Set for Block Detection:

Move the jumpers to cover the 4 pins to the right.

Detectors and bell are connected into the screw terminals (Gnd and 5V out TRG (trigger).

RR Crossing Jumper Pins

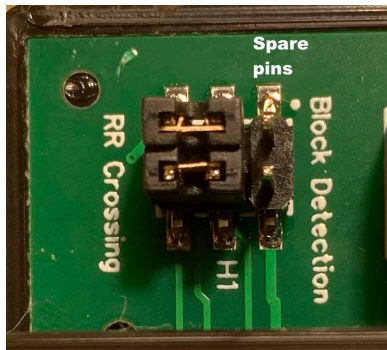

Block Signal Jumper Pins

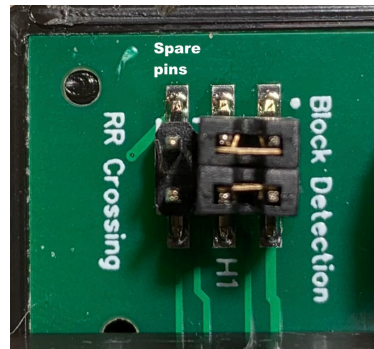

- 2 sets of “Fiber Chimneys”(Yellow dots) with 2 fibers each.
- Insert 2 fibers from each RR Crossing or Block Signal into each Chimney
- 1mm for HO, 0,75mm for N, and 1.5mm for O Signals.
- Insert the power inputs (Red and Black) of the Detectors and Bell into the right two Terminals - Red on the extreme right.
- The Trigger wire goes into the extreme left of the Terminals.
- The unit comes with an automatic 5sec turn off delay after being triggered.

Enjoy the simplicity of this system

Schematic: Implementation of Lamplighter® DFL for 2 Xing Signals, 2 Detectors and Xing Bell

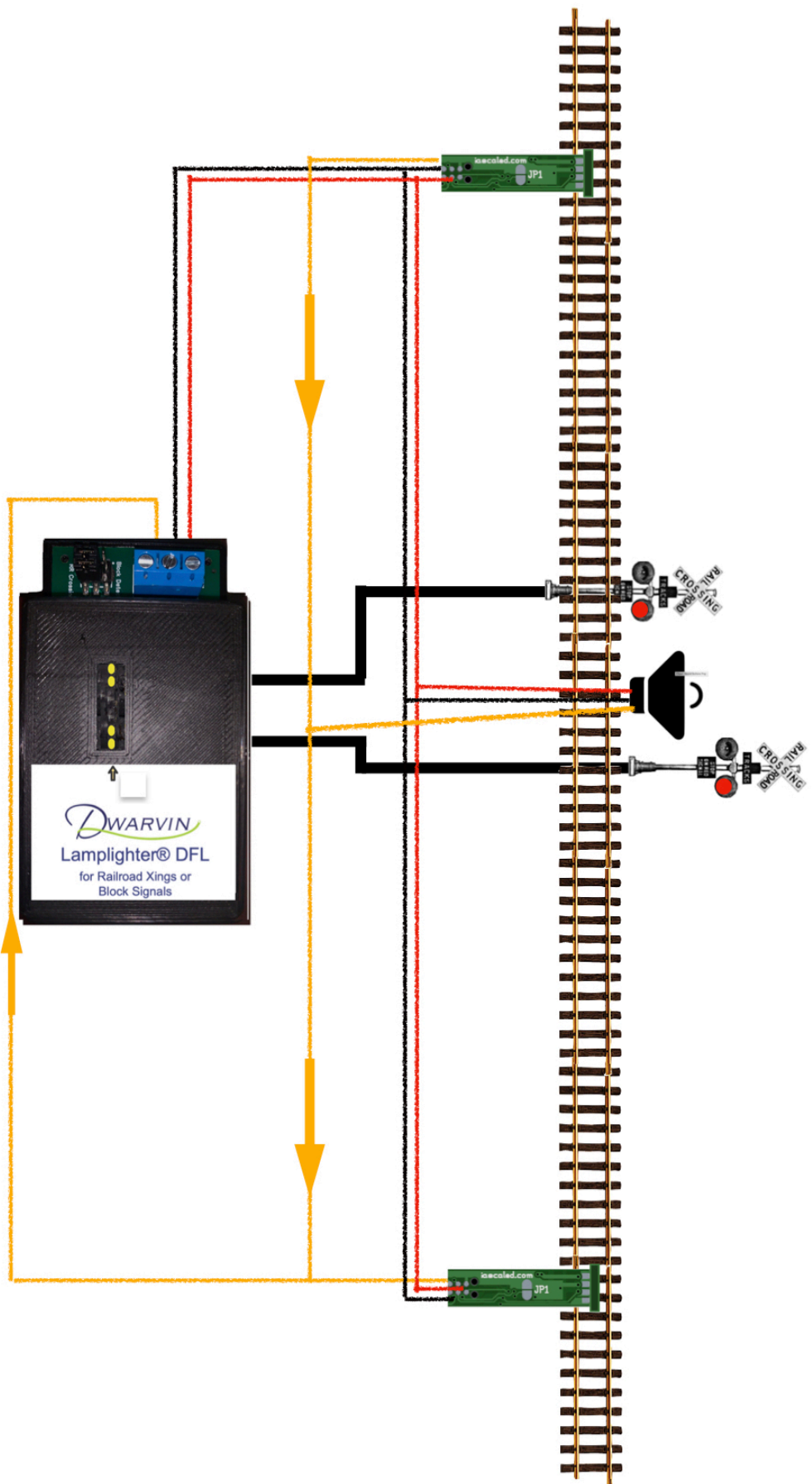

The Detectors

The Detectors come with several extra pieces for mounting.

The **Vertical detectors**, designed to go under the layout, need only the black mounting bracket. It comes with 2 screws, and mounts underneath to where the end-on detector is mounted. There are 2 flanges on this piece designed to gently grab the detector so that it cannot be easily pulled down from it's position under the railroad track.

The **Side-on detectors** come with both the black mounting bracket (+ 2 screws) as well as 2 optional "Electrical" boxes, designed to hide the detector. These mount over the detector allowing the IR sensor to look out through the pill box. These come in two heights. The smaller one positions the detector at 1/2" above the layout surface and the taller one at 13/16th" above the layout surface.

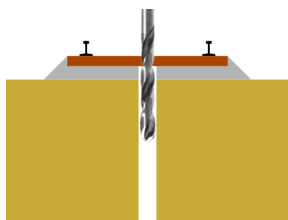
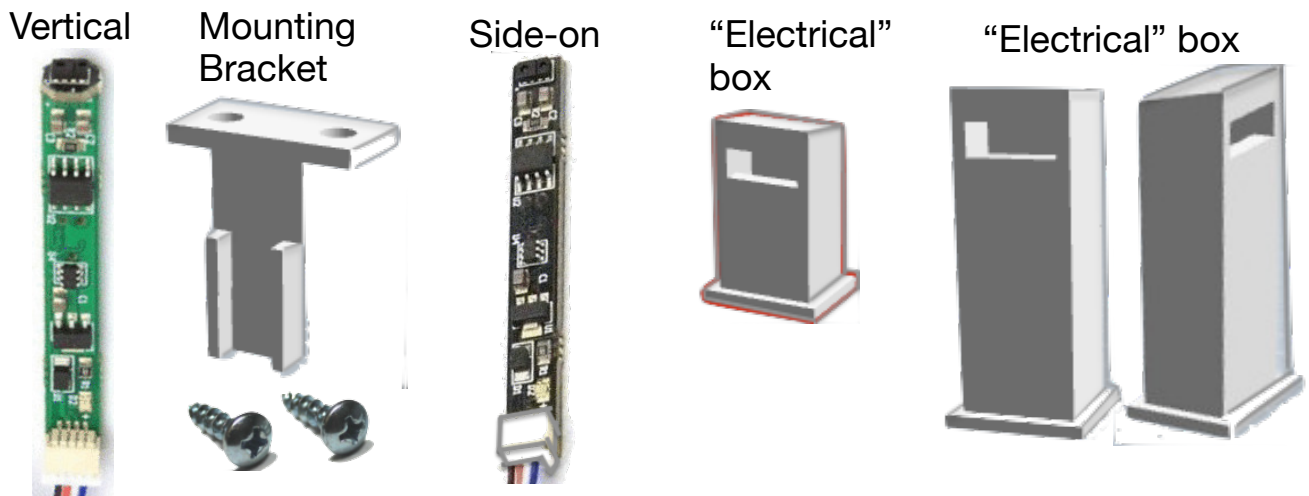

1/16" pilot hole

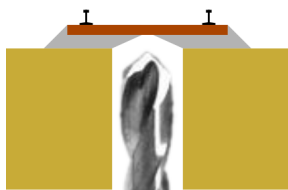

3/8" mounting hole

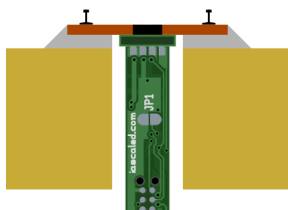

Mounting instructions for Vertical Detectors

Trouble Shooting your DFL Kit:

Detectors:

When activated the very small red LED will come on at the base of the detector.

Problem:

- The red LED does not come on when a train is in front of the detector.

Possible Cause:

- The power is not supplied to the DFL unit and / or the red and black wires from the detectors are not connected properly to the DFL unit.

Action:

- Check this out.

Problem:

- The Red LED stays on all the time even when a train is not in front of the detector.

Possible Cause:

- The detector is seeing something.

Action:

- Adjust the detector (e.g. it may be too low on the layout and is seeing the rail).
-

DFL Unit:

Problem:

- The lights blink continually whether there is a train in front of the detectors or not.

Possible Cause:

- A wire from the black wires for the detectors is connected to the white input on the DFL unit. This will cause the DFL unit to believe the detectors are seeing a train.

Action:

- Disconnect the black wire into the DFL unit to see if the DFL unit stops blinking. If it does there was either a short as noted above or the detector was continually seeing an object.
-

Bell:

Problem:

- The Crossing bell when connected causes the DFL to ring the bell all the time but the Red LED on the detectors is not on.

Possible Cause:

- There is a short between the where the black and white wires enter the DFL unit.

Action:

- Correct this issue as above.

Possible Cause:

- The DFL unit may be defective and may need replacing.

Action:

- Contact Dwarvin Enterprises to trouble shoot further.