

PD16 WIRING DIAGRAM

NOTES

HBO
2 X HALF BRIDGE OUTPUTS

- HIGH/LOW SIDE DRIVE
- 8A MAX CURRENT
- 2kHz SWITCHING SPEED
- OVERCURRENT PROTECTED

RECOMMENDED WIRE GAUGE: 20 AWG

OUTPUT: BATTERY VOLTAGE OR GROUND

8A HCO
10 X 8A HIGH CURRENT OUTPUTS

- HIGH SIDE DRIVE
- 8A MAX CURRENT
- 100Hz SWITCHING SPEED
- CAPABLE OF 0-100% DUTY
- OVERCURRENT PROTECTED
- FLYBACK PROTECTED
- SOFTWARE PROGRAMMABLE FUSE CURRENT
- SOFTWARE PROGRAMMABLE DELAY DURATION ONCE FUSE "BLOWS" BEFORE RETRY
- SOFTWARE PROGRAMMABLE NUMBER OF RETRIES

RECOMMENDED WIRE GAUGE: 18 AWG

• PLUG ALLOWS FOR A LARGER GAUGE WIRE (16AWG) IF REQUIRED

OUTPUT: BATTERY VOLTAGE

SPI
4 X PULSED INPUTS

- -0.5 TO 12V DIGITAL INPUT (VR OR HALL)
- SUPPORTS 0-5V ANALOG VOLTAGE INPUTS
- SELECTABLE 1K PULL-UP TO 5V
- 0 TO 5V THRESHOLD
- -15 TO 30V INDEFINITE WITHSTAND
- 15.9KHZ SIGNAL FREQUENCY (MAX)

RECOMMENDED WIRE GAUGE: 22 AWG

SIGNAL GROUND

- 500mA MAX SINK CURRENT

+5V SENSOR SUPPLY

- 200mA MAX SUPPLY CURRENT

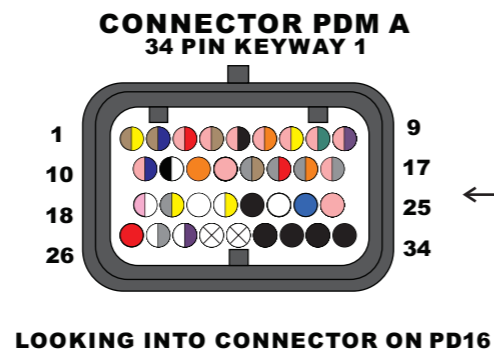
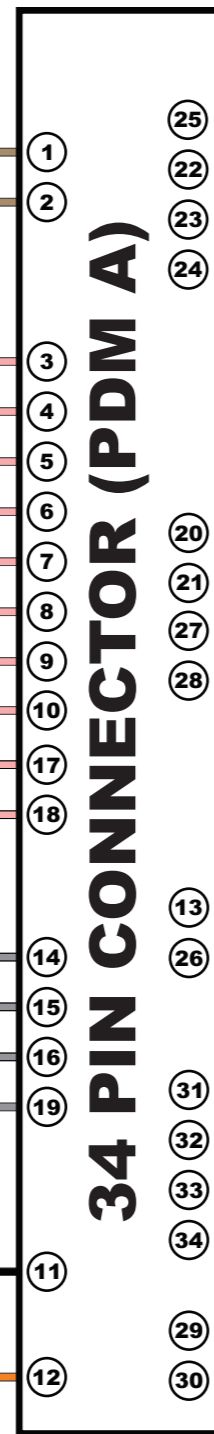
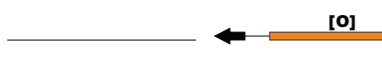
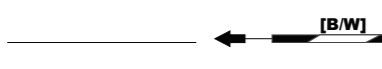
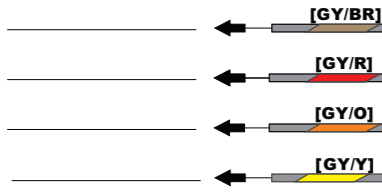
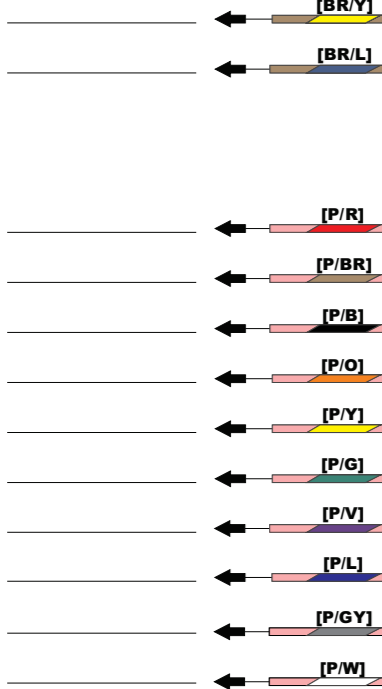

CAN (ISO 11898)
SUPPORTS SPEEDS UP TO 1MBit/s

HALTECH BUS

- SUPPORTS HALTECH EXPANSION PRODUCTS
- PIN 25 CAN BE USED AS AN 8A OUTPUT OR AS THE IGNITION SWITCH INPUT

AVI
4 X ANALOG VOLTAGE INPUTS

- AVI 1 HAS BOTH 1K AND 240R PULL-UP OPTION FOR FUEL TANK SENDERS
- INDIVIDUAL SOFTWARE SELECTABLE 1K PULL-UP TO 5V
- USER DEFINABLE INPUTS CAN BE ALLOCATED TO AVAILABLE FUNCTIONS IN THE SOFTWARE
- -10 TO 30V INDEFINITE WITHSTAND
- 100 SAMPLES/SECOND
- 1.5kHz MAX INPUT FREQUENCY

RECOMMENDED WIRE GAUGE: 22 AWG

INPUT: -10V TO 30V

IGN SWITCH
OUTPUT AND INPUT

CONNECT EACH CONNECTION TO EACH SIDE OF IGNITION SWITCH OR

CONNECT IGN SW INPUT TO ANY SWITCHED 12V SOURCE

MAIN BATTERY GROUND
CONNECT ALL WIRES TO BATTERY NEGATIVE

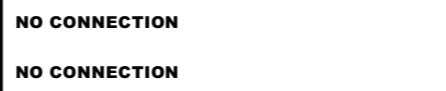
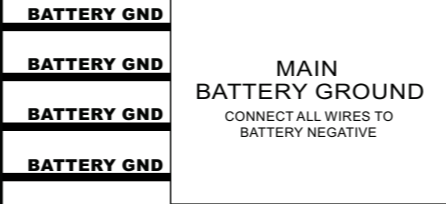
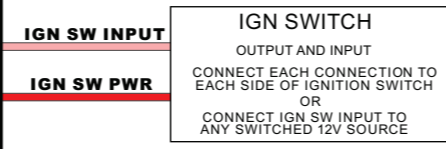
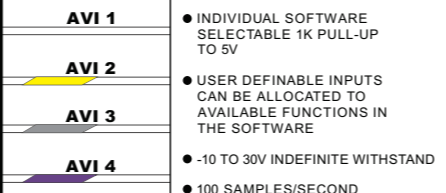

NOTES

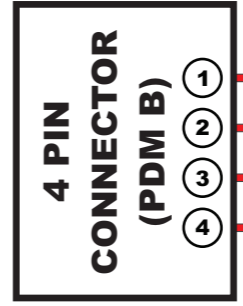
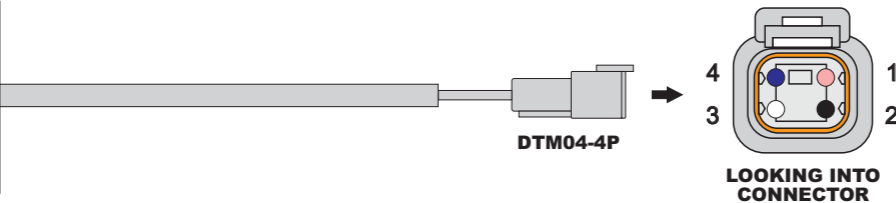

25A HCO
4 X 25A HIGH CURRENT OUTPUTS

- HIGH/LOW SIDE DRIVE
- 25A MAX CURRENT
- CAPABLE OF 0-100% DUTY
- 1kHz SWITCHING SPEED
- SOFTWARE PROGRAMMABLE FUSE CURRENT, DELAY AND NO. OF RETRIES
- OVERCURRENT PROTECTION

RECOMMENDED WIRE GAUGE: 10 AWG

OUTPUT: BATTERY VOLTAGE OR GROUND

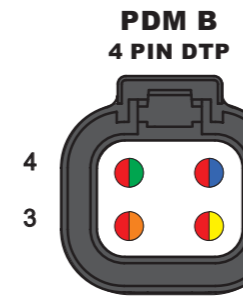

LOOKING INTO CONNECTOR ON PD16

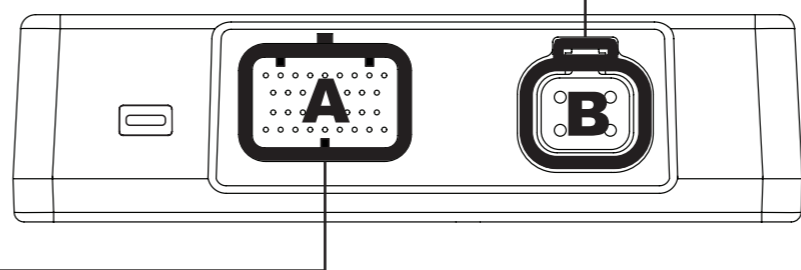

LEGEND - WIRE COLOUR
B = BLACK BR = BROWN G = GREEN GY = GREY L = BLUE
LL = LIGHT BLUE LG = LIGHT GREEN LY = LIGHT YELLOW O = ORANGE
P = PINK R = RED V = VIOLET Y = YELLOW W = WHITE
WHEN TWO COLOURS ARE USED IN A WIRE BY THE ALPHABETICAL CODE, THE FIRST LETTER INDICATES THE BASIC WIRE COLOUR, THE SECOND COLOUR INDICATES THE COLOUR OF THE STRIPE.

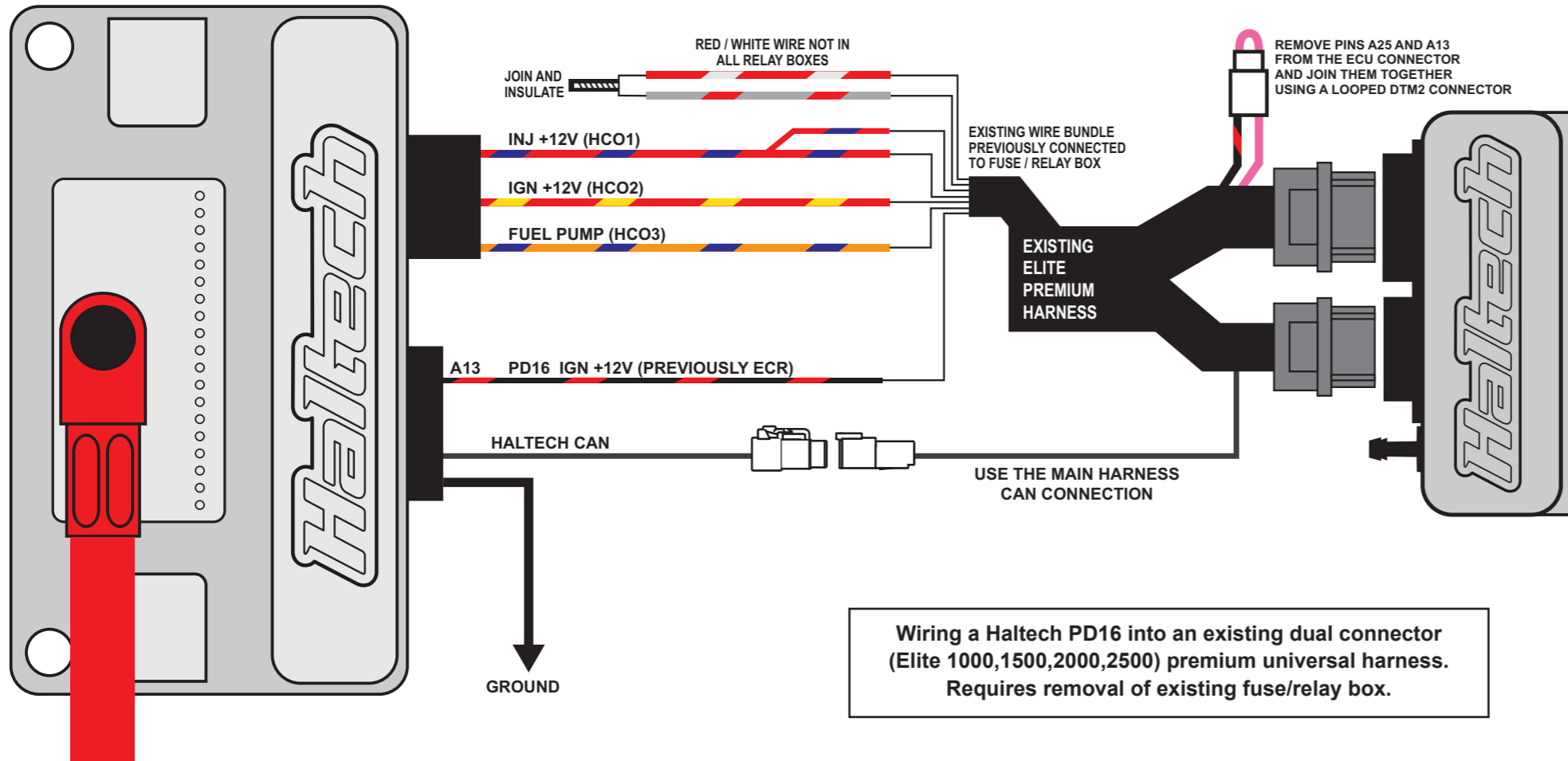

Wiring a Haltech PD16 into an existing dual connector (Elite 1000,1500,2000,2500) premium universal harness. Requires removal of existing fuse/relay box.

Elite 2500 / 2000 / 1500 / 1000 Premium Harness to PD16 Conversion Table

Wire Colour	Relay Number	PDM Connection	Use
Red / White	1 (87)	N/A	Supplies power to ECU Pin B11 and harness auxiliary devices
Grey / Red	1 (87)	N/A	Connect together and insulate (Red / White not in all relay boxes)
Black / Red	1 (85)	IGN SW INPUT	Re-purposed to be ignition input to PD16. Requires ECU pins A25 and A13 to be joined. See the Wiring Diagram
Red / Blue	2 (87)	HCO1	Supplies +12V to ECU and Injectors
Red / Yellow	3 (87)	HCO2	Supplies +12V to Ignition System
Orange / Blue	4 (87)	HCO3	Supplies +12V to Fuel Pump
Red / Green	1 (30)	N/A	No longer used, remove from vehicle, or isolate and insulate. * See Note.
Red	2 (30)	N/A	No longer used, remove from vehicle, or isolate and insulate. * See Note.
Red / White	1 (30)	N/A	No longer used, remove from vehicle, or isolate and insulate. * See Note.

* A new 4AWG wire will be required to run directly from the battery to the PD16 (do not repurpose the red wires above for this, they will not carry enough current for all 16 high side outputs of the PD16)

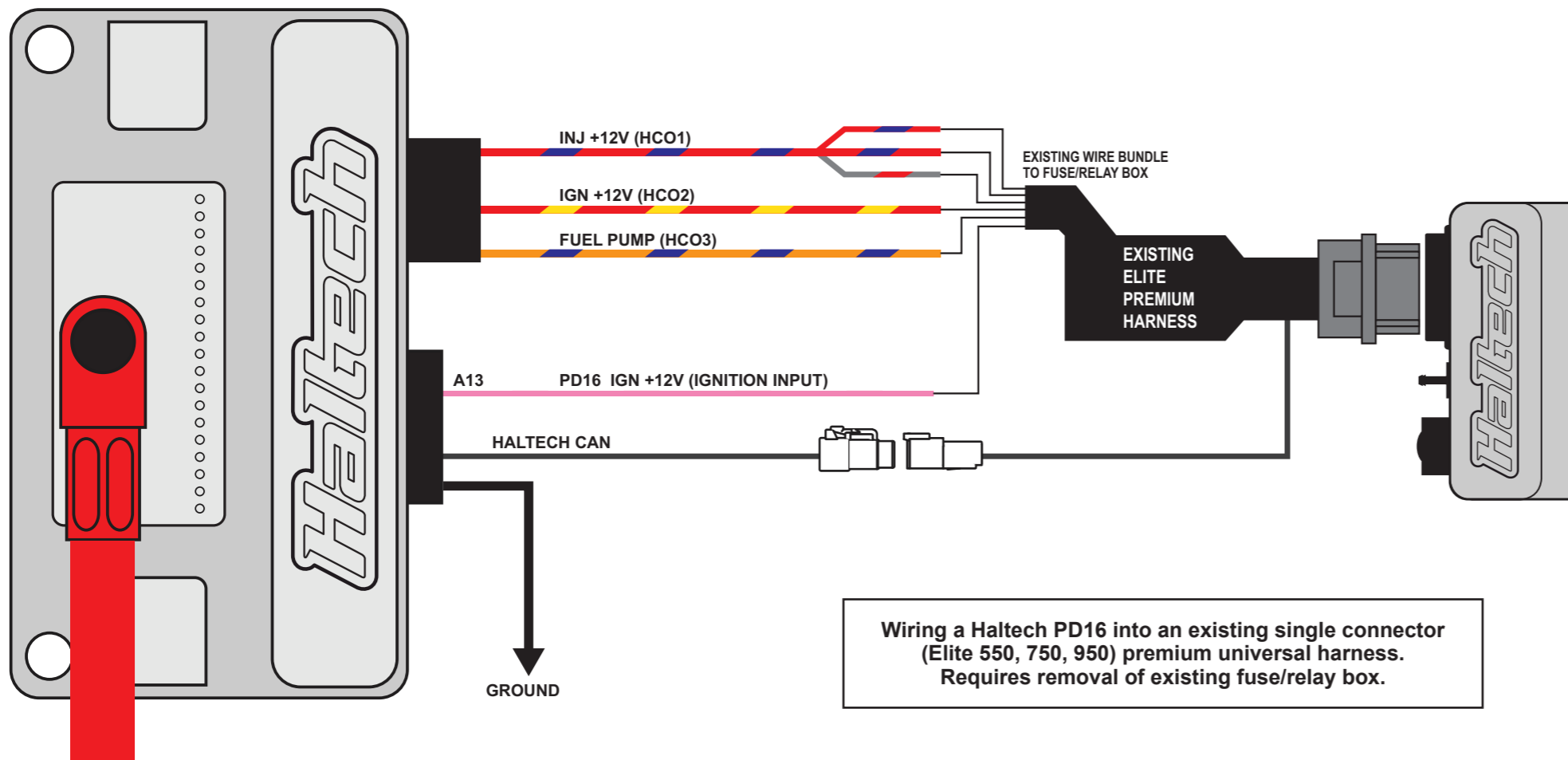
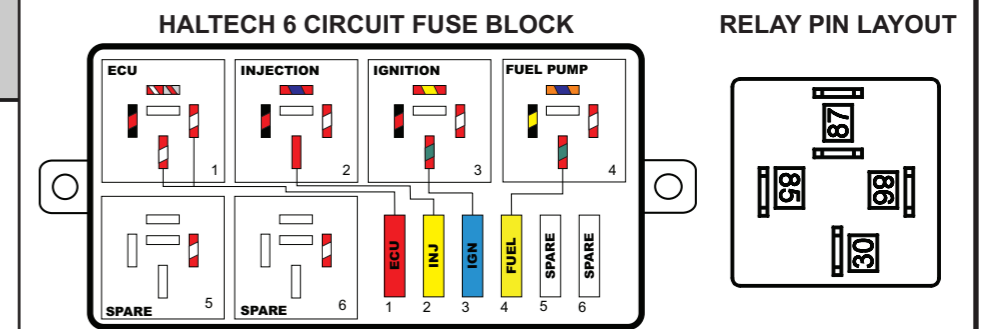

Wiring a Haltech PD16 into an existing single connector (Elite 550, 750, 950) premium universal harness. Requires removal of existing fuse/relay box.

Elite 550/ 750 / 950 Premium Harness to PD16 Conversion Table

Wire Colour	Relay Number	PDM Connection	Use
Red / Blue	1 (87)	HCO1	Supplies +12V to ECU, Injectors and auxiliary devices
Grey / Red	1 (87)	HCO1	Supplies +12V to ECU, Injectors and auxiliary devices
Red / Yellow	1 (87)	HCO2	Supplies +12V to Ignition System
Orange / Blue	2 (87)	HCO3	Supplies +12V to Fuel Pump
Black / Yellow	2 (86)	N/A	Previously the Fuel Pump Relay Control (DPO5) from ECU, this wire can now be re-allocated / used for another function
Red / Green	1 (30)	N/A	No longer used, remove from vehicle, or isolate and insulate. * See Note.
Red	2 (30)	N/A	No longer used, remove from vehicle, or isolate and insulate. * See Note.

* A new 4AWG wire will be required to run directly from the battery to the PD16 (do not repurpose the red wires above for this, they will not carry enough current for all 16 high side outputs of the PD16)

