

3-Axis Ultrasonic Anemometer

Key Features

- Precision 3-axis sonic anemometer
- 20Hz output rate
- 0-50m/s wind speed
- 0-359° wind direction
- U, V, W vector outputs
- Sonic temperature output
- Aluminium/Carbon fibre construction
- Optional custom calibration

The Gill WindMaster is a precision anemometer offering three-axis wind measurement data. This instrument will monitor wind speeds of 0-50m/s and provides sonic temperature, speed of sound and U, V & W vector outputs at 20Hz (32Hz optional). This anemometer is of aluminium/carbon fibre construction and is ideal for the understanding of turbulent flows, surface energy balance and scalar fluxes. Each WindMaster can be calibrated with an optional Gill wind tunnel test to provide optimum performance.

This 3D sonic anemometer is ideally suited to the measurement of air turbulence around bridges, buildings, wind turbine sites, building ventilation control systems, meteorological and flux measurement sites.

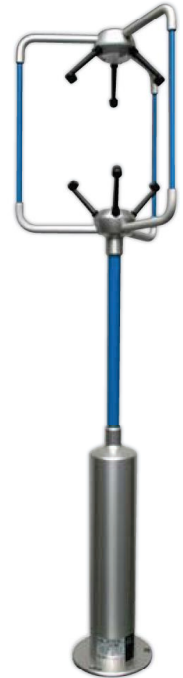

WIND SPEED

Range	0 - 50 m/s
Resolution	0.01 m/s
Accuracy*	<1.5% RMS @12 m/s
Accuracy*	<1% RMS @12 m/s (Custom)

DIRECTION

Range	0 - 359°
Resolution	0.1°
Accuracy	2° @12 m/s
Accuracy	0.5° @12 m/s (Custom)

SONIC TEMPERATURE

Range	-40°C to +70°C
Resolution	0.01°C
Accuracy	-20°C to +30°C within ±2°C of ambient temperature

SPEED OF SOUND

Range	300-370 m/s
Resolution	0.01 m/s
Accuracy	< ±0.5% @ 20°C

MEASUREMENT

Internal sample rate	20 Hz or 32 Hz
Output Parameters	1, 2, 4, 8, 10, 16, 20 & 32 (Option) Hz
Units of Measure	m/s, mph, kph, knots, ft/min
Formats	UVW or Polar

DIGITAL OUTPUT

Communication	RS232, 422, 485, Binary
Baud Rates	2400 - 57600
Format	ASCII

ANALOGUE OUTPUTS - OPTIONAL

Resolution 12 bits or 14 bits	4 channels available
Selectable Range	User selectable full scale wind speed
Output type	0-20mA, 4-20mA, 0-5V, ±2.5V, ±5V

ANALOGUE INPUTS - OPTIONAL

Resolution 12 bits or 14 bits	Up to 4 single ended or 2 differential
Input Type	±5V

POWER REQUIREMENT

Anemometer	9-30 VDC (55mA @ 12 VDC)
------------	--------------------------

MECHANICAL

Weight	1.0 kg
Size	750mm x 240mm

ENVIRONMENTAL

Protection Class	IP65
Operating Temp	-40°C to +70°C
Humidity	< 5% to 100% RH
Precipitation	300mm/hr
EMC	BS EN 61000 - 6 - 3 (Emissions) BS EN 61000 - 6 - 2 (Immunity)

*Accuracy spec applies for wind speed, and for wind incidence up to ±30° from the horizontal

Typical Applications

- Power Lines
- Bridges
- Viaducts
- Building ventilation control systems
- Measurement Masts
- Skyscrapers
- Wind Turbine Test Sites
- Meteorological & Flux measurement sites

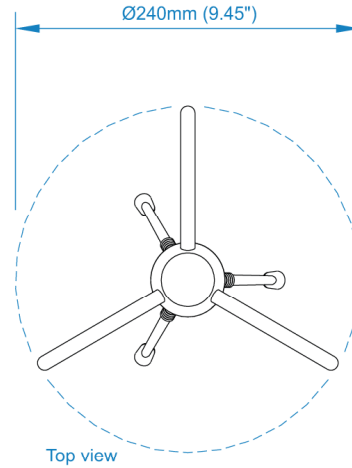
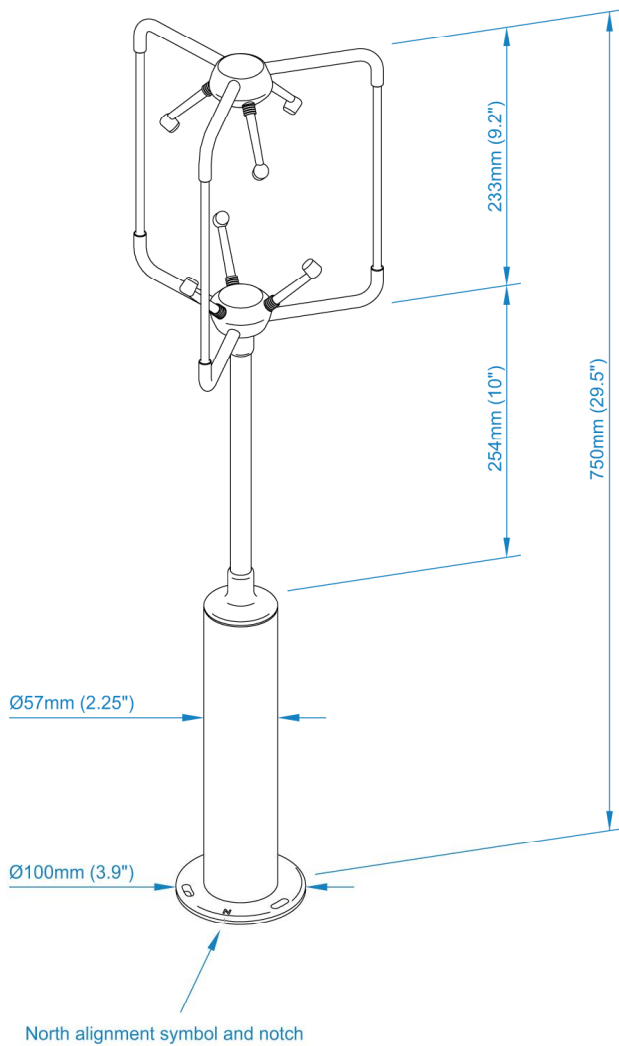

Top view

Positions for three off bolt fixings with $\varnothing 7.0\text{mm}$ (0.27") max. thread, on a p.c.d. of 85mm (3.35")

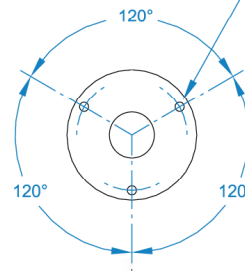

Pipe Mount 34 mm (1.34 in) diameter (standard 1 inch pipe) option with Terminal Strip Junction Box



This product is in continuous development and therefore specifications may be subject to change without prior notice.

skyview
the weather company

Skyview Systems Ltd.
Skyview Centre, 9 Churchfield Road,
Chilton Industrial Estate,
Sudbury, Suffolk. CO10 2YA. (UK)

Tel: +44 (0)1787 883138
Fax: +44 (0)1787 883139
email: systems@skyview.co.uk
web: www.skyview-systems.co.uk