

## Key Features

- 3-axis research anemometer
- 50Hz output rate
- 0-45 m/s wind speed
- 0-359° wind direction
- U, V, W vector outputs
- Sonic temperature output
- Aluminium/carbon fibre construction
- Custom calibration provided as standard

The R3-50™ 3-axis anemometer has been designed for scientific research, particularly suitable for determining fluxes using the eddy covariance technique. This precision ultrasonic anemometer will monitor wind speeds up to 45m/s, with a fast data output rate of 50Hz. U, V, W and SOS (sonic temperature) outputs are available, and data can be logged using the supplied Gill WindCom™ software.

The R3-50 is of aluminium/carbon fibre construction and will operate effectively in environmental temperatures from -40°C to +60°C. Optional accessories are available including cables, sensor input units (analogue inputs) and power supplies.



### WIND SPEED

Range	0 - 45 m/s
Resolution	0.01 m/s
Accuracy	<1% RMS

### DIRECTION

Range	0 - 359°
Resolution	1°
Accuracy*	<±1° RMS

### SPEED OF SOUND

Range	300-370 m/s
Resolution	0.01 m/s
Accuracy	< ±0.5% @ 20°C

### MEASUREMENT

Ultrasonic output rate	50 Hz
Parameters	UVW, Speed of Sound

### DIGITAL OUTPUT

Communication	RS422 full duplex, 8 data bits, 1 stop bit, no parity
Baud rates	2400 - 115200
Output parameters	Selectable 0.4 to 50 Hz

### PRT INPUT

Input resolution	0.01°C
Input accuracy	<0.01°C (0°C to +50°C) <0.15°C (-40°C to +60°C)

\*Accuracy spec applies for wind speed <32 m/s and for wind incidence up to ±20° from the horizontal

### ANALOGUE OUTPUTS (REQUIRES PCIA UNIT)

Quantity	7 (U, V, W, SoS, PRT plus 2 analogue outputs)
Scale	±10, ±20, ±30, ±60 m/s
Update rate	0.4 to 50 Hz
Range and resolution	±2.5V, 14 bits
Accuracy	<0.1% of FSR

### ANALOGUE INPUTS (REQUIRES SIU)

Quantity	6 differential inputs
Sampling rate	50 Hz
Range and resolution	±5V, 14 bits
Accuracy	<0.1% of FSR

### POWER REQUIREMENT

Anemometer	9-30 VDC (<150mA @ 24 VDC or 300mA @ 12 VDC)
------------	--

### MECHANICAL

Material	Aluminium/Carbon Fibre
Size	750mm x 240mm
Weight	1.0 kg

### ENVIRONMENTAL

Protection Class	IP65
Operating Temp	-40°C to +60°C
Precipitation	300mm/hr
EMC	BS EN 50081-1: 1992 (Emissions) BS EN 50082-1: 1997 (Immunity)
Suitable for exposure to a marine environment	

## Typical Applications

- Wind Turbulence Measurement
- Component Wind Velocity UVW
- Wind Profiling

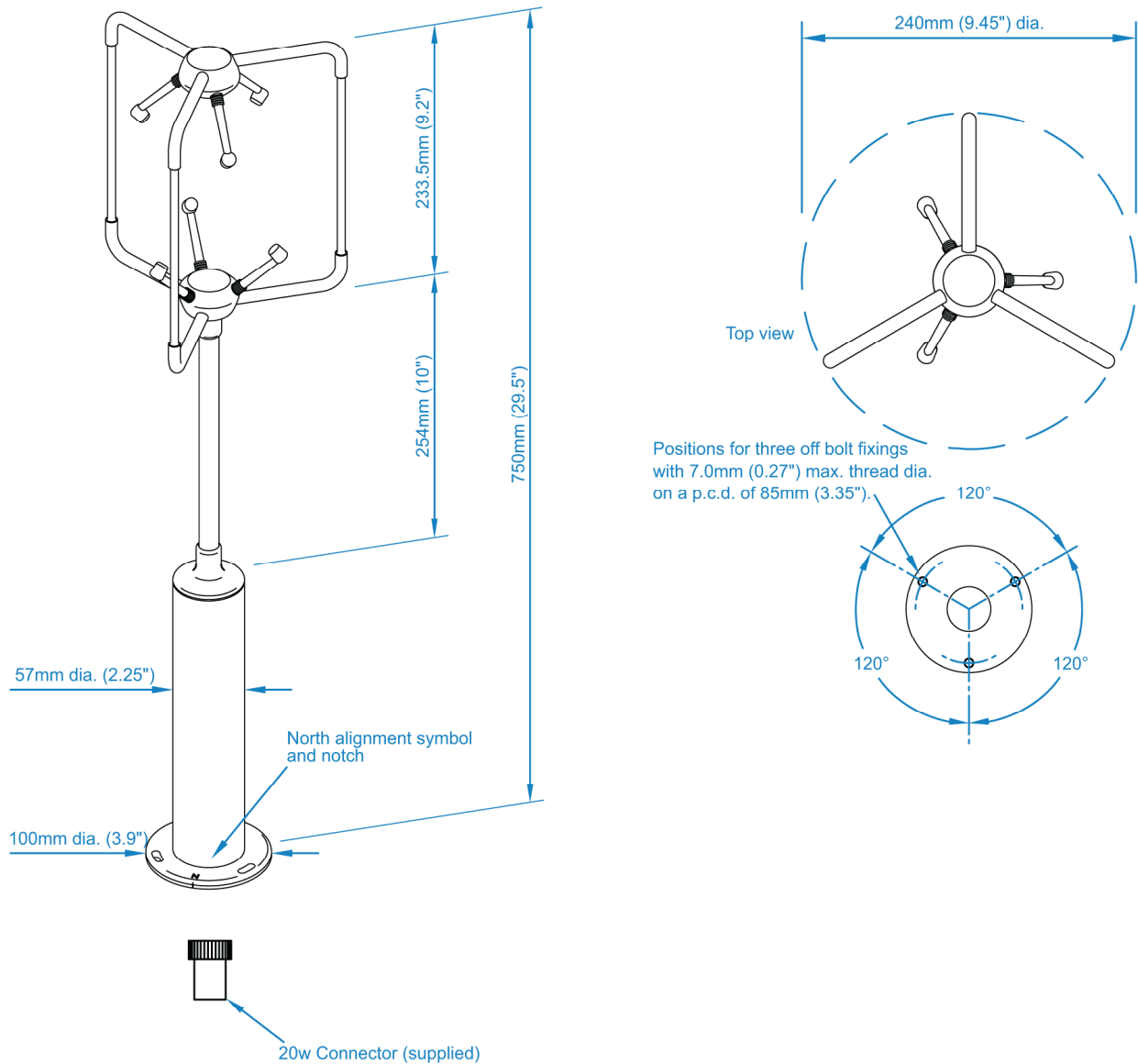

Specifications may be subject to change without prior notice.

# skyview

the **weather** company

Skyview Systems Ltd.  
 Skyview Centre, 9 Churchfield Road,  
 Chilton Industrial Estate,  
 Sudbury, Suffolk. CO10 2YA. (UK)

Tel: +44 (0)1787 883138  
 Fax: +44 (0)1787 883139  
 email: [systems@skyview.co.uk](mailto:systems@skyview.co.uk)  
 web: [www.skyview-systems.co.uk](http://www.skyview-systems.co.uk)