

TITAN FH5 HD 机架组装示意图

Frame Assembly Guide for TITAN FH5 HD



采用全新的设计和结构,区别于以往的产品更为优秀。TITAN FH5机架采用高质量3K碳纤维板,前后一体化机臂提升强度的同时带来更加干净简洁的机身设计,与飞机一同设计的专属3D打印件提高了有效的低速碰撞保护的同时还拥有了不错的颜值。采用中置天空端悬吊式设计,使飞机的重心更加平衡,同时提供优秀的飞行性能及操控手感。

The TITAN DC5 HD frame is designed for the DJI FPV system, with custom camera side plates, TPU print bracket for DJI FPV Air Unit and antennas. The carbon fiber camera plates plus TPU print inserts provides the best mounting solution for your DJI camera. And the TPU print bracket is specially designed for the DJI Air Module, making it is easier to mount into the TITAN DC5 frame. The TPU print part provided for SMA mount making installation very easy. With boomerang arms and the way to mount the DJI unit and Stack centered to have optimized weight distribution.

技术规格

Specifications

对角轴距:	222mm	安装高度:	35mm
整体框架尺寸:	220*190mm (L x W)	飞控孔距:	30.5*30.5mm/20mm*20mm
空机重量:	131g (包括打印件)	电机卡簧孔位:	8mm
底板厚度:	3mm	电机:	22\23系列电机
顶板厚度:	2.5mm	摄像头间距:	20mm
机臂宽度:	10mm		











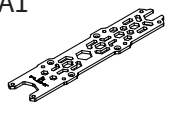
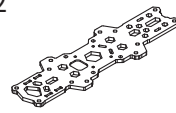
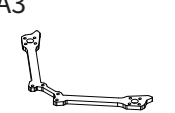
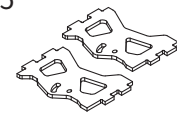
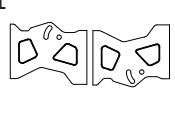
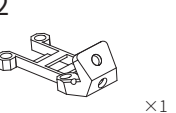
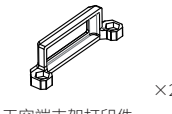
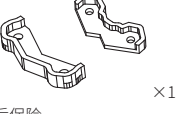
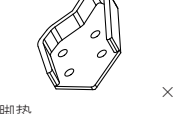

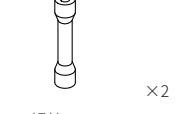
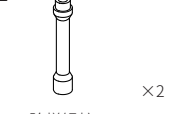
Wheelbase:	222mm	Install height:	35mm
Dimensions:	220*190mm (L x W)	FC mounting:	30.5*30.5mm/20mm*20mm
Weight:	131g (Including TPU weight)	Motor base hole OD:	8mm
Bottom plate thickness:	3mm	Motor:	22xx/23xx
Top plate thickness:	2.5mm	Camera distance:	20mm
Arm width:	10mm		

物品清单

In the Box

使用本产品前,请检查产品包装内是否包含以下所有物品。若有缺失,请联系iFlight或您的代理商。

Check that all of the following items are in your package. If any item is missing, contact iFlight or your local dealer.

A1  顶板 TOP plate ×1	A2  底板 Bottom plate ×1	A3  前后机臂 Front Rear arm ×2	A5  侧板 Camera plate ×2	B1  侧板打印件 TPU print for side plate ×2	B2  SMA 天线支架 SMA Antenna bracket ×1
B3  天空端支架打印件 DJI AIR Unit bracket ×2	B4  前后保险 Front and after insurance ×1	B5  脚垫 Foot pad ×4	B6  TBS crossfire 支架 TBS crossfire Mount ×1	C1  M3X35 铝柱 M3X35 Alum standoff ×2	C2  M3X35 阶梯铝柱 M3X35 ladder Alum standoff ×2
C3  M3X30 铝柱 M3X30 Alum standoff ×2	D1  M3X8 沉头内六角螺丝 M3X8 Countersunk hex screw ×4	D2  M3X8 内六角螺丝 M3X8 hex screw ×16	D3  M3X12 内六角螺丝 M3X12 hex screw ×4	D4  M3X20 内六角螺丝 M3X20 hex screw ×4	D5  M2X5 内六角螺丝 M2X5 hex screw ×4
E1  M3尼龙螺母 M3 Nylon nut ×12	E2  电池扎带 Battery strap ×2	E3  电池防滑垫 Battery Anti-skid Pad ×1			

安装步骤

Assembly Instructions



安装所需的各个部件可根据编号在物品清单标示的对应位置中找到。

Each item has code. Refer to the In the Box section and check the corresponding code to find out where each item is located in the package.

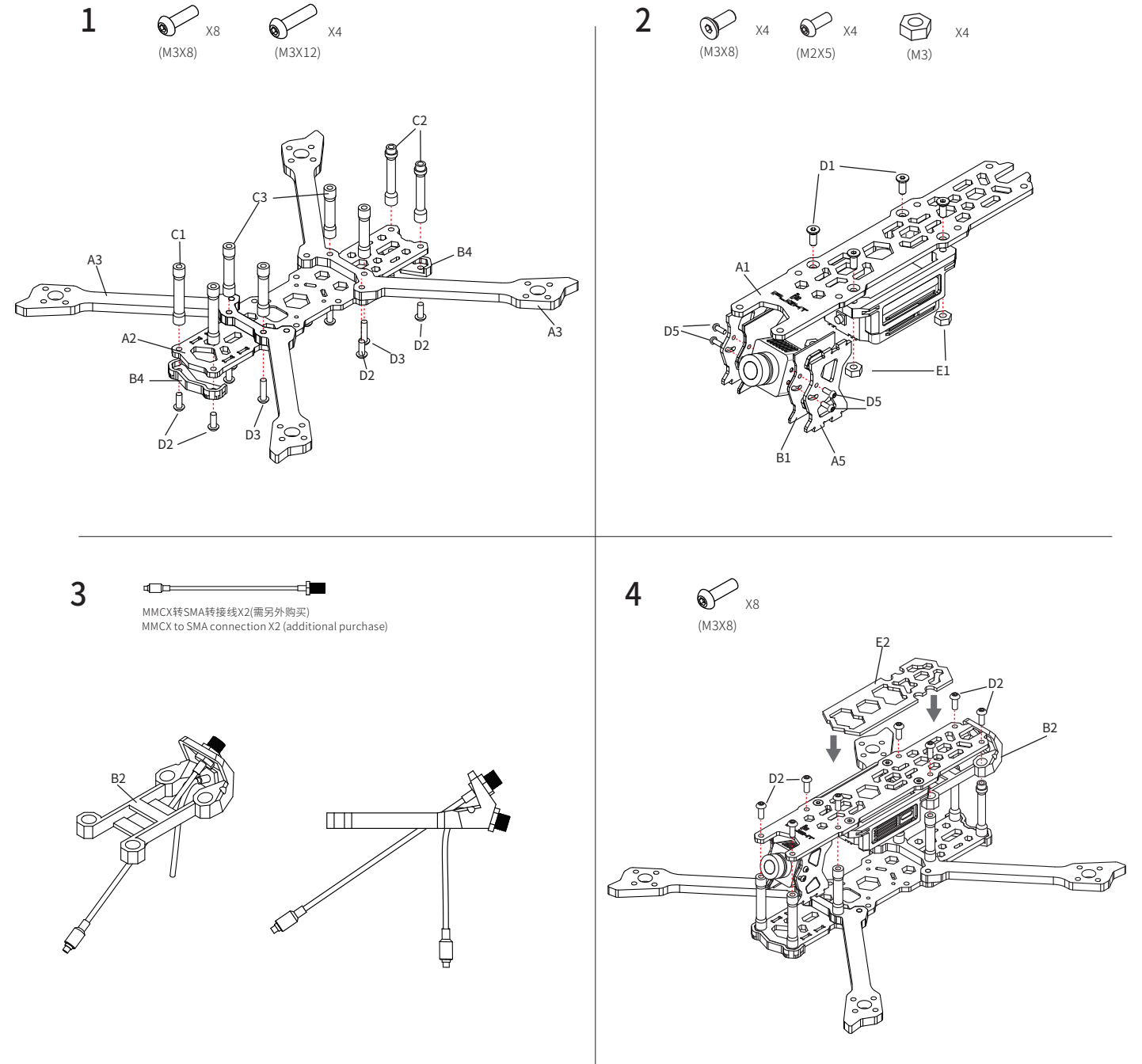

内容如果更新,恕不另行通知。

了解产品详细信息,请访问iFlight官网产品界面

The content is subject to change without prior notice

Visit the product page on the official iFlight website for more information

<http://www.iflight-rc.com>