



SABAI

SABAI Welcome to the Sabai Family!

Let's get cozy.

We're so glad you've joined the party!

Sabai means “comfy,” “relaxed,” and “easy” in Thai. We want you to feel that way about both our products and your experience with us, from start to finish.

Let's get friendly.

You can lounge easy knowing we've worked hard to minimize your sofa's impact on the environment.

Our Packaging:

As you unpack your sofa, you'll notice that our packaging does not use any plastic.

Our Frames:

FSC certified wood.

Our Cushions:

CertiPUR-US certified foam.

Our Pillows:

Recycled fiber.

Our Fabric:

We offer a selection of recycled, upcycled, and natural fiber fabrics.

Our Closed Loop Promise

Furniture is the least recycled household item, with over 80% ending up in landfills. To ensure our sofas do not meet the same fate, we guarantee that we will buy any sofa back within 3 years at 20% of the retail price.

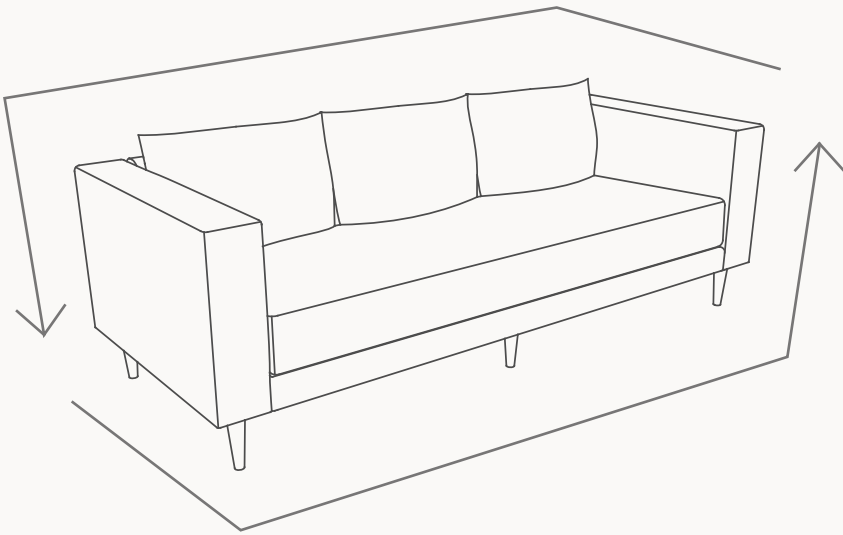

Get ready to lounge!

The Essential Sofa: Components

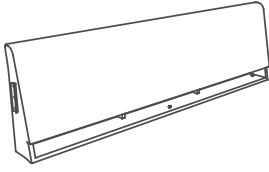

Sofa Back (A)

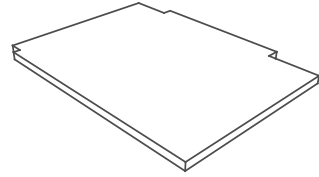

Platform (G)

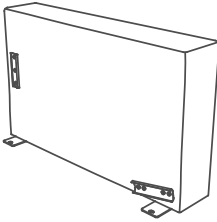

Right Arm (B)

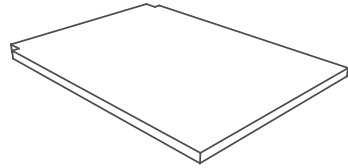

Platform (H)

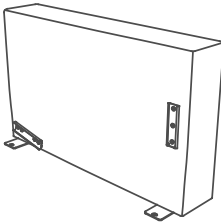

Left Arm (C)

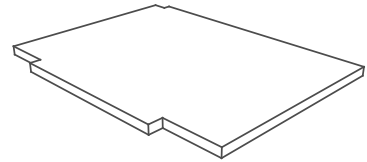

Platform (I)

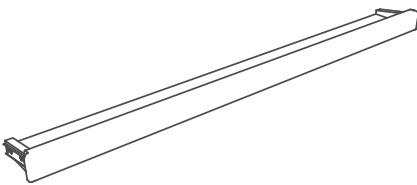

Front Rail (D)

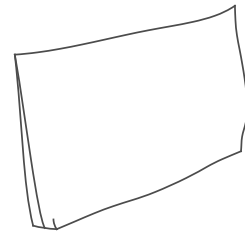

Pillows (K x 3)



Bench
Cushion (J)

OR

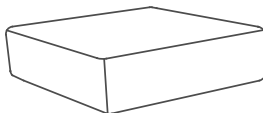

Single Cushion (L x 3)

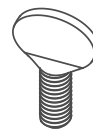

Thumb
Bolts (E x 4)



Legs (F x 6)

How To Assemble: The Essential Sofa

1. Lay Back (A) on its back. Lay Right Arm (B) to the right and Left Arm (C) to the left of Back (A) on their backs. Slide each arm along and against Back (A) so that the bracket on the inside of each arm slides into the bracket on the sides of the back. Make sure to keep the arms at a 90° angle so that the brackets line up.

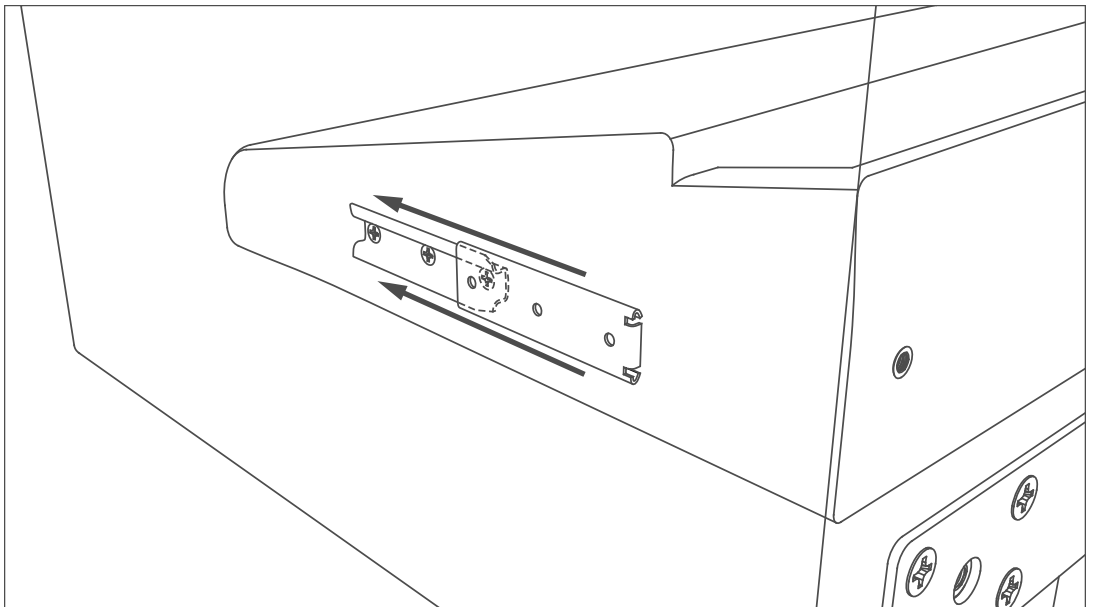
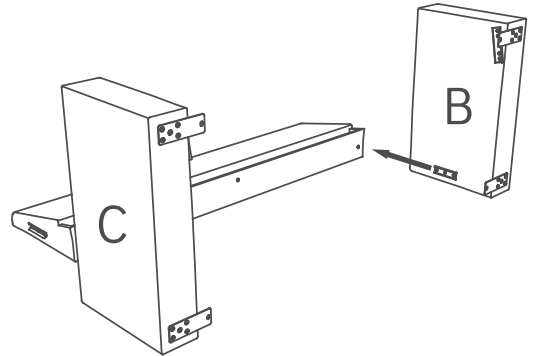

2. Slide the Front Rail (D) into the front brackets of each arm. Make sure to line both sides up before fully sliding it in.

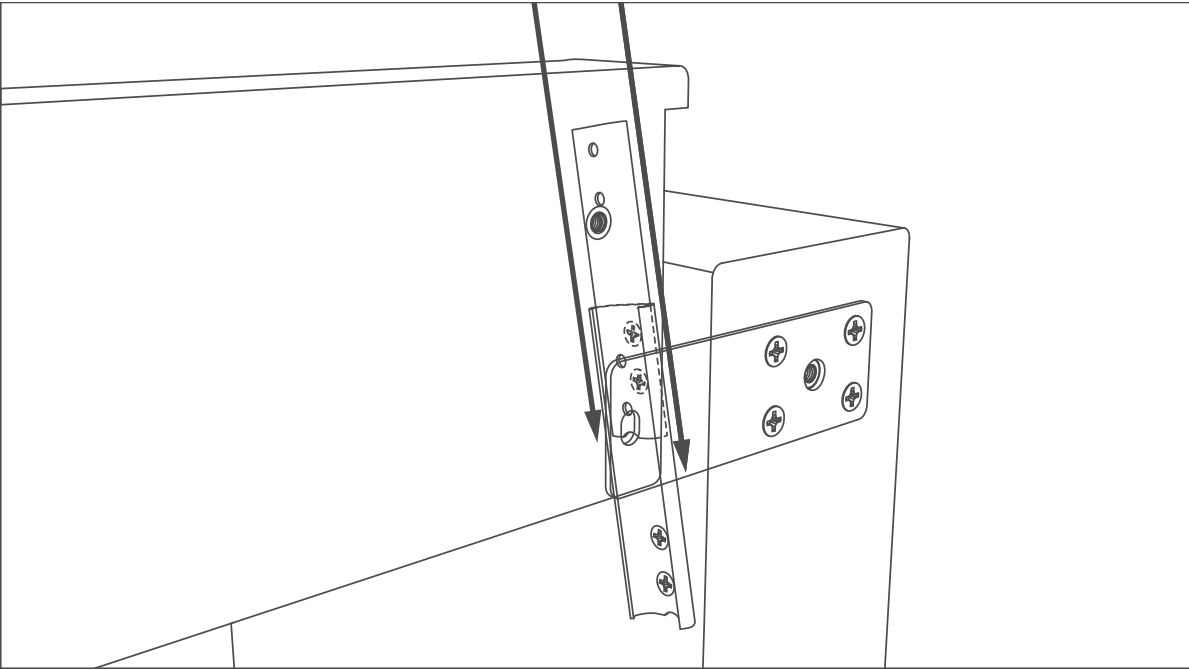
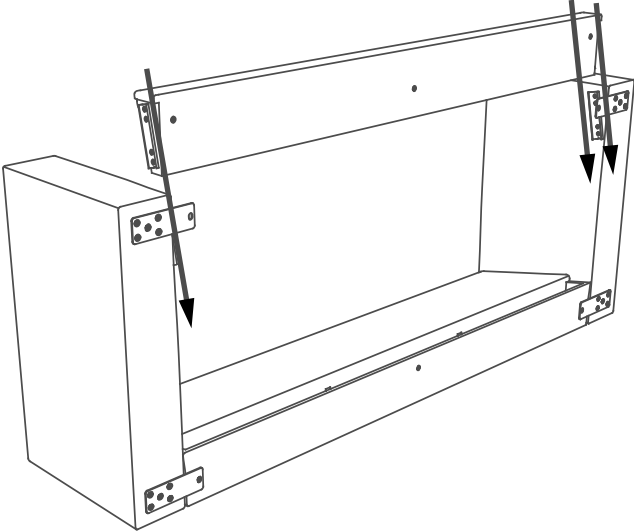

3. Flip the sofa over. Line the rectangular Base Plates up with the holes located on the Back (A) and Front Rail (D). Screw Thumb Bolts (E) into the holes clockwise until tight against the plates.

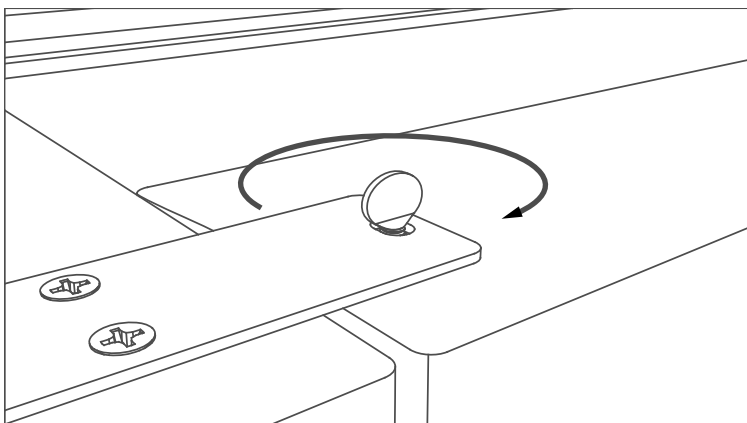
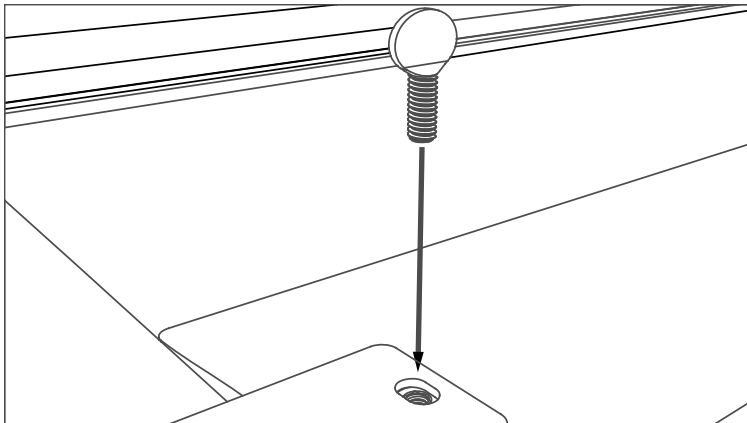
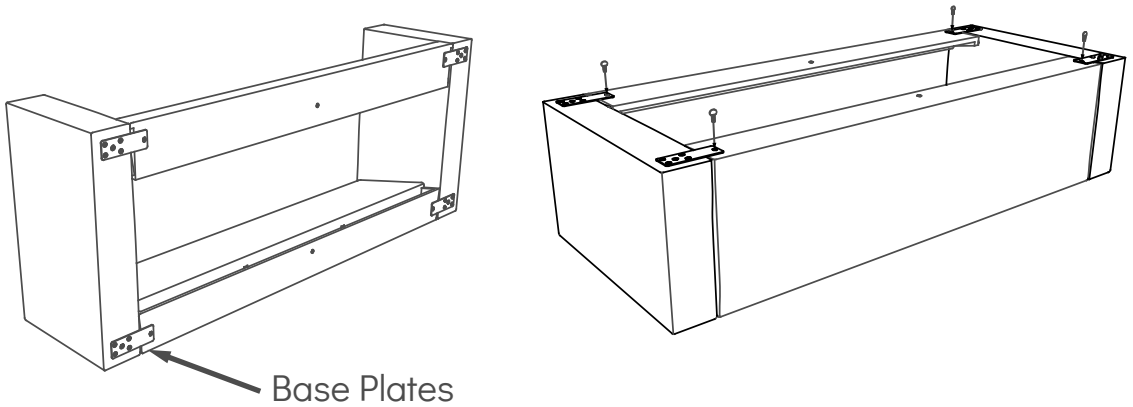

4. Screw all 6 Legs (F) into the holes as indicated.

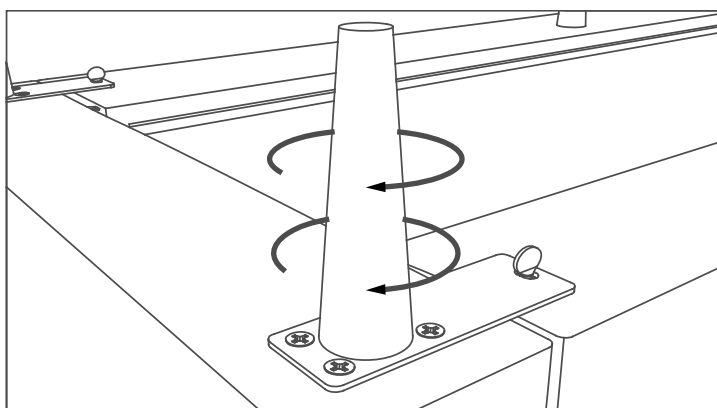
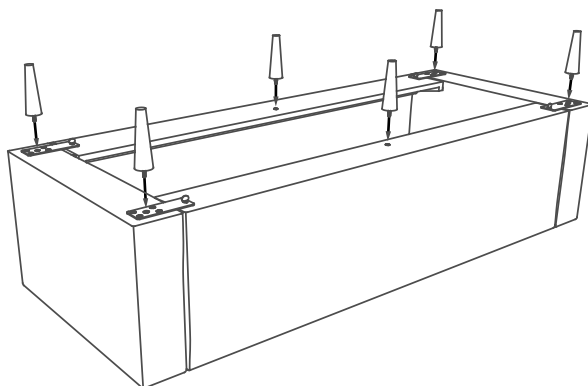

5. Flip the couch right side up.

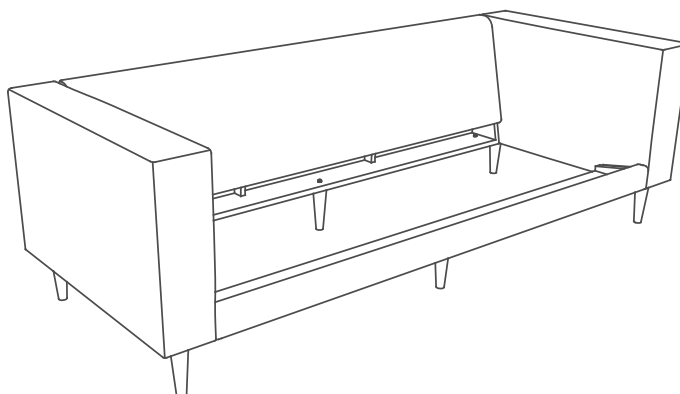

6. Lay Platforms (G), (H) and (I) across the Back (A) and Front Rail (D). When facing the front of the sofa, Platform (G) goes on the right, (H) in the middle, and (I) on the left side. Platforms should lay at an angle, slightly raised in the front resting on the black strip running across the front rail.

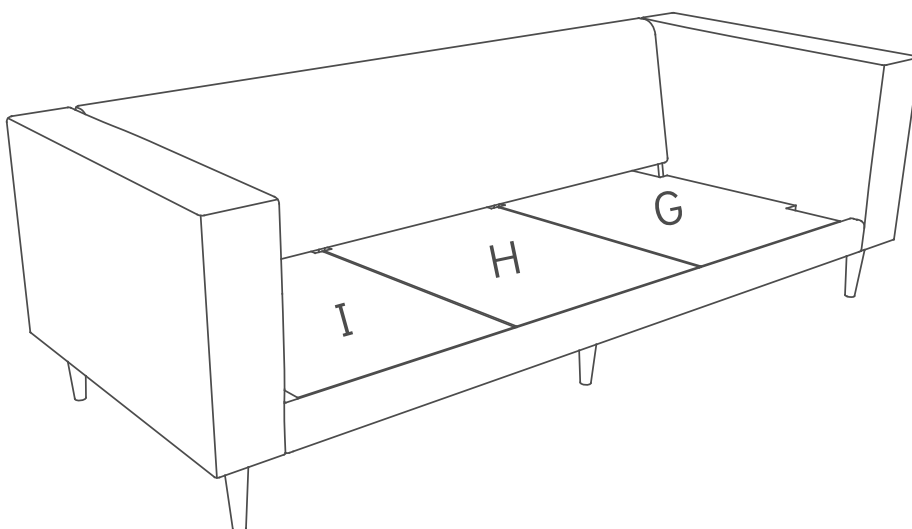
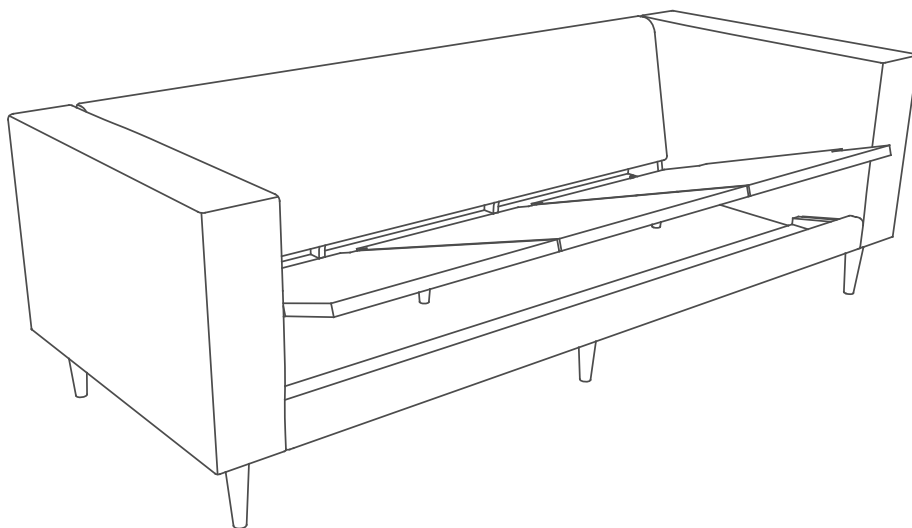

For Single Seat Cushions:

7. Place the Single Cushions (L) over the Platforms.

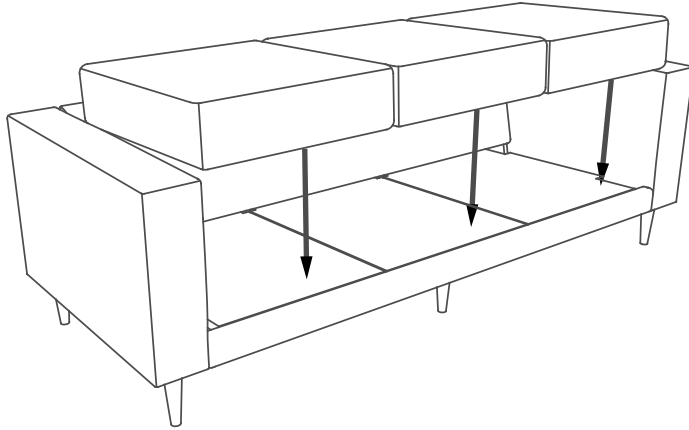

8. Put each back pillow insert into a cover and place them against the Back (A).

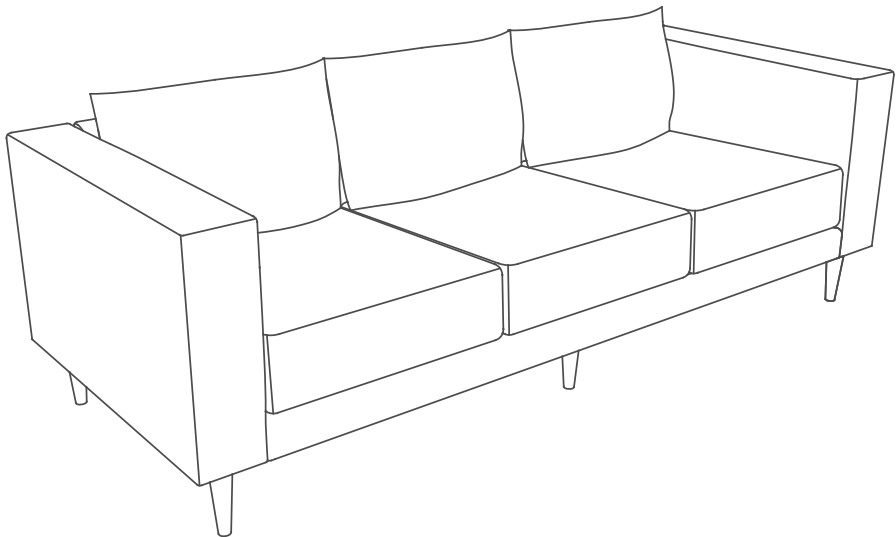

For Bench Cushions:

7. Put the fabric cover over the Bench Cushion (J) and place it over the platforms.

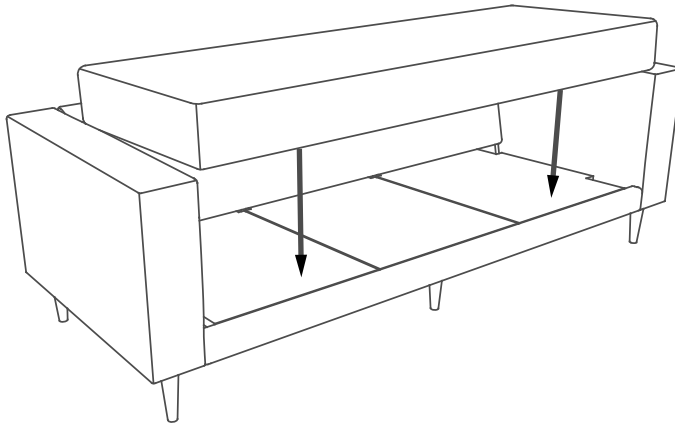

8. Put each back pillow insert into a cover and place them against the Back (A).

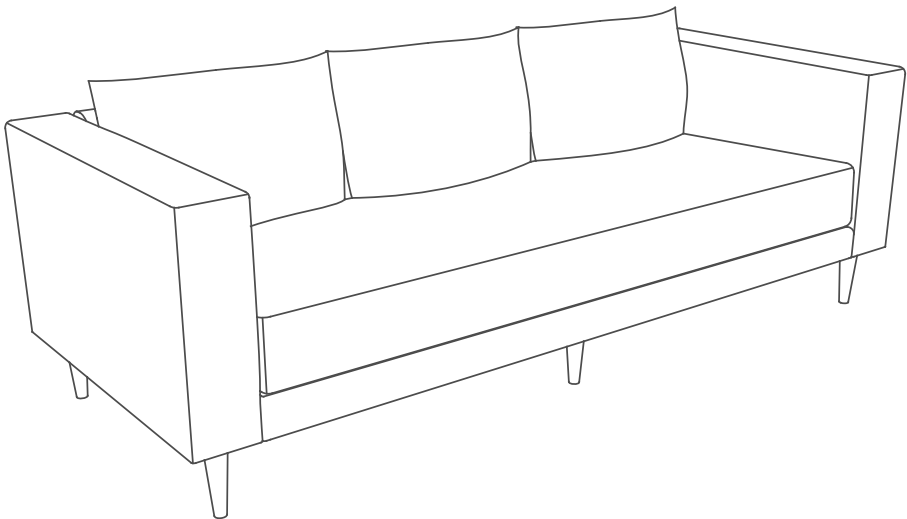

SABAI

Where to find us:

 [sabai.design](#)

 [sabai.design](#)

Questions or concerns?

general@sabai.design