

SABAI

Designing the Difference

THE ELEVATE SOFA

Welcome to Sabai

Sabai is designing the difference.

We've minimized your furniture's impact on the environment, from the materials, to the manufacturing process, to programs to extend its life cycle.

Our products are 100% vegan and are made from a combination of recycled, upcycled, and biodegradable materials.

We utilize mechanical fasteners (rather than glue) to ensure that our materials remain recyclable and that we are keeping our manufacturing team safe.

To make sure our furniture stays out of landfills, we've launched two programs under our Sabai Standard: The Repair Don't Replace and Sabai Revive resale programs.

After a simple assembly, you can rest easy with Sabai.

This guide makes assembly a cinch. If you still have questions, you can reach our customer service team at customer@sabai.design and we'll respond within 24 hours.

Components

ARMS X 2

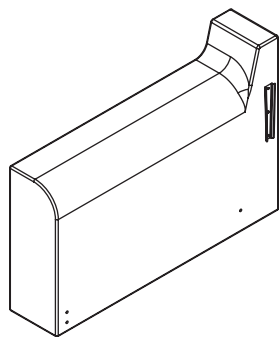

LEFT ARM

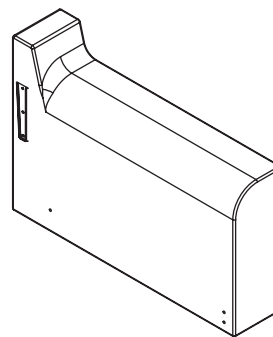

RIGHT ARM

BACKS X 2

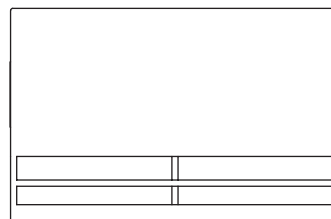
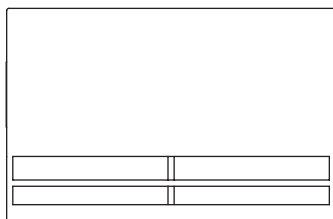

FRONT RAIL

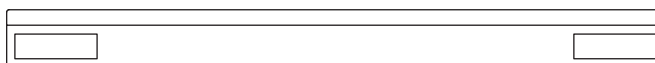

PLATFORMS X 2

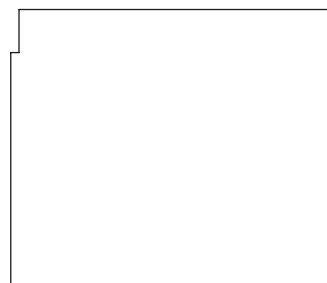

Components

SEAT CUSHION

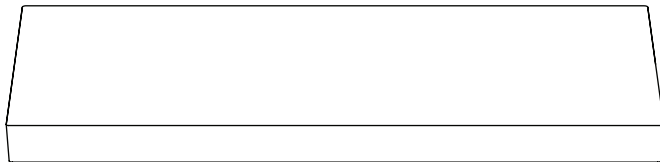

BACK PILLOWS X 2

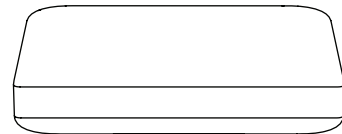
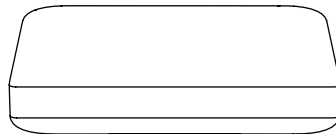

LEGS X 8 SQUARE LEG X 1 CENTER LEG

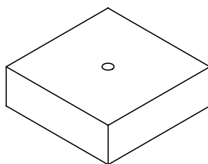

SQUARE LEG

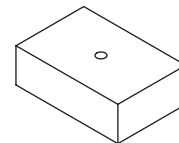

CENTER LEG

RATCHET WRENCH

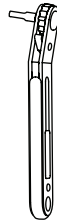

METAL BOLTS X 15

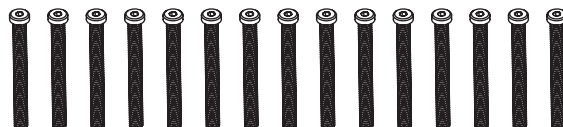

Note: The listed bolt quantity reflects how many bolts are needed for assembly, but you have been provided with extra bolts just in case they're needed.

1 Attach Backs to Arms

- A** Take one Back and the right Arm and align the brackets on both pieces. Slide the Back down to line up with the bottom of the Arm.

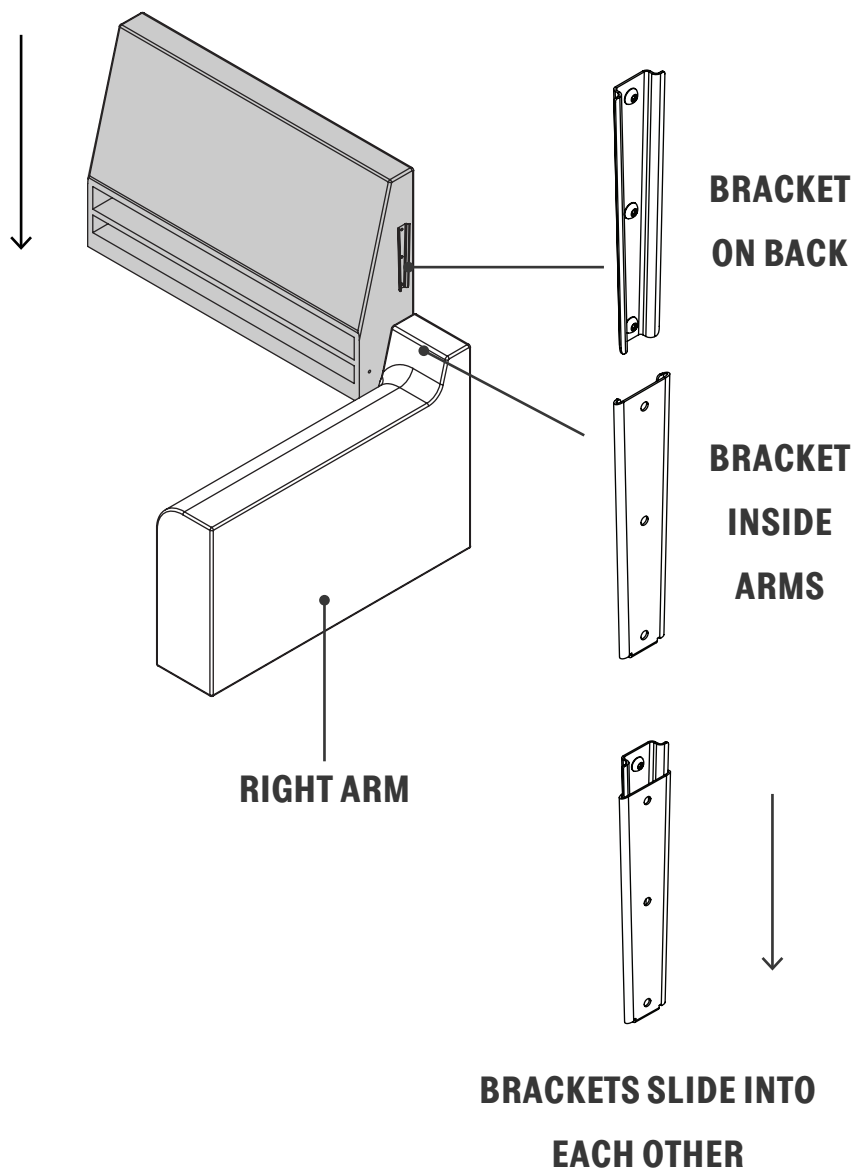

1 Attach Backs to Arms

- B** Take the second Back and align the bracket to the first Back. Slide the second Back down to connect the two Backs.

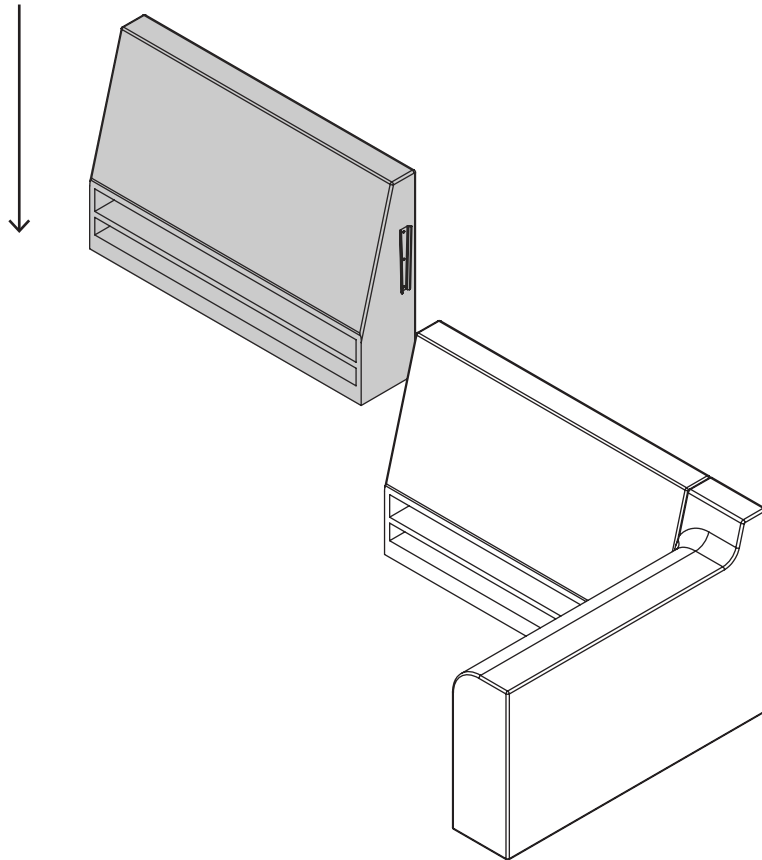

1 Attach Backs to Arms

- C** Take the left Arm and align it to the bracket on the second Back. Slide the arm down until the bottom of both pieces are aligned.

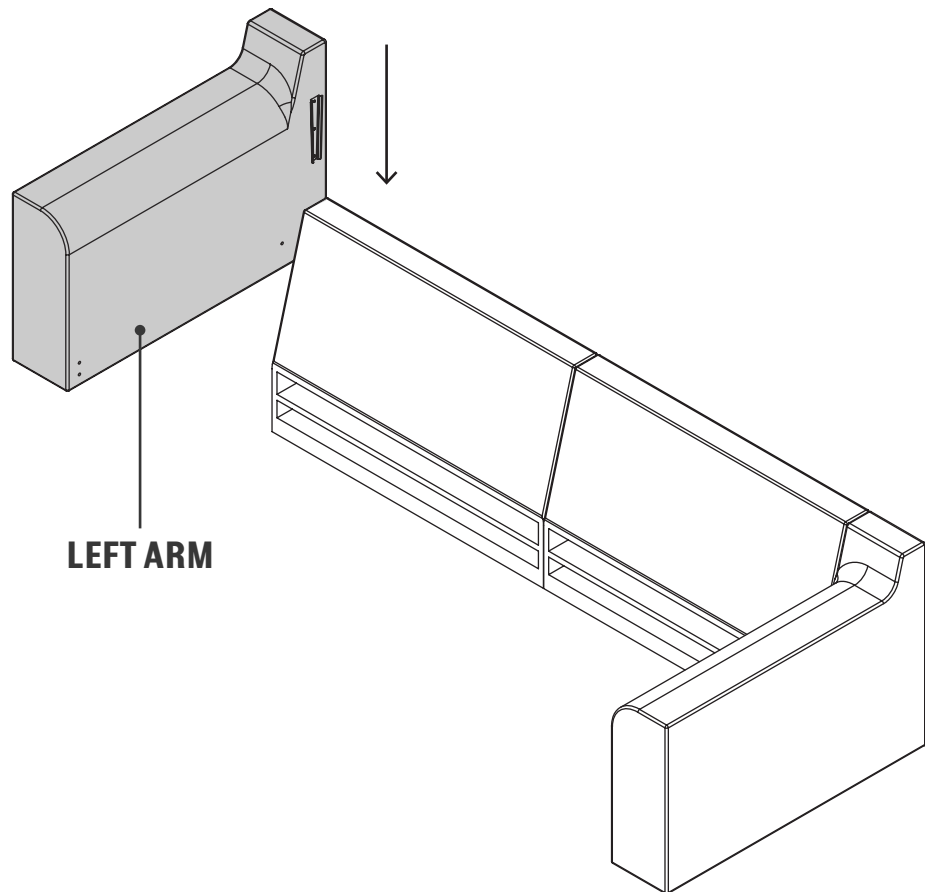

2 Secure Backs to Arms

- A** Take one Bolt and insert it into the hole in the back cavity that lines up with a hole on the Arm. Screw the Bolt in loosely with your fingers.

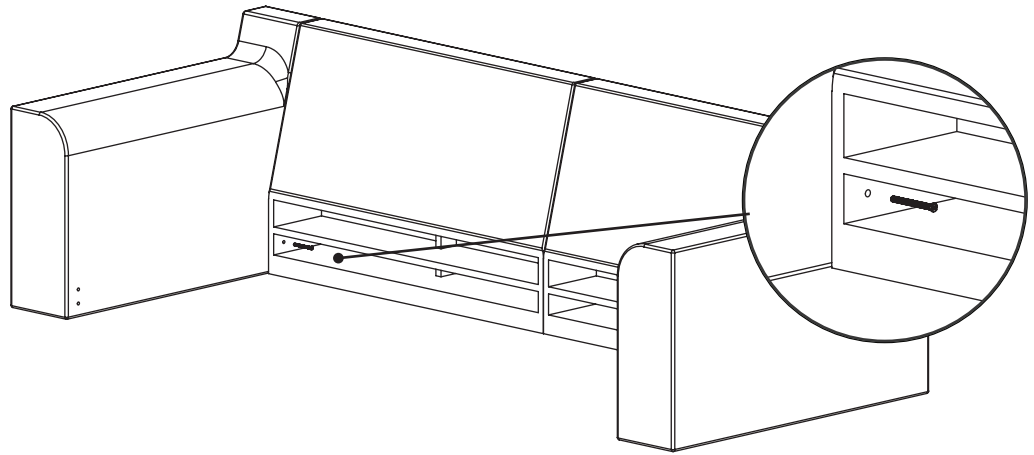

- B** Take a second Bolt and insert it into the hole in the opposite back cavity that aligns with a hole on the Arm. Screw the Bolt in loosely with your fingers.

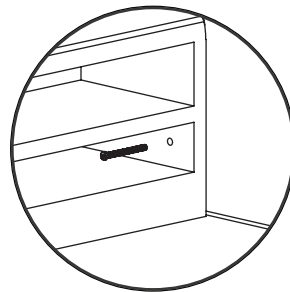

2 Secure Backs to Arms

C Tighten both Bolts firmly in place using the Ratchet Wrench. The Ratchet Wrench allows you to tighten the Bolt without having to remove the wrench from the bolt each time you have reached the limit of how far it can go in that direction. Instead, you can simply go back in the opposite direction without moving the bolt and continue tightening. The same applies when you are loosening a bolt.

Make sure the switch on the side is flipped down when tightening, and up when loosening.

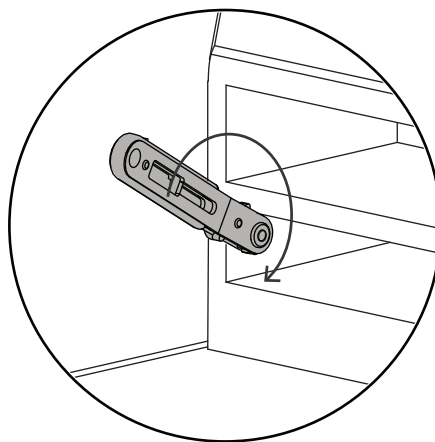

+ REPEAT ON OTHER SIDE

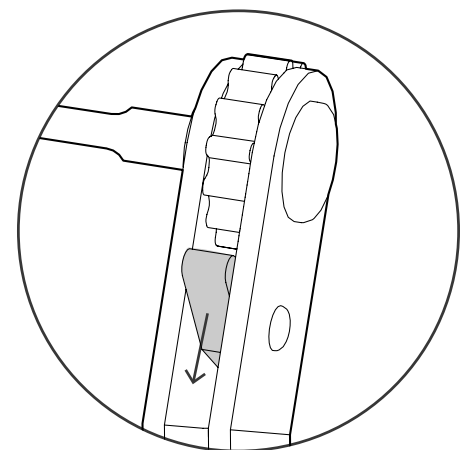

FLIP DOWN = TIGHTEN

FLIP UP = LOOSEN

3 Secure Front Rail

A Line the Front Rail up between the two Arms.

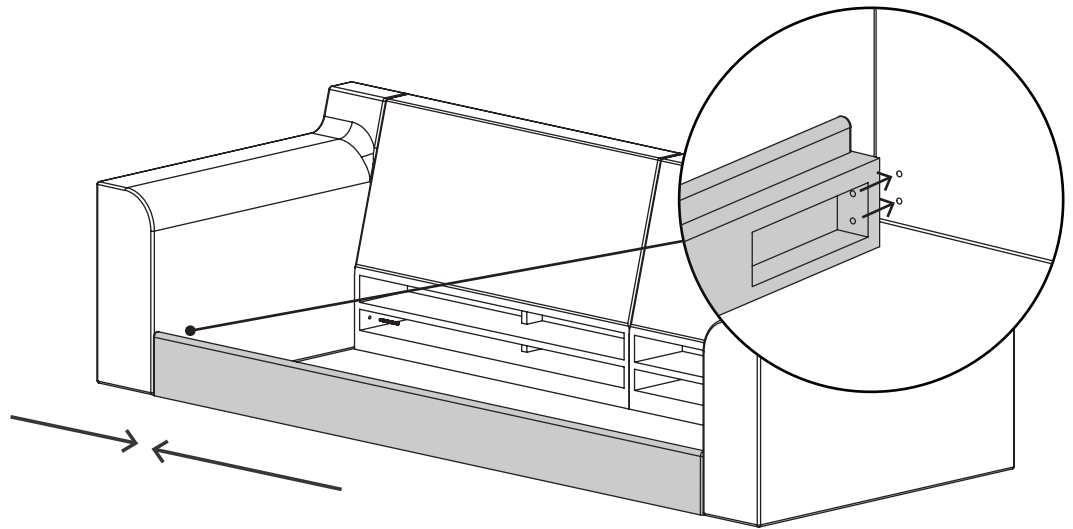

B Take two Bolts and insert them into the holes in the Front Rail that lines up with the holes in the Arms. Use the Ratchet Wrench to tighten the bolts firmly in place.

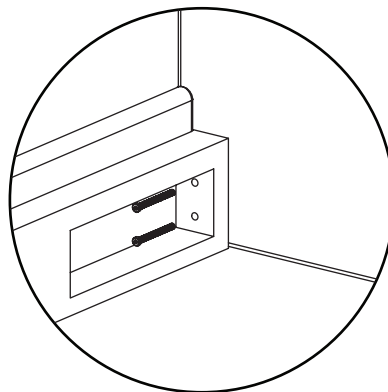

4 Attach Legs

A

Flip the Sofa on its back.

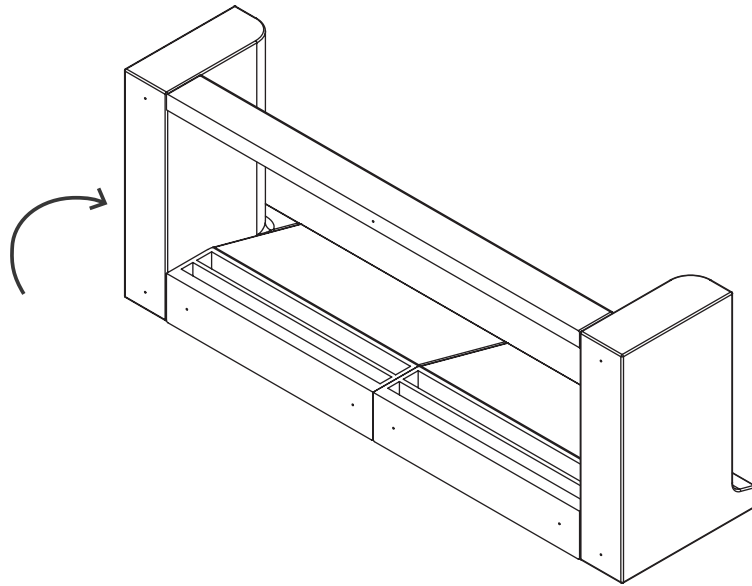
**B**

Insert Bolts through the hole in each Leg. The head of the Bolt will sit within the with the larger drilled hole on the foot once tightened.

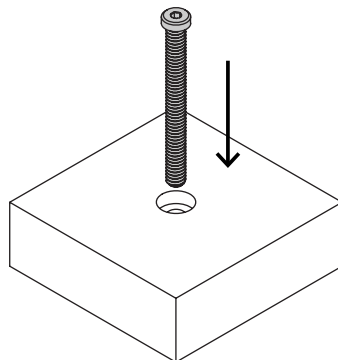

4 Attach Legs

C Align Square Legs to holes on the bottom of the Arms and Backs. Screw in the Legs using the Ratchet Wrench.

The rectangular shaped Center Leg is to be connected at the center of the Front Rail aligning the long edge of the leg parallel to the Front Rail. Screw in the Leg using the Ratchet Wrench.

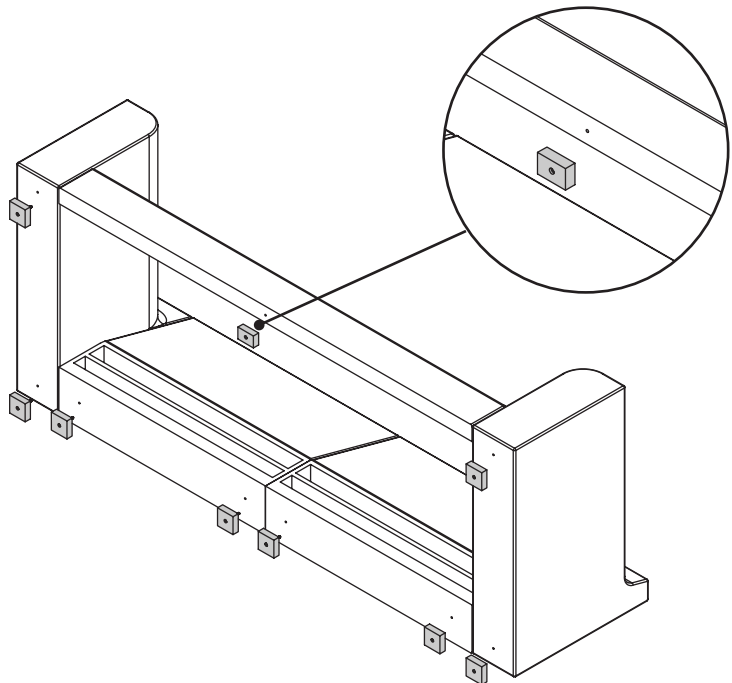

5 Lay Platforms

- A** Flip the Sofa right side up. Lay the Platforms into the lower cavity in the Back and along the Front Rail.

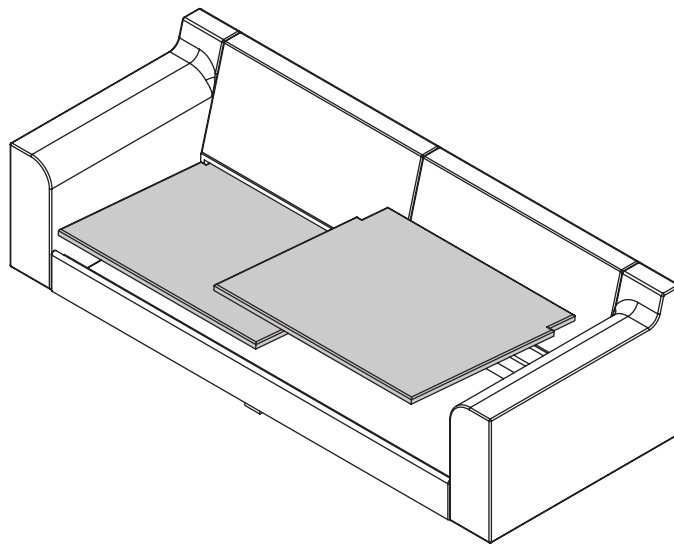

- B** Platforms should lie at an angle, slightly raised in the front to ensure a comfortable seating pitch.

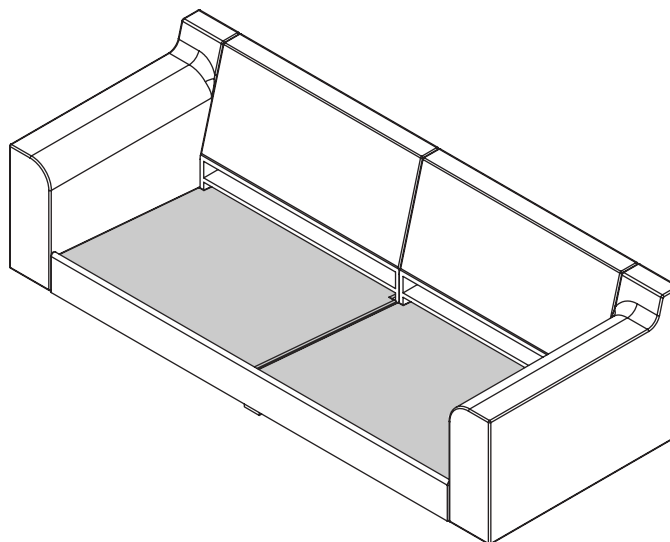

6 Add Cushion & Pillows

A Place the Seat Cushion onto the Sofa.

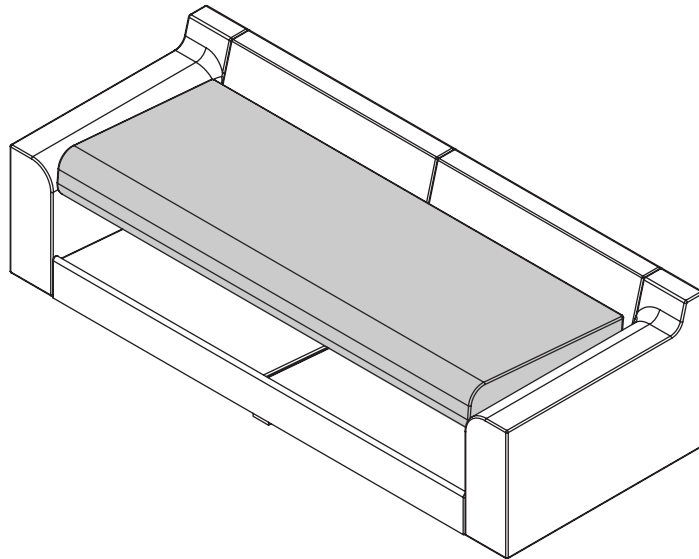

B Place Back Pillows at the back of the Sofa.

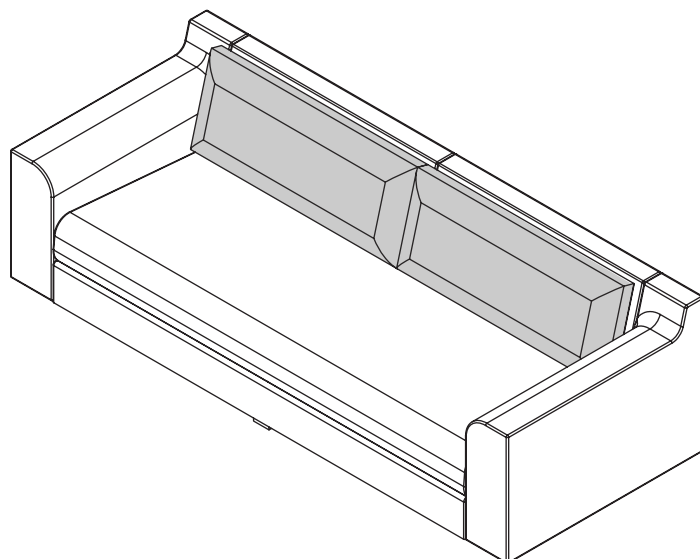

THE ELEVATE SOFA TO BED

Components

THE ELEVATE SOFA

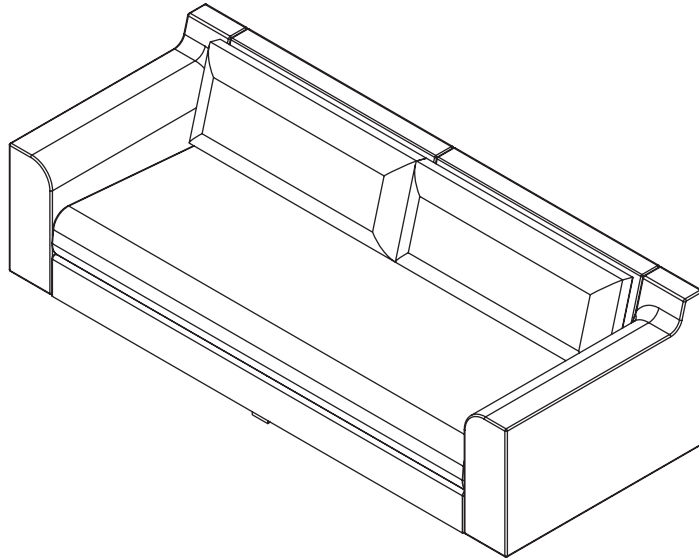

MATTRESS TOPPER

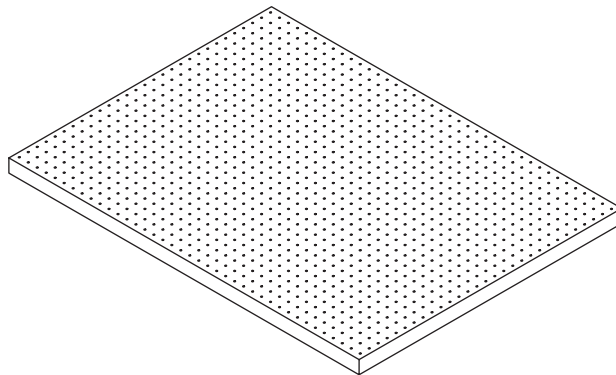

1 Remove Cushions, Pillows, Platforms

- A** Remove the Back Pillows, Seat Cushion, and Platforms from the Sofa.

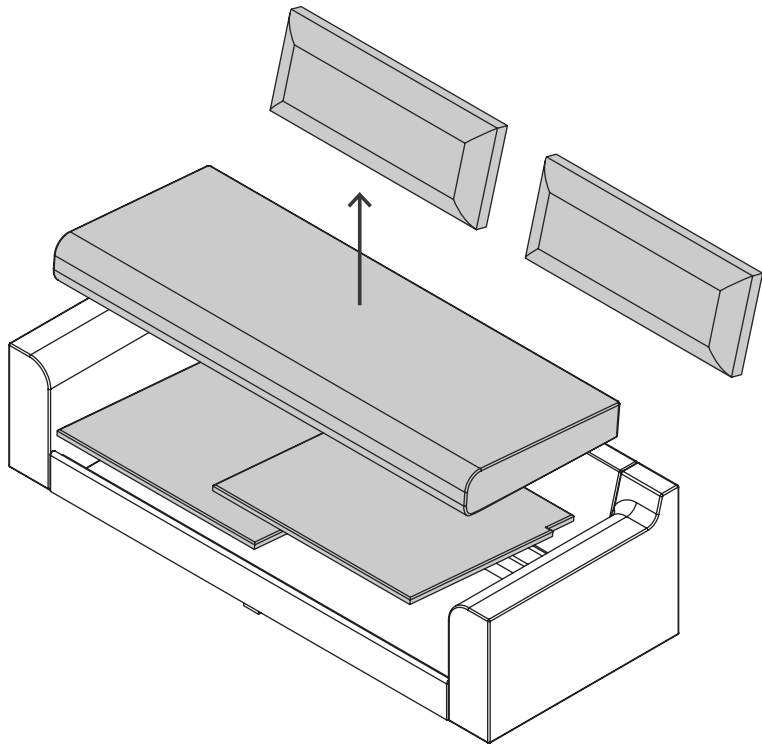

2

Attach Seat Cushion to Front Rail

A

Place the Seat Cushion on the ground in front of the Sofa with the long zipper edge of the Seat Cushion parallel to Front Rail.

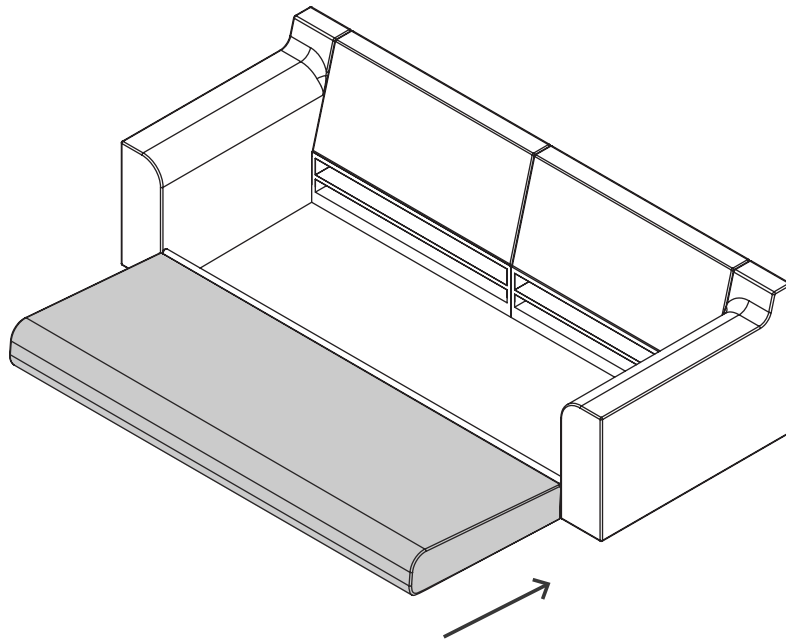

2

Attach Seat Cushion to Front Rail

- B** Attach the velcro fabric flap on the Seat Cushion to the velcro on the inside of the Front Rail in order to secure the Seat Cushion.

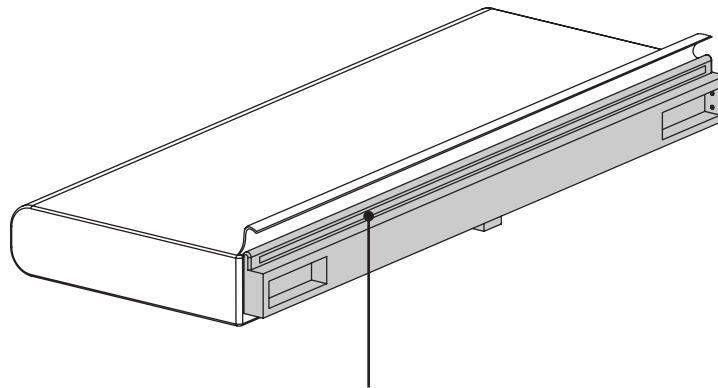

**VELCRO ON INSIDE OF THE
FRONT RAIL**

3 Lay Platforms

- A** Lay the Platforms into the upper cavity in the Back and along the Front Rail.

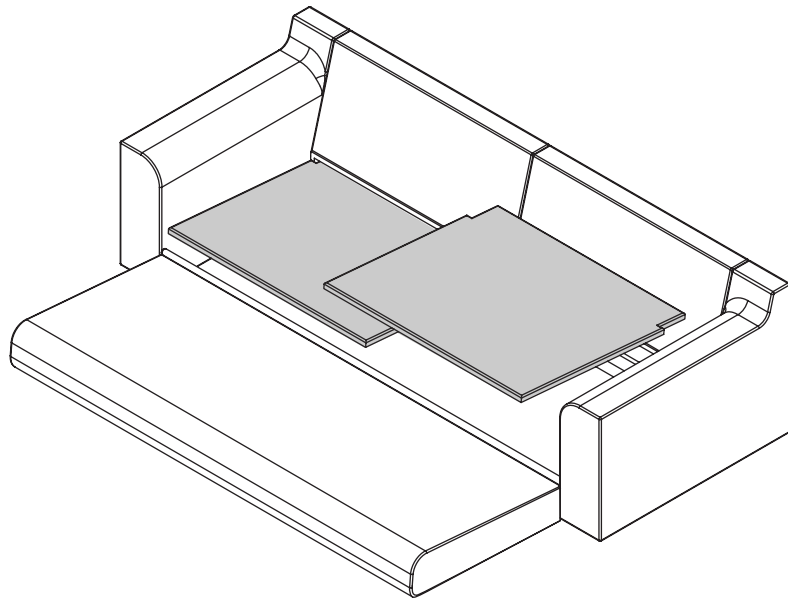

4 Add Mattress Topper

- A** Lay Queen sized Mattress topper across the Seat Cushion and Platforms.

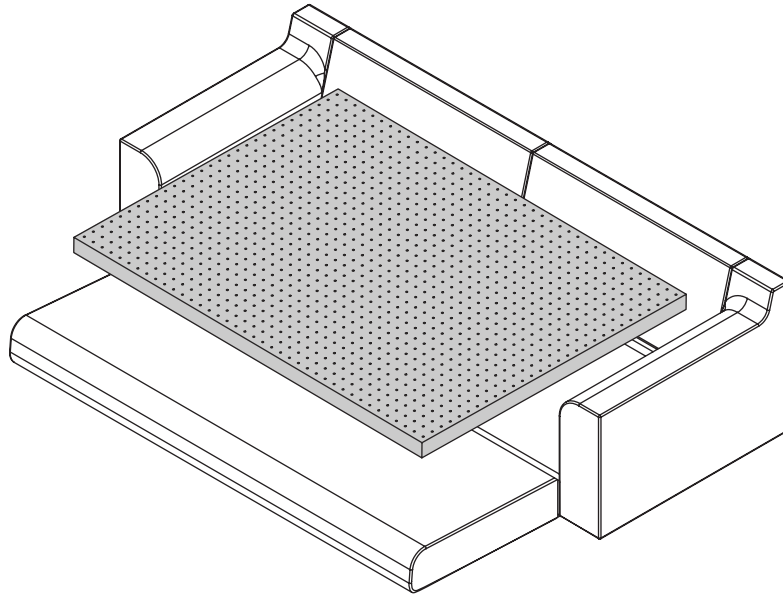

5 Dress the Bed

- A** Cover the Mattress Topper with a flat sheet and dress the bed with your favorite comforter, blankets, and pillows.

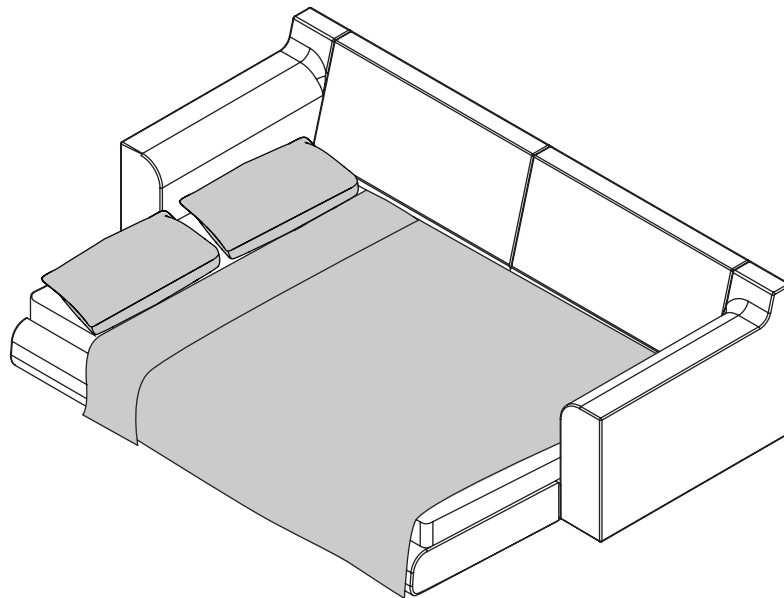

SABAI.DESIGN