

SABAI

Designing the Difference

THE ELEVATE SECTIONAL

Welcome to Sabai

Sabai is designing the difference.

We've minimized your furniture's impact on the environment, from the materials, to the manufacturing process, to programs to extend its life cycle.

Our products are 100% vegan and are made from a combination of recycled, upcycled, and biodegradable materials.

We utilize mechanical fasteners (rather than glue) to ensure that our materials remain recyclable and that we are keeping our manufacturing team safe.

To make sure our furniture stays out of landfills, we've launched two programs under our Sabai Standard: The Repair Don't Replace and Sabai Revive resale programs.

After a simple assembly, you can rest easy with Sabai.

This guide makes assembly a cinch. If you still have questions, you can reach our customer service team at customer@sabai.design and we'll respond within 24 hours.

Components

ARMS
X 2

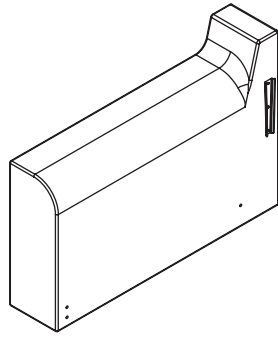

LEFT ARM

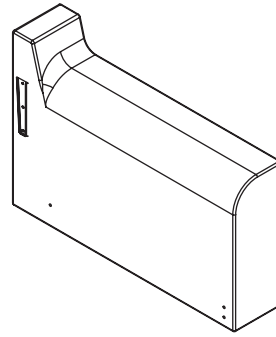

RIGHT ARM

BACKS
X 2

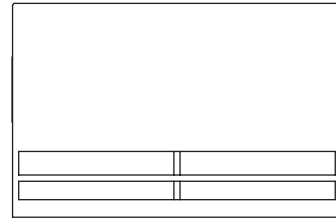
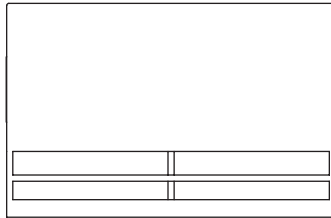

FRONT RAIL

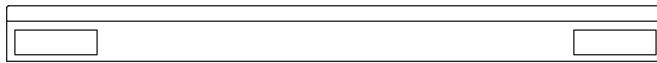

PLATFORMS
X 2



Components

SEAT CUSHION

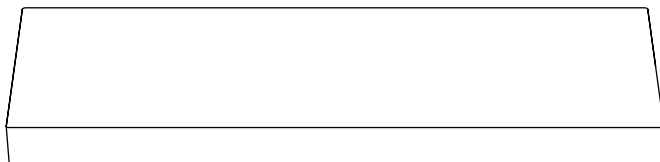

BACK PILLOWS
X 3

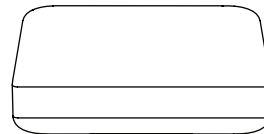
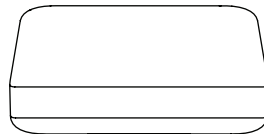
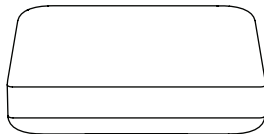

OTTOMAN CUSHION

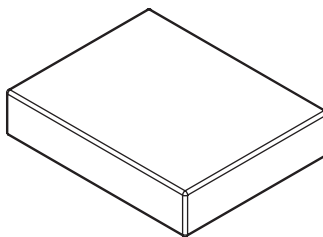

CHAISE CUSHION

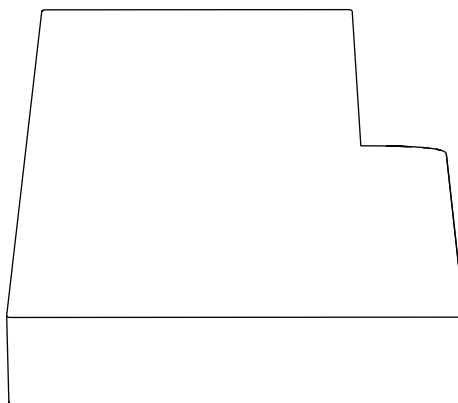

Components

OTTOMAN BASE

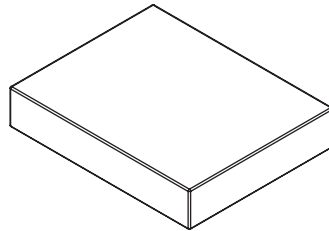

LEGS

- X 12 SQUARE LEG
- X 1 CENTER LEG

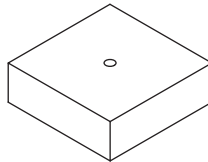

SQUARE LEG

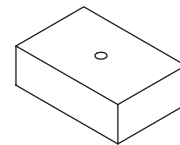

CENTER LEG

OTTOMAN CONNECTORS

- X1 FABRIC STRAP
- X1 METAL LEG TO LEG

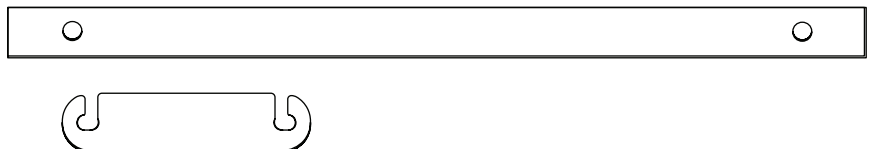

RATCHET WRENCH

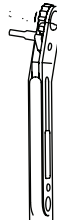

METAL BOLTS

- X 19

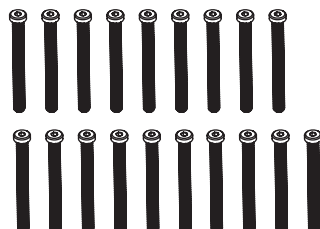

Note: The listed bolt quantity reflects how many bolts are needed for assembly, but you have been provided with extra bolts just in case they're needed.

1 Attach Backs to Arms

- A** Take one Back and the Right Arm and align the brackets on both pieces. Slide the Back down to line up with the bottom of the Right Arm.

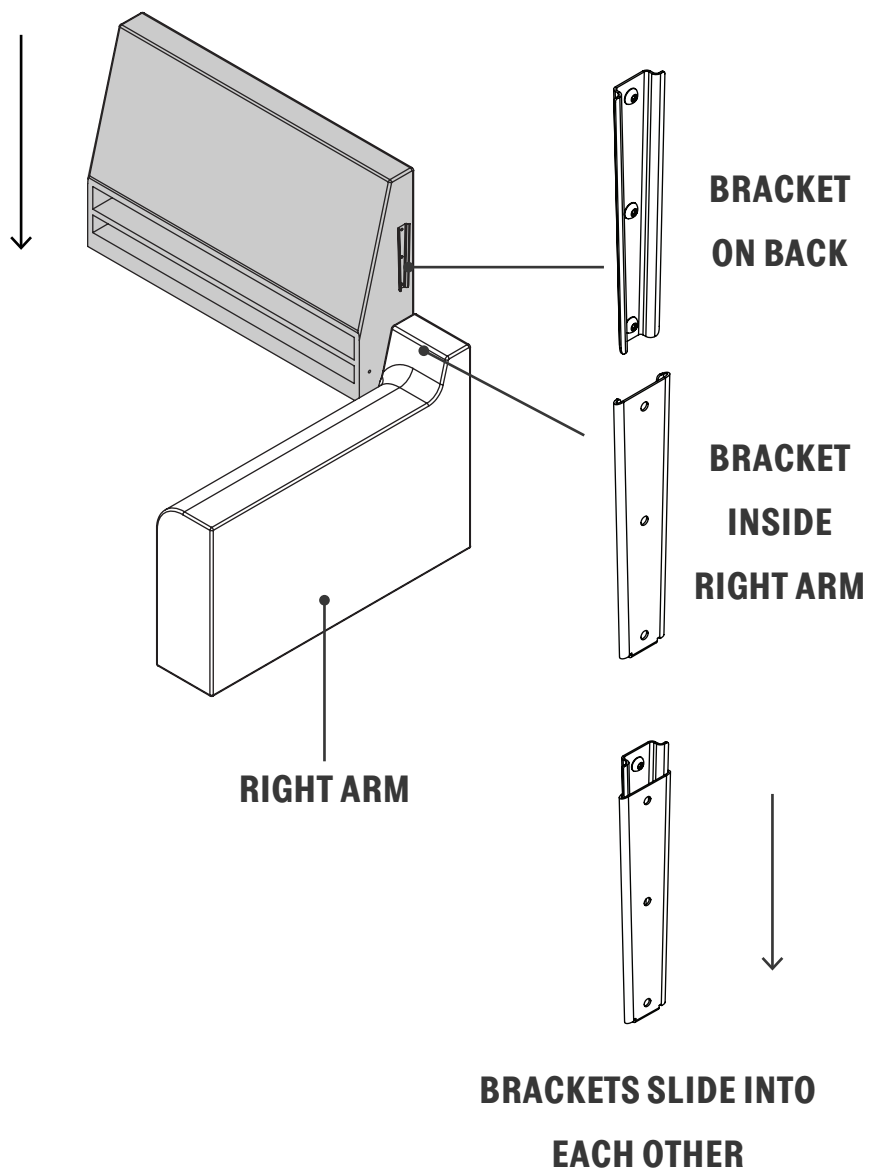

1 Attach Backs to Arms

- B** Take the second Back and align the bracket to the first Back piece. Slide the second Back down to connect the two Backs.

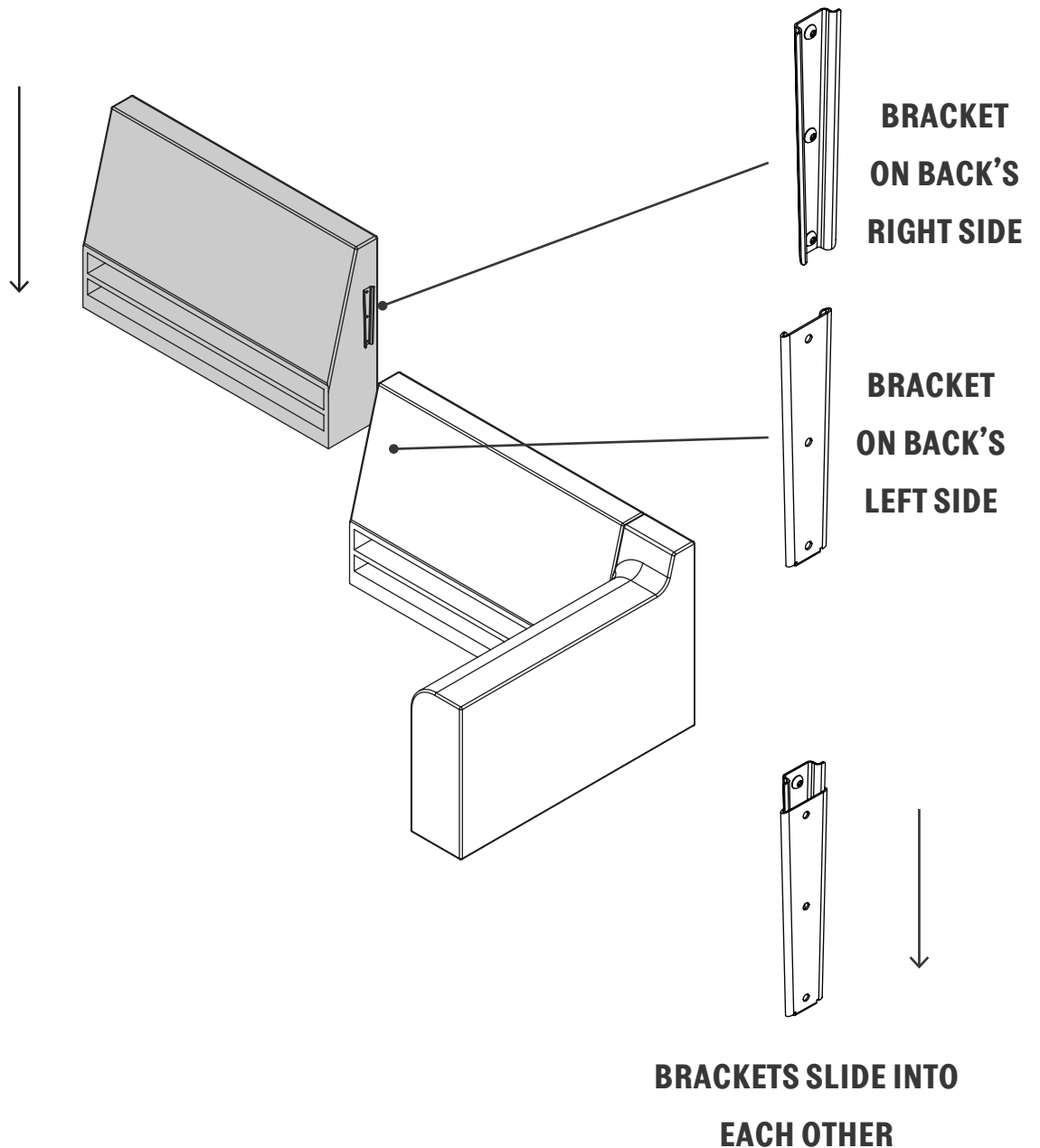

1 Attach Backs to Arms

- C** Take the Left Arm and align it to the bracket on the second Back. Slide the Arm down until the bottom of both pieces are aligned.

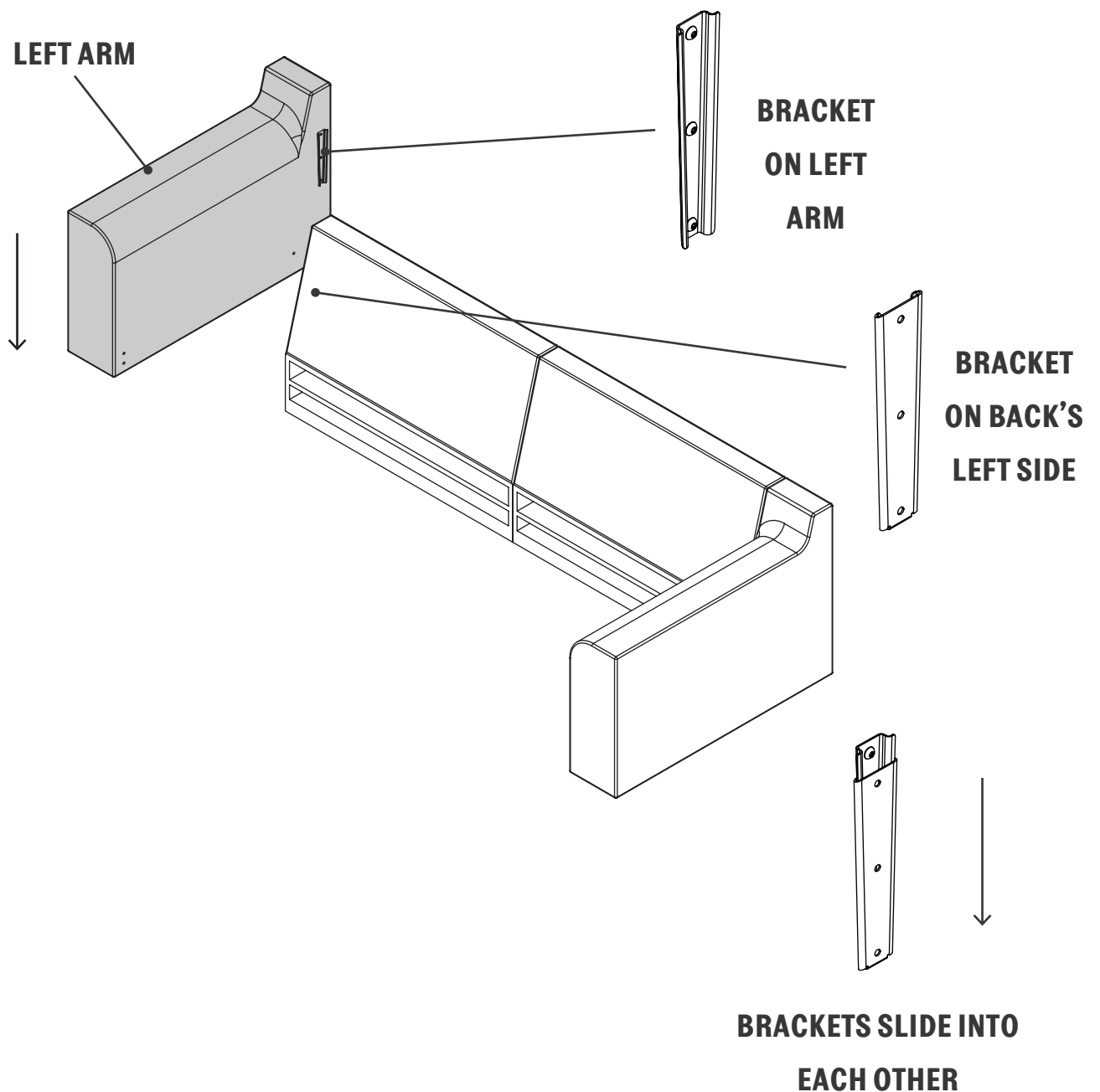

2 Secure Backs to Arms

A

Take one Bolt and insert it into the hole in the back cavity that lines up with a hole on the Arm. Screw the Bolt in loosely with your fingers.

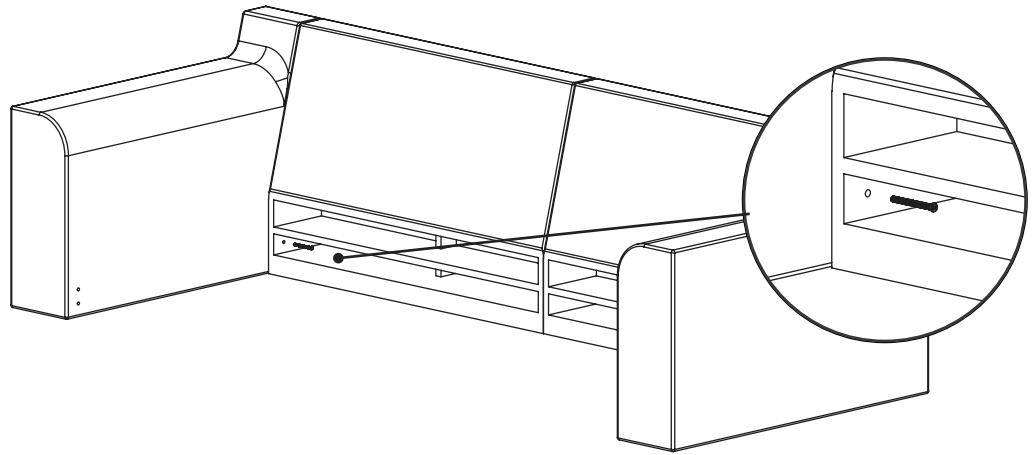
**B**

Take a second Bolt and insert it into the hole in the opposite back cavity that aligns with a hole on the Arm. Screw the Bolt in loosely with your fingers.

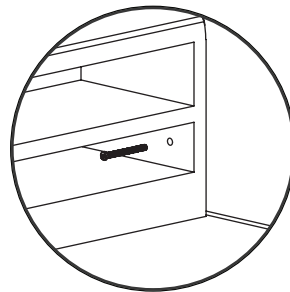

2 Secure Backs to Arms

- C** Tighten both Bolts firmly in place using the Ratchet Wrench. The Ratchet Wrench allows you to tighten the Bolt without having to remove the wrench from the bolt each time you have reached the limit of how far it can go in that direction. Instead, you can simply go back in the opposite direction without moving the bolt and continue tightening. The same applies when you are loosening a bolt.

Make sure the switch on the side is flipped down when tightening, and up when loosening.

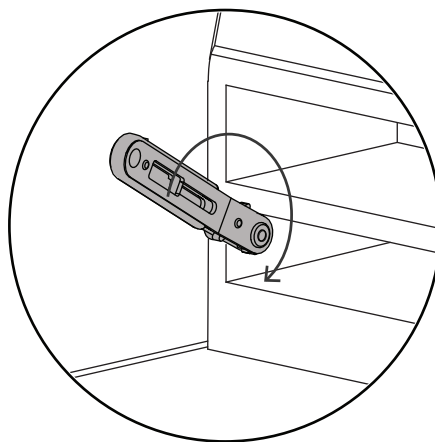

+ REPEAT ON OTHER SIDE

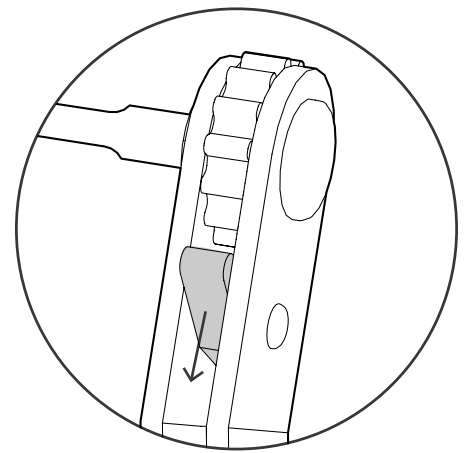

FLIP DOWN = TIGHTEN

FLIP UP = LOOSEN

3 Secure Front Rail

A Line the Front Rail up between the two Arms.

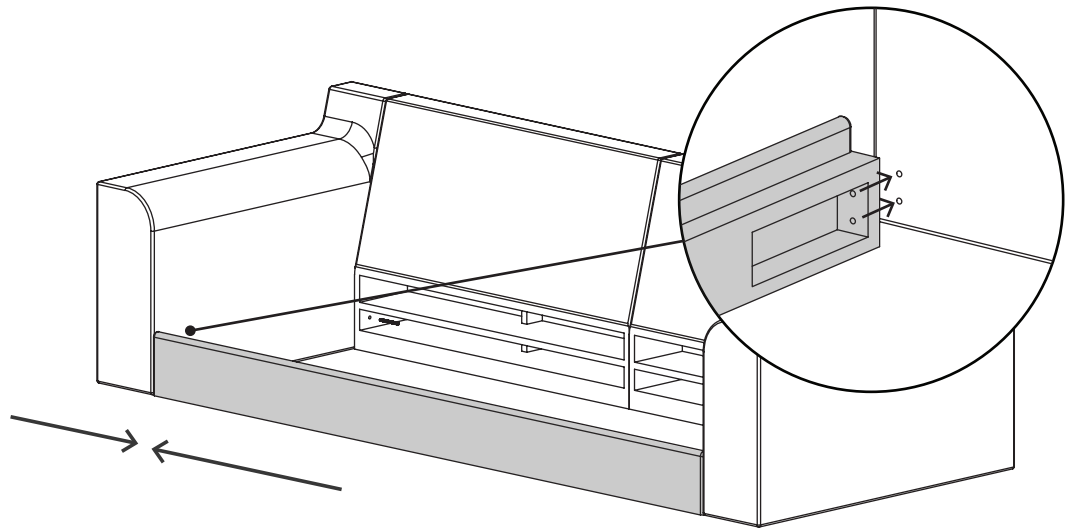

B Take two Bolts and insert them into the holes in the Front Rail that lines up with the holes in the Arms. Use the Ratchet Wrench to tighten the bolts firmly in place.

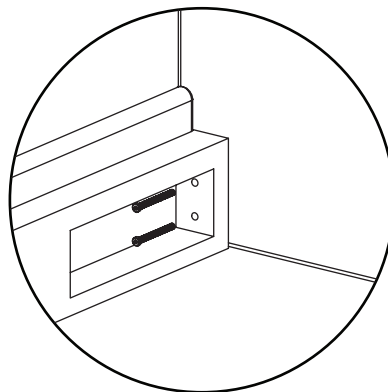

4 Attach Legs

A

Flip the Sofa on its back.

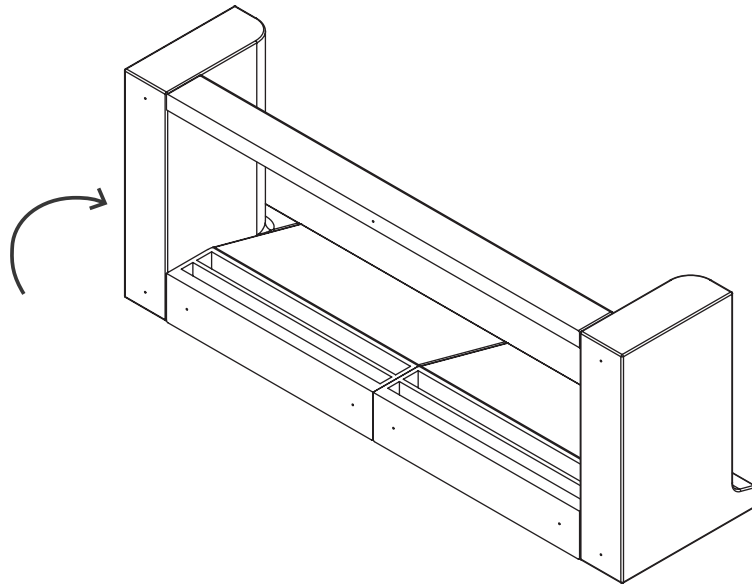
**B**

Insert Bolts through the hole in each Leg. The head of the Bolt will sit within the with the larger drilled hole on the foot once tightened.

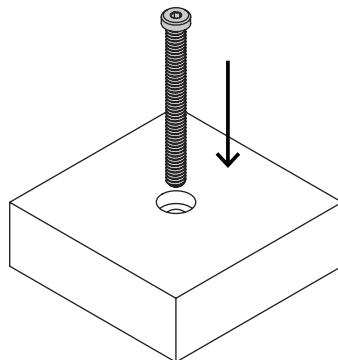

4 Attach Legs

C Align Square Legs to holes on the bottom of the Arms and Backs. Screw in the Legs using the Ratchet Wrench.

The rectangular shaped Center Leg is to be connected at the center of the Front Rail aligning the long edge of the leg parallel to the Front Rail. Screw in the Leg using the Ratchet Wrench.

Determine if you want your Chaise Cushion to be on the left or right side. Loosen the leg on the front Arm on the side the Chaise will go in order to leave room for the Metal Connector.

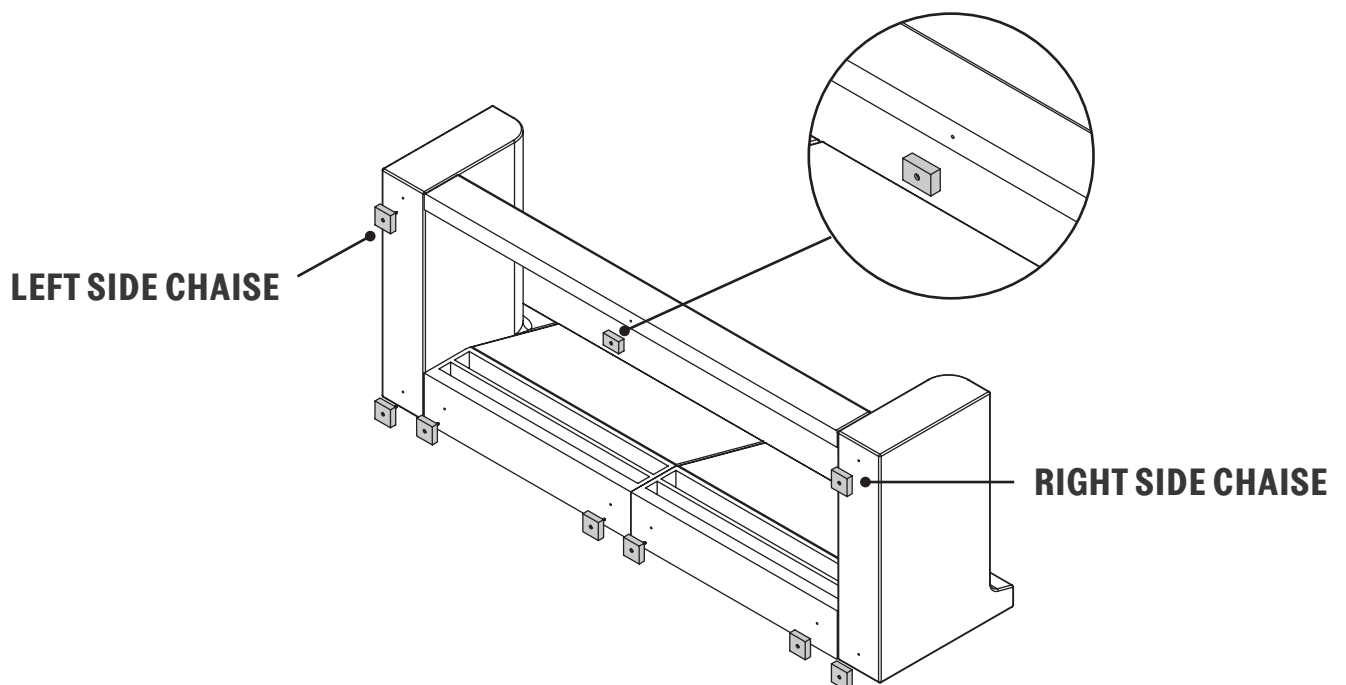

5 Lay Platforms

- A** Flip the Sofa right side up. Lay the Platforms into the lower cavity in the Back and along the Front Rail.

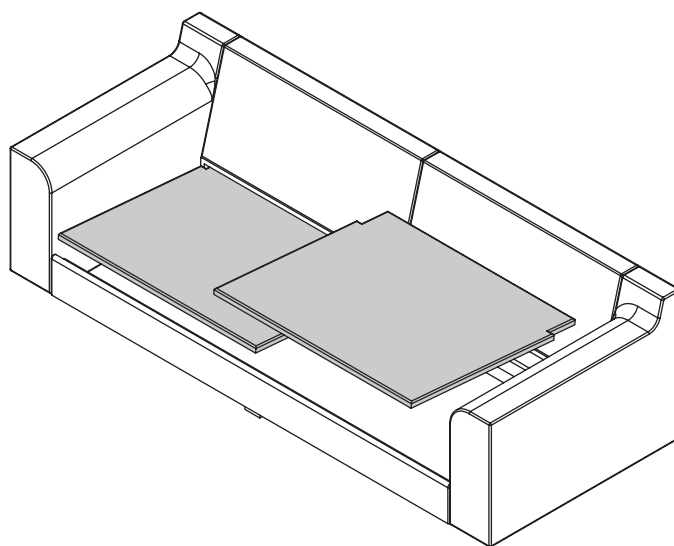

- B** Platforms should lie at an angle, slightly raised in the front to ensure a comfortable seating pitch.

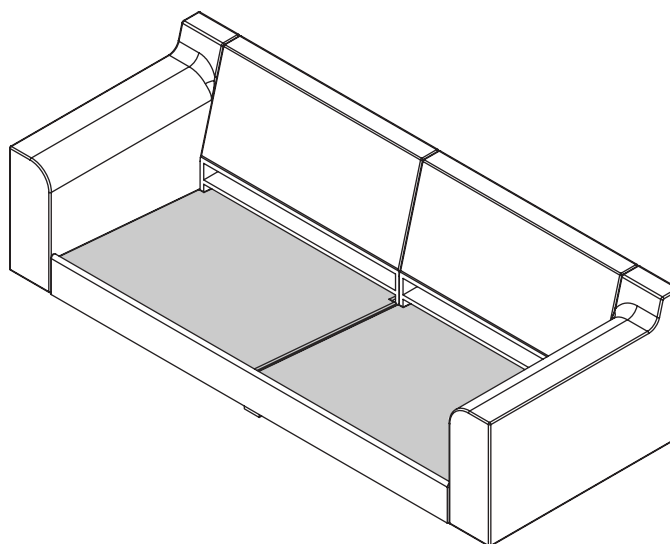

6 Prepare Ottoman

A Flip the Ottoman upside down and attach the Legs with the Ratchet Wrench.

Locate the two legs on the side that will touch the Front Rail. Loosen both legs to leave room for the Metal and Fabric Connector in the following steps.

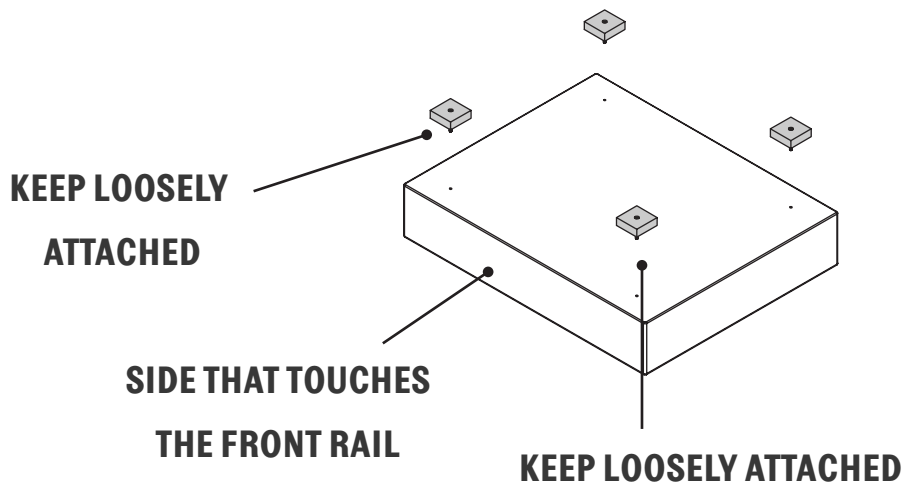

6 Prepare Ottoman

B Flip the Ottoman right side up and align it with the Arm you want to have the Chaise located.

The longer side of the Ottoman should run parallel to the Sofa and the end on the Ottoman should line up with the outer edge of the Arm.

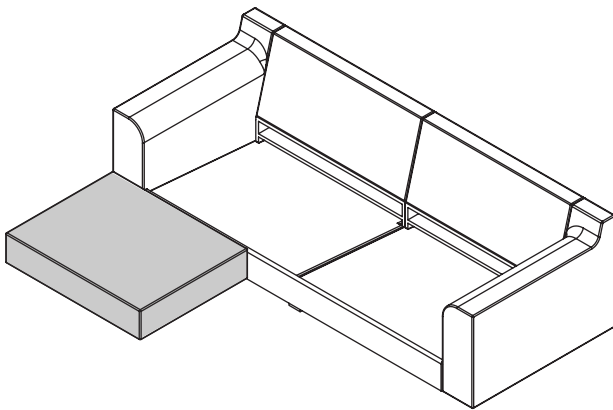

LEFT SIDE CHAISE

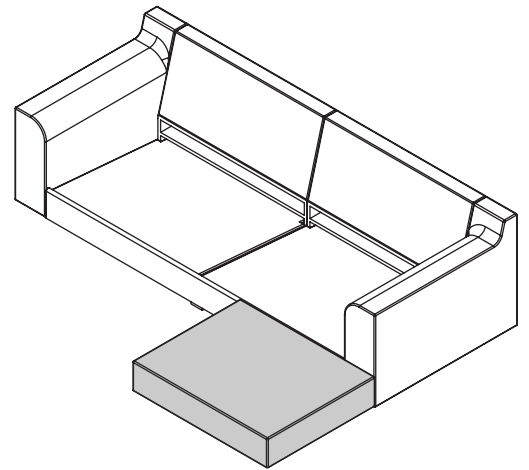

RIGHT SIDE CHAISE

7

Attach Fabric Connector

A

The Fabric Connector will attach the inside Leg of the Ottoman to the Front Rail. Wrap the Fabric Connector around the Front Rail, going from the bottom and coming around the top. The two ends should meet at the inside leg of the Ottoman.

Loosen the inside Leg completely and insert the bolt through the two holes on the Fabric Connector.

Tighten the Leg onto the Ottoman to secure the Fabric Connector

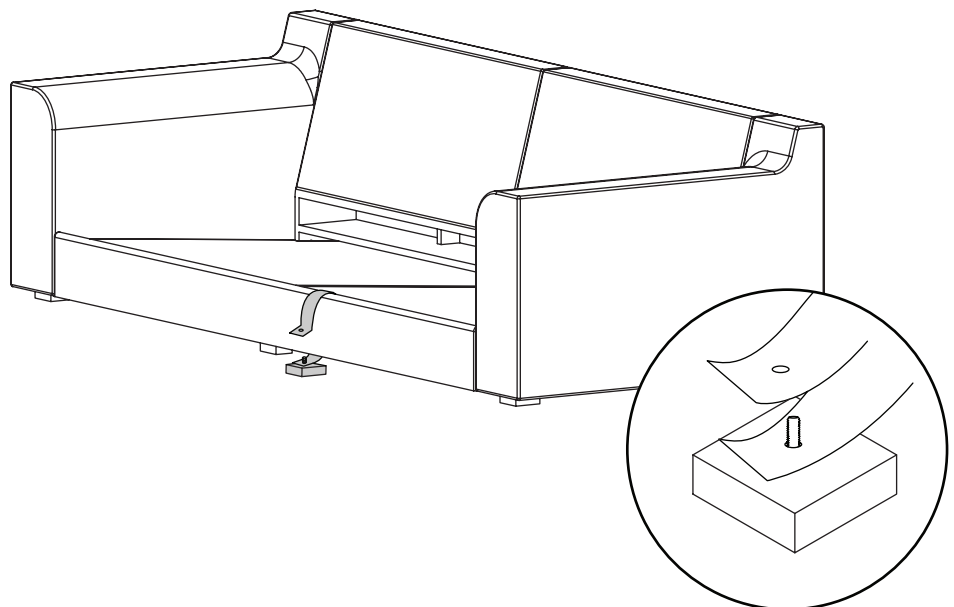

8

Attach Metal Connector

A

The Metal Connector is used to connect the outside Leg of the Ottoman to the Leg on the Arm. Unscrew both Legs.

Slide the Metal Connector around both of the Legs' bolts and then tighten both legs to secure the Ottoman to the Arm.

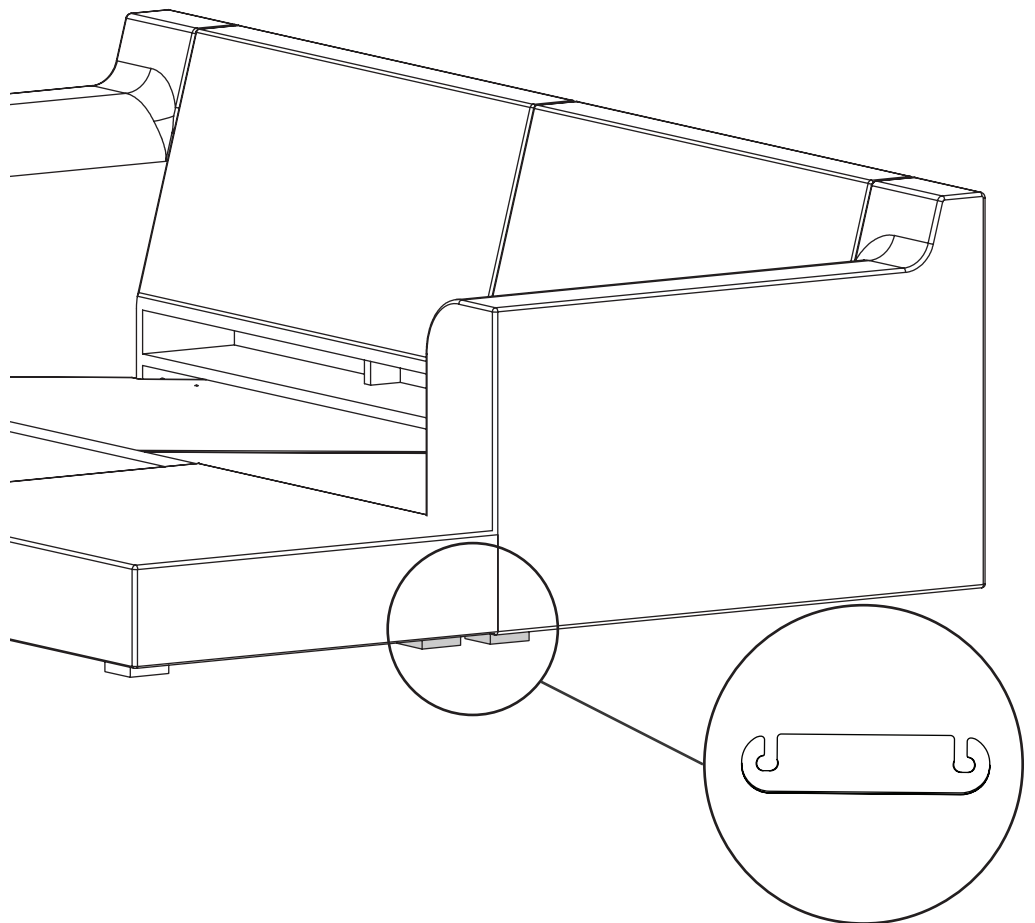

9 Add Cushions

- A** Place the Cushion onto the Sofa, running from the side without an Ottoman to the middle.

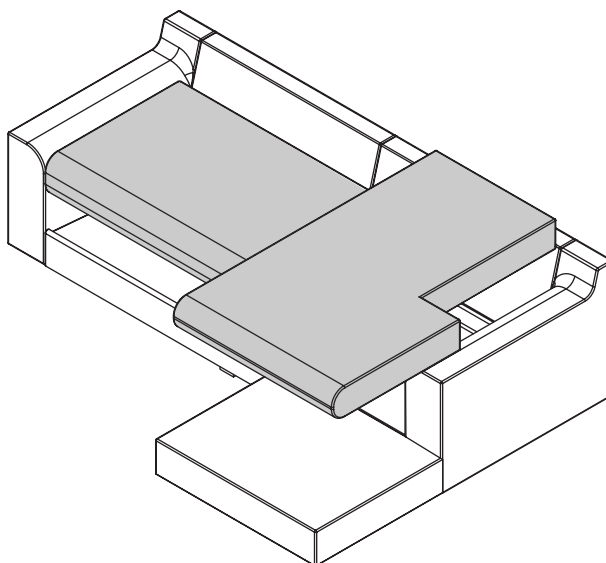

- B** Place the Chaise Cushion across the Sofa and Ottoman. The notch of the cushion should wrap the Arm.

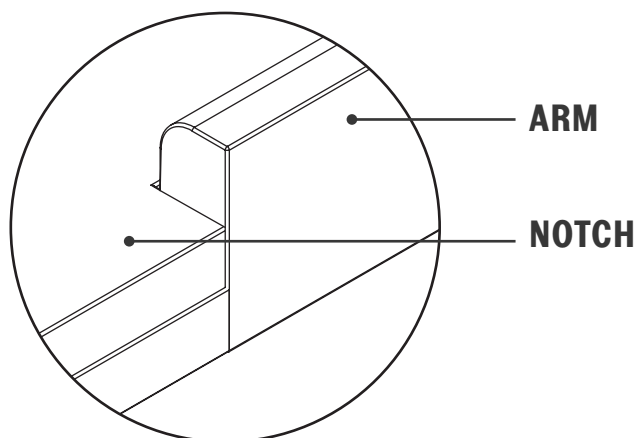

10

Add Back Pillows

A Place the Back Pillows at the back of the Sectional.

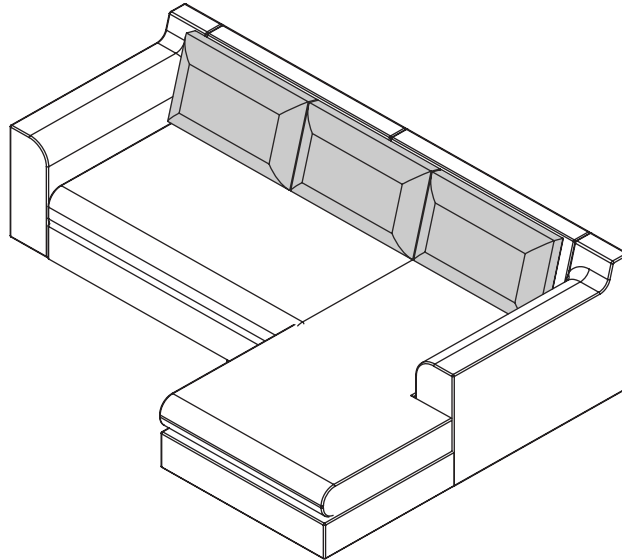

SABAI.DESIGN